

FyreBOX Cast-In

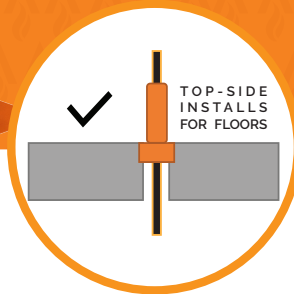

The FyreBOX Cast-In is a simple multi-service passive fire penetration system that can be cast directly into the floor slabs of a building that will prevent the spread of fire through service penetrations whilst reducing the footprint needed for riser shafts and cupboards.

The FyreBOX Range has been tested to AS1530.4-2014 for a range of mixed services and is one of the most fire tested products in the world with industry leading FRL's of up to -/240/240 (system specific).



**BIM MODELS
NOW AVAILABLE**
CLICK HERE

Click to Watch
Installation Video



KEY FEATURES

- Cast into slab to save time in construction
- Allows multiple and mixed services to pass through one opening
- Mixed services approved in any quantity or configuration
- Space saving, eliminates the need for 200mm separation between adjacent services
- Tested in various slab thickness
- Fire tested in independent laboratories
- Thoroughly tested to AS1530.4-2014

APPLICATIONS

Electricians	Power Data cables Conduits
Plumbers	Steel and Copper pipes PVC pipes PEX pipes PEX-AL-PEX pipes
HVAC&R	Insulated pipes Pair Coil
Active Fire	Sprinkler pipes Fire cables

TRADES

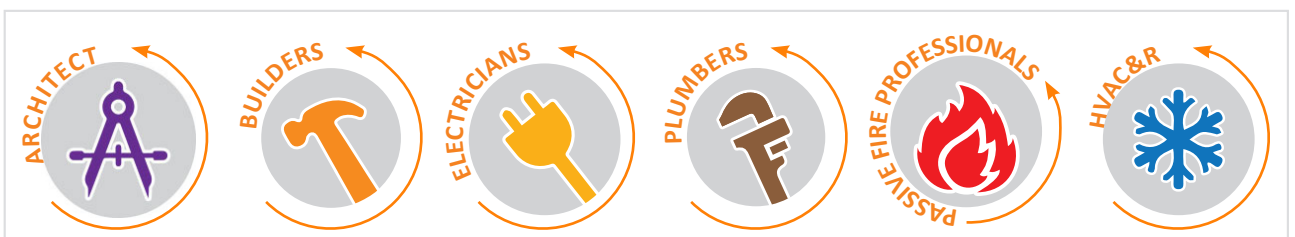

TABLE OF CONTENTS



Section		Page
Benefits		3
System Selector		4
Fire Resistance Level		5
FRL Tables	Concrete Floors 90 min	6
	Concrete Floors 2 Hours	7
	Concrete Floors 3-4 Hours	8
Installation Manual	Concrete Floor Slabs	9-10
	FyreSET® Mortar	11
System Range		12
Compliance		13
FAQ		14
Technical Drawings	Product Overview	15
	Installation Overview	16
	Concrete Slabs	17
	Bondek Slabs	18
	TWRAP™ - Fire Rated Floors	19
	In Close Proximity - Floors	20
	TWRAP in Large Metal Pipes	21

FyreBOX Cast-In

WHAT IS FyreBOX CAST-IN?

Trafalgar Fire’s FyreBOX Cast-In is an intumescent lined product designed to prevent the spread of fire through service penetrations. Think of FyreBOX Cast-In as a fire rated hole, and as a fire takes hold the intumescent material expands to close off the penetration, forming a tight seal around the services and crushing off plastic pipes and pipe insulation. Intumescent foam plugs are also fitted, giving the FyreBOX superior reliability and acoustic properties, and the ability to allow for adds, moves and changes.

FyreBOX Cast-In is tested for multiple and mixed service types, which removes the need to separate service penetrations. All contractors can run their services through the one penetration.

The proudly Australian Made FyreBOX Cast-In systems come in various stock sizes to suit floor slabs up to 350mm thick and can be ordered in custom sizes to suit any application or slab thickness.

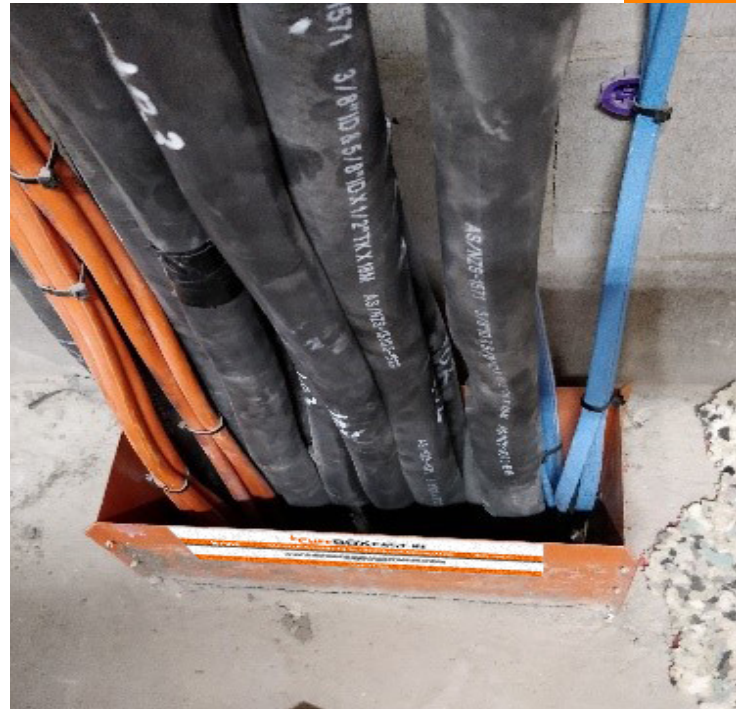

APPLICATIONS

FyreBOX Cast-In systems are suitable for use in any new building where penetrations are required through concrete floors. They have been tested and approved for the following services:

- Electrical, data and communication cables and trays
- Steel and copper pipes
- Insulated copper pipes
- CPVC sprinkler pipes
- PVC conduits
- PVC (Drain, Waste, Vent) pipes
- PEX and Gas PEX-AL-PEX pipes



FyreBOX SYSTEM SELECTOR

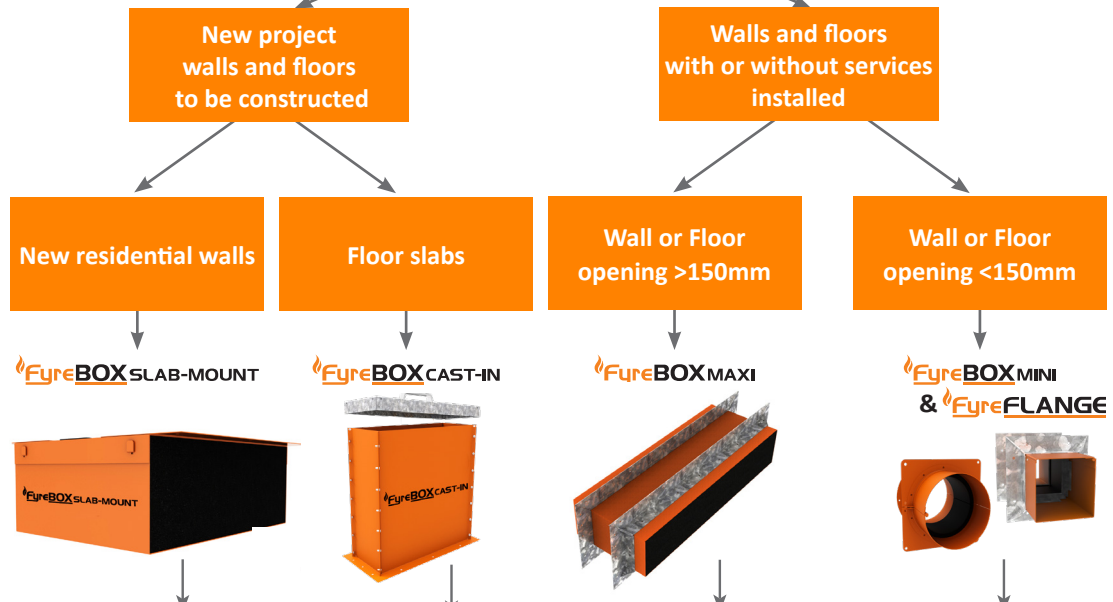

		FyreBOX SLAB-MOUNT	FyreBOX CAST-IN	FyreBOX MAXI	FyreBOX MINI & FyreFLANGE	
Installation Prior to Fire Barrier Construction		✓	✓	✗	✗	
Hole Cutting Required		✗	✗	✓	✓	
Fire Barrier	Floors	Concrete Slab	✗	✓	✓	
		FyreSET® Mortar	✗	✓	✗	✗
	Walls	Masonry Walls	✓	✗	✓	✓
		Concrete Walls	✓	✗	✓	✓
		Plasterboard	✓	✗	✓	✓
		Hebel® / Wasc®	✓	✗	✓	✓
		SpeedPanel®	✓	✗	✓	✓
		Alpha Panel®	✓	✗	✓	✓
		COREX walls	✓	✗	✓	✓
		FyreBOARD Maxilite™	✓	✗	✓	✓
		FyreBATT	✗	✗	✗	✓
		Ceilings	Plasterboard Ceiling	✗	✗	✓
COREX ceilings	✗		✗	✓	✓	
Services	Power Cables	✓	✓	✓	✓	
	Data Cables	✓	✓	✓	✓	
	Cable Trays	✓	✓	✓	✗	
	Steel and Copper Pipes	✓	✓	✓	✓	
	Aluminium Cables	✓	✓	✓	✓	
	CPVC Pipes	✓	✓	✓	✓	
	PVC Pipes	✗	✓	Floors Only	Floors Only	
	PEX	✓	✓	✓	✓	
	PEX-AL-PEX	✓	✓	✓	✓	
	Insulated Copper	✓	✓	✓	✓	
	Pair Coils	✓	✓	✓	✓	

FyreBOX Cast-In

FIRE RATING – HOW IS FIRE PERFORMANCE MEASURED?

An FRL (fire resistance level) is a handy way of summarising the performance of a building element. It consists of 3 numbers, all given in minutes:

FRL 120/120/120

(example)



Structural Adequacy

The ability of the building element to support the weight of adjacent building elements.

ie: a brick wall supporting a concrete floor slab above.



Integrity

The ability of an element to prevent the passage of flames and hot gasses.

ie: a plasterboard wall remaining intact and not allowing holes to form.



Insulation

The ability of an element to resist heat transfer from the exposed face to the unexposed face.

ie: a bundle of cables remaining below a set temperature limit on the unexposed side of the wall penetration system.

Note: Penetrations are not required to have a Structural Adequacy rating and is usually expressed as a dash. For example, a penetration through a 2-hour load bearing wall would be written as -/120/120

INTEGRITY

The FyreBOX Cast-In system will achieve the integrity performance for up to 4 hours physically stopping the direct spread of fire, however the insulation performance of the penetration will be limited to the type of wall being used and conductivity of the services in the penetration.

INSULATION (TEMPERATURE RISE)

Heat transfer via conduction (or heat rise) will occur through the conductive parts of any penetration system. To limit the heat-rise through the FyreBOX Cast-In penetration systems, our 25mm thick TWRAP foil encased blanket can be wrapped around the services and metal casing of the FyreBOX to achieve up to 4 hours of insulation performance. There are some applications that won't require any TWRAP to achieve the full FRL, please refer to the tables below for specific details.

FRL Approvals Tables

Concrete Floors

90 MINUTE FRL SLABS MINIMUM THICKNESS 120MM

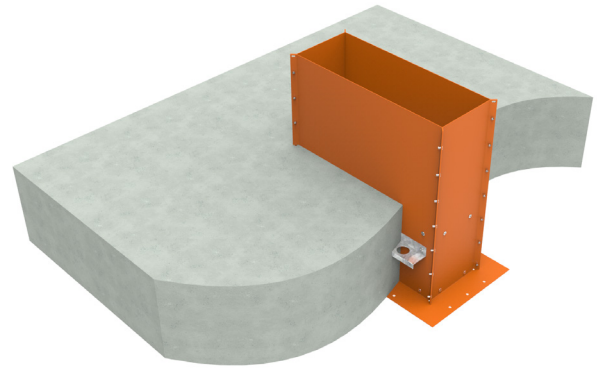

FRL TABLES

Service Type	Service Specification		FRL – Wrap Free	FRL – With TWrap	TWrap Length (mm)
Blank (No Services)	20x20mm Fillet of Fyreflex Sealant applied to perimeter of Fyrebox Cast In (not required when TWrap applied)		-/90/90	Wrap Free	N/a
Plastic Pipes	PEX pipes	up to 32mm OD	-/90/-	-/90/90	450
	PEX-Al-PEX pipes	up to 32mm OD	-/90/-	-/90/90	450
	PVC pipes	up to 80mm OD	-/90/-	-/90/90	300
Bare Metal Pipes	Copper pipes	up to 42mm OD	-/90/-	-/90/90	450
		up to 100mm OD	-/90/-	-/90/90	600 1 st Layer + 450 2 nd Layer [^]
	Steel pipes	up to 50mm OD	-/90/-	-/90/90	450
		up to 100mm OD	-/90/-	-/90/90	600 1 st Layer + 450 2 nd Layer [^]
Metal Pipes Insulated*	Copper pipes	up to 50mm OD with FR insulation	-/90/60	-/90/90	300
	Stainless Steel pipes	Up to 50mm OD with EPS or PE insulation and rockwool	-/90/60	-/90/90	300
	Pair Coils	Up to 9.5 & 19mm with up to 20mm FR insulation (OR 13mm PE) with 10mm OD cable	-/90/60	-/90/90	450
Power Cables- Aluminium Core***	4x Core AL cables	Up to 4 x 240mm ² + optional 90mm ²	-/90/30	-/90/90	300
	Single core AL cables	Up to 1x 400mm ²	N/a	-/90/90	300
Power Cables	TPS cables	Up to 10x per bundle	-/90/60	-/90/90	300
	3x Core cables	19mm diam 3C + E cables	-/90/60	-/90/90	300
	AS1530.4 Appendix D cable set (no cable tray)	Applies to all copper core power cables	-/90/30	-/90/90	450 (190mm + thick floors)
	AS1530.4 Appendix D cable sets on cable trays	Applies to all copper core power cables and cable trays up to 1000mm wide	-/90/30	-/90/90	600 1 st Layer + 300 2 nd Layer [^]
Comms Cables	AS1530.4 Appendix D cable sets on cable trays	Copper core comms cables and cable trays up to 1000mm wide	-/90/60	-/90/90	300
	Fibre Optic cables	NBN grade cable	-/90/30	-/90/90	300
	CAT6	Up to 150x per bundle	-/90/60	-/90/90	300
Conduits	uPVC Conduits Rigid or Flexible	Up to 32mm OD (with or without cables)	-/90/60	-/90/90	300

[^]Large metal pipes require 2 layers of TWrap. Refer to page [page 21](#)

*With or without heat trace cable

***With 300mm of loose TWrap infill (foil removed) packed around the services within the wrap if cable tray is used

***Aluminium cable bundles spaced 50mm apart when installed on cable tray

FRL Approvals Tables

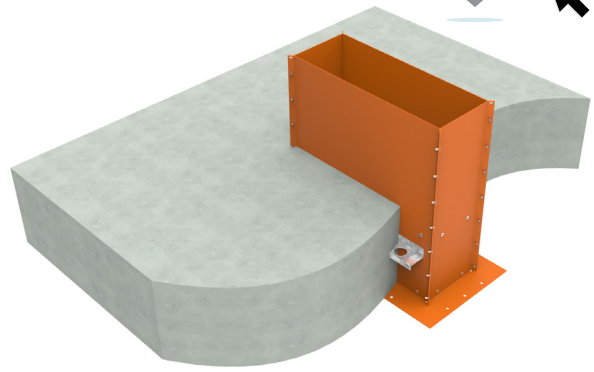

Concrete Floors

2 HOUR FRL SLABS MINIMUM THICKNESS 120MM

Service Type	Service Specification		FRL – Wrap Free	FRL – With TWrap	TWrap Length (mm)
Blank (No Services)	20x20mm Fillet of Fyreflex Sealant applied to perimeter of Fyrebox Cast In (not required when TWrap applied)		-/120/120	Wrap Free	N/a
Plastic Pipes	PEX pipes	up to 32mm OD	-/120/-	-/120/120	450
	PEX-Al-PEX pipes	up to 32mm OD	-/120/-	-/120/120	450
	PVC pipes	up to 80mm OD	-/120/-	-/120/120	300
Bare Metal Pipes	Copper pipes	up to 42mm OD	-/120/-	-/120/120	450
		up to 100mm OD	-/120/-	-/120/120	600 1 st Layer + 450 2 nd Layer [^]
	Steel pipes	up to 50mm OD	-/120/-	-/120/120	450
		up to 100mm OD	-/120/-	-/120/120	600 1 st Layer + 450 2 nd Layer [^]
Metal Pipes Insulated*	Copper pipes	up to 50mm OD with FR insulation	-/120/60	-/120/120	300
	Stainless Steel pipes	Up to 50mm OD with EPS or PE insulation and rockwool	-/120/60	-/120/120	300
	Pair Coils	Up to 9.5 & 19mm with up to 20mm FR insulation (OR 13mm PE) with 10mm OD cable	-/120/60	-/120/120	450
Power Cables- Aluminium Core***	4x Core AL cables	Up to 4 x 240mm ² + optional 90mm ²	-/90/30	-/120/120	300
	Single core AL cables	Up to 1x 400mm ²	N/a	-/120/120	300
Power Cables	TPS cables	Up to 10x per bundle	-/120/60	-/120/120	300
	3x Core cables	19mm diam 3C + E cables	-/120/60	-/120/120	300
	AS1530.4 Appendix D cable set (no cable tray)	Applies to all copper core power cables	-/120/30	-/120/120	600 (min. 190mm slab)
	AS1530.4 Appendix D cable sets on cable trays	Applies to all copper core power cables and cable trays up to 1000mm wide	-/120/30	-/120/120	600 1 st Layer + 300 2 nd Layer [^]
Comms Cables	AS1530.4 Appendix D cable sets on cable trays	Copper core comms cables and cable trays up to 1000mm wide	-/120/60	-/120/120	450 (Min.190mm slab) Or 600mm**
	Fibre Optic cables	NBN grade cable	-/120/30	-/120/120	300
	CAT6	Up to 150x per bundle	-/120/60	-/120/120	300
Conduits	uPVC Conduits Rigid or Flexible	Up to 32mm OD (with or without cables)	-/120/60	-/120/120	300

[^]Large metal pipes require 2 layers of TWrap. Refer to [page 21](#)

*With or without heat trace cable

**With 300mm of loose TWrap infill (foil removed) packed around the services within the wrap if cable tray is used

***Aluminium cable bundles spaced 50mm apart when installed on cable tray

FRL TABLES

FRL Approvals Tables

Concrete Floors

3-4 HOUR FRL SLABS MINIMUM THICKNESS 175MM

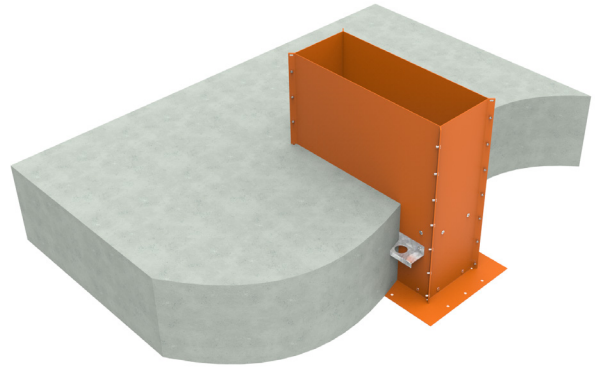

FRL TABLES

Service Type	Service Specification		FRL – Wrap Free	FRL – With TWrap	TWrap Length (mm)
Metal Pipes	Steel Pipes	Up to 50mm	-/120/-	-/240/120	450
Insulated Metal Pipes	Stainless Steel Pipes	Up to 50mm OD with EPS or PE insulation and rockwool	-/240/60	-/240/240	300
Power Cables	3x Core	Up to 2x 19mm 3C + E per bundle	-/240/60	-/240/120	300
Comms Cables	CAT6	Up to 5x per bundle	-/240/60	-/240/120	300
Power Cables- Aluminium Core	Single core AL cables	Up to 1x 400mm ²	N/a	-/180/180*	300

*Contract Trafalgar before use.

THE CHALLENGE WITH 3-4 HOUR FRL'S

After two hours of the AS1530.4 fire test, the temperatures inside the furnace will increase from 1050 to 1200 degree's C which is above the melting points of some metals like copper. Therefore, most copper based building services (cables and copper pipes) are practically very difficult to remain under the insulation (heat rise) criteria past 2 hours.

In this case, please refer to our specific **3-4 hour FRL Applications Manual** for specific advice on how fire engineering can deal with these penetrations as an alternate solution to address the building code's performance requirements.



FyreBOX Cast-In after a 4 hour test.

Click Here

[Download 3-4 Hour Penetrations Applications Manual](#)

INSTALLATION

CONCRETE FLOOR SLABS

POSITION



Position the FyreBOX Cast-In in the desired penetration position and then nail/screw to the timber formwork through the flanges.

POUR SLAB



Ensure the galvanized steel lid is on the FyreBOX, and pour the concrete to the specified depth and allow to cure.

Steel lid is provided for added safety, so tools and materials can't be dropped from one floor of a building to another. Lids can be disposed after use.

PREPARE



After the concrete has cured, remove the timber formwork from the other side of the slab. Remove the steel lid and dispose of it. Remove the foam plug and put in a safe location for subsequent use.

RUN SERVICES



Install services through the FyreBOX Cast-In as required, ensuring the services are approved for use. Refer to the FRL details section on pages 6 & 7 of this manual for details.

Click to Watch Installation Video



INSTALLATION

CONCRETE FLOOR SLABS

FOAM PLUG

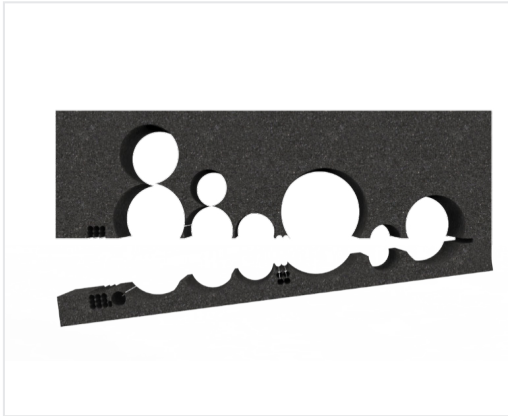

Retrieve the foam end plugs and cut a horizontal slit allowing you to open the foam. Cut out a rough profile of the services so that the foam can be fit snugly around them. Slide the foam over/ around the services and into the FyreBOX.

FIT THE FOAM



The foam fit should be snug, such that no daylight can be seen through the FyreBOX. Small gaps can be plugged with offcuts of foam and/or FyreFLEX® (or FyrePEX HP) sealant.

Tip: Use a hacksaw blade to cut the foam quickly and accurately.

WRAP



Where required, wrap the services with the appropriate length of TWRAP (per FRL tables above). Depending on the FRL, some cable trays require TWRAP infill material to pack out gaps before wrapping.

The TWRAP should overlap itself around the pipe by 50mm, if two strips are required to meet the appropriate length, then where the second length meets the first, a 50mm overlap is required. TWRAP is secured to the service used steel cable ties, 50mm from each end and 150mm centres in-between. TWRAP is applied to the top side of the floor slab only.

LABELING



Document the penetration. It is general good practice to take photographs and label all completed penetration works to add to the site's documentation for future inspections.

AS4072 includes some recommendations and templates for penetration register stickers.

[Click here to learn more or get your Penetration Seal Stickers now!](#)

Click to Watch Installation Video



INSTALLATION

FyreBOX Cast-In 350 x 125 (max)

FyreSET® Mortar

POSITION



Position the FyreBOX Cast-In in the desired penetration position and then nail/screw to the timber formwork through the flanges.

Z-CLIPS/POUR



Install 50 x 90 x 50mm steel z-clips to assist the mortar key into the slab. Fix them to the slab using M6 x 50mm Anchors. Pour FyreSET® Mortar to a minimum depth of 120mm.

Refer to [FyreSET® Mortar Technical Manual](#) for more installation details

SEAL



Seal the FyreBOX to the FyreSET® Mortar with a 25mm fillet of FyreFLEX® Sealant (this step not required for concrete slabs).

RUN SERVICES

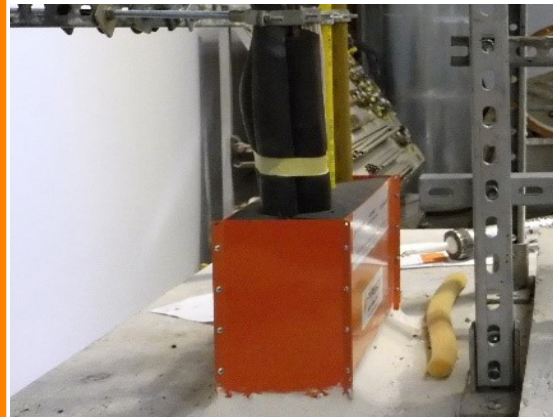

Install services through the FyreBOX Cast-In as required, ensuring the services are approved for use. Refer to the FRL details section on pages 6 & 7 of this manual for details.

Click to Watch Installation Video



FyreBOX Cast-In SYSTEMS



FyreBOX CAST-IN



Item Number	Description	Dimensions
FyreBOX-CI-175	175 x 125 x 380mm	
FyreBOX-CI-350	350 x 125 x 380mm	
FyreBOX-CI-550	550 x 125 x 380mm	
FyreBOX-CI-650	650 x 125 x 380mm	
FyreBOX-CI-1100	1100 x 125 x 380mm	
FyreBOX-CI-Custom	Any width up to 1250 x 125 x (Slab Depth + 50mm)	



FyreBOX Cast-In SYSTEM COMPONENTS

Item Number	Description	Min Order Qty	Pallet QTY
TWrap 300	300mm wide, 25mm thick blanket	7620mm long roll	24
TWrap 450	450mm wide, 25mm thick blanket	7620mm long roll	12
TWrap 600	600mm wide, 25mm thick blanket	7620mm long roll	12

FyreBOX Cast-In



COMPLIANCE WITH THE NATIONAL CONSTRUCTION CODE (NCC)

Formerly known as BCA

Under the NCC requirements, a multiple service transit system for service penetrations should be fire tested in every configuration that it is intended for use in, both completely empty (blank seal), partially full and completely full of services so that the product may be installed with as many or as little services as required on site. It is important to fire test in all the different walls types and with different configurations, quantities and types of services which is a time consuming (and expensive) exercise.

Trafalgar FyreBOX systems have been fire tested extensively to AS1530.4-2014 and approved in accordance with Section 4 AS4072.1 as required by Schedule 5 of the NCC. This includes over 200 hours of accredited furnace time and 30 plus individual test reports to cover the full range of service and wall configurations that allow us to comfortably stand behind our multiple SYSTEM approvals.

These configurations include but are not limited to:

- Service fill ratio: Empty (blank seal), half full and completely full of services
- Barrier types: Various types of plasterboard, concrete, Blockwork, Hebel, Walsc, Speedpanel, Pronto panel, FyreBOARD Maxilite board, concrete floors etc
- Services: Bare and insulated metal pipes, cable trays and cable bundles, PVC pipes & conduits, PEX and PEX-AL-PEX pipes, CPVC pipes etc
- Configurations: Blank seal (empty), full of services, double stacked, side by side etc
- Insulation performance: Tested both wrapped and unwrapped with TWRAP to ensure the system works in both configurations
- Penetration sizes: 150 x 125, 350x125, 550x125, 1100x125
- FyreBOX Variants: Slab Mount, Slab Mount Bambino, Cast-in, Maxi & Mini (retrofit)

When choosing a multiple service transit penetration system like FyreBOX, it is important to check that all aspects of your system have been fire tested and are fit for purpose.

Compliance will only be achieved when the installation on site mirrors the tested system. Please refer to the 'parent' fire stopping system product manuals for specific installation instructions.

TEST AND ASSESSMENT REPORTS

The above-mentioned fire testing reports have all been conveniently summarised into **BRANZ assessment report FC10266 (available on www.tfire.com.au)** which neatly tabulates the approved services in a range of fire barriers, for all FyreBOX variants and applications, and covers only minor variations to the tested systems, thereby providing trouble free certification according to NCC.

Importantly, every aspect of the assessment report are backed up by the fire test data and the individual fire test reports are available on request for certification purposes.

FAQ

Q Is the FyreBOX Cast-In suitable for my refrigeration lines?

A Yes, the FyreBOX Cast-In has been tested with both fire resistant (FR) and non-FR insulation and can be filled with as many lines as will reasonably fit in the box.

Q My certifier told me I need 2-hour insulation rating on my copper pipe penetrations – does the FyreBOX Cast-In achieve this?

A TWRAP (or FyreWrap®) will need to be wrapped around the FyreBOX to achieve an insulation rating. Contact Trafalgar Fire for installation details and refer to our YouTube channel for installation videos (<https://youtu.be/qo48SlxeLwc>).

Q Is the FyreBOX Cast-In approved for Bondek Floor slabs?

A Yes, Refer to our How to Install a FyreBOX Cast-In video or contact Trafalgar Fire Technical Team for further assistance.

Q Will an empty Fyrebox Cast In get 2 hours?

A An empty Fyrebox can achieve -/120/120 when a 20x20mm fillet of Fyreflex sealant is applied along the perimeter of the Fyrebox.

SOCIAL MEDIA



Fyrebox Cast In - Product Overview

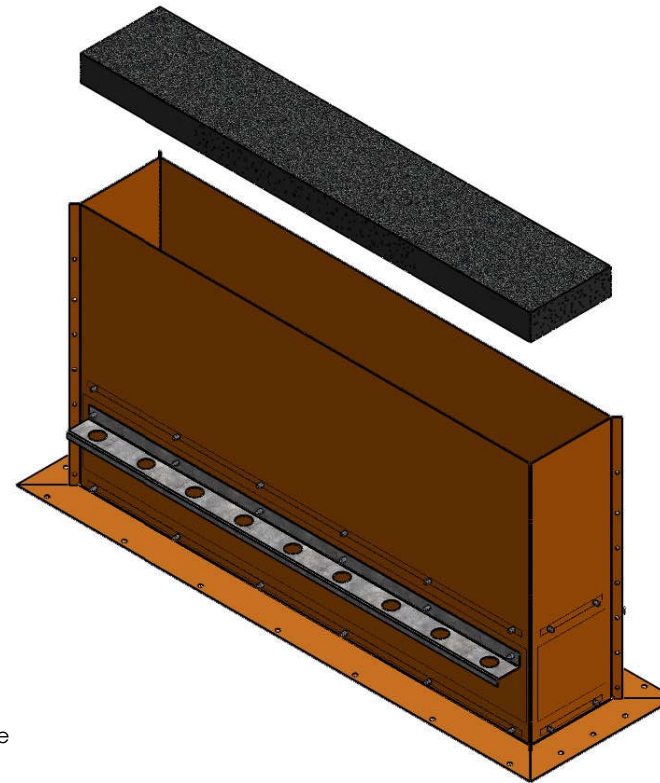
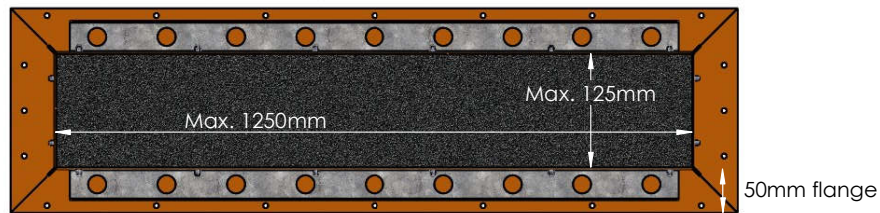

Drawing Name: Fyrebox Cast In Overview				Test Standard: AS1530.4	Codes:	Revision:	Date:	No.:	NOTICE:
Project Title: Fyrebox Cast In - Generic Install				Fire resistance level:	Drawn By: JC	<small>NOTE: ALL DIMENSIONS ARE IN MILLIMETRES (mm)</small>  Trafalgar Head Office: PO BOX 545 Chester Hill NSW 2162 T: 1800 888 714 F: 1800 201 500 E: info@tfire.com.au W: www.tfire.com.au			
Drawing No. : 1	Sheet: 1 of 5	Date: 27/05/2020	Scale: NTS	Based on Report No.:	Checked By: CT				

FyreBOX™ Cast-In - Installation Overview

STEP 1

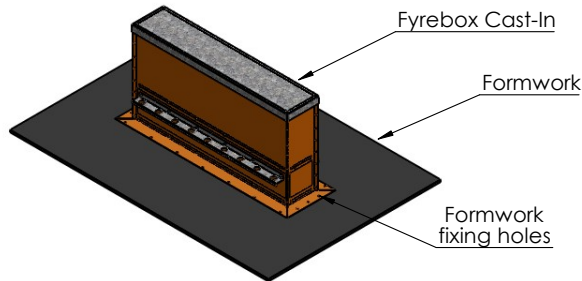

Secure FyreBOX™ Cast-In to formwork, through the fixing holes in the bottom flange

STEP 2

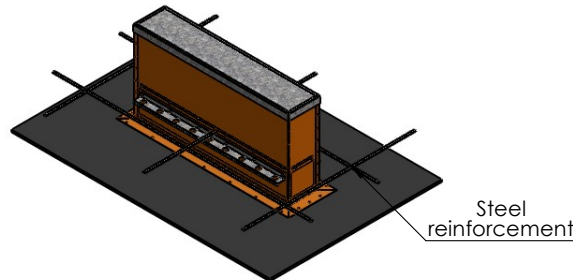

Install steel reinforcement, as required for concrete slab, around the FyreBOX™ Cast-In

STEP 3

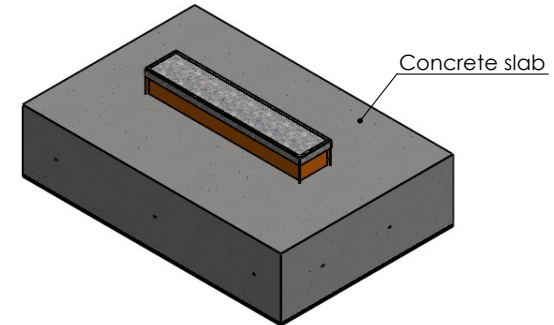

Cast concrete slab around FyreBOX™, to a minimum depth of 120mm

STEP 4

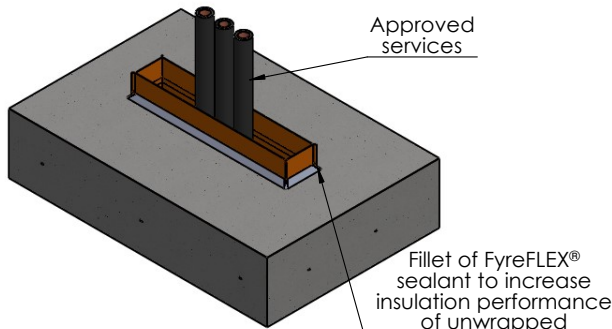

Install approved services through the FyreBOX™ Cast-In

STEP 5

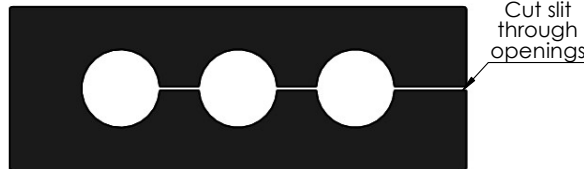

Retrieve foam end plugs and form openings to match the services within the FyreBOX™. Cutting a slit through these openings will allow for the plug to be opened and inserted around the existing services

STEP 6

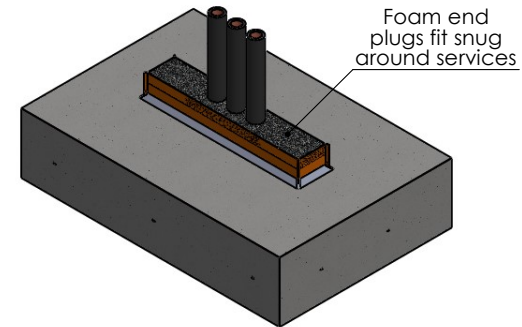

Fit foam end plugs tightly around the services, from each side of the FyreBOX™, and plug any gaps with foam off cuts or FyreFLEX® Sealant. Continue to 'TWrap' drawing if wrapping will be required for full insulation.

Drawing Name: Installation Overview

Project Title: FyreBOX™ Cast-In - Generic Install

Drawing No. :
2

Sheet:
2 of 5

Date:
27/05/2020

Scale:
NTS

Test Standard:
AS1530.4

Fire resistance level:

Based on Report No.:

Codes:

Drawn By:
JC

Checked By:
CT

Revision:

Date:

No.:

NOTICE:

NOTE: ALL DIMENSIONS ARE IN MILLIMETRES (mm)



STANDARD DRAWING
 PROJECT DRAWING

Concrete Slabs

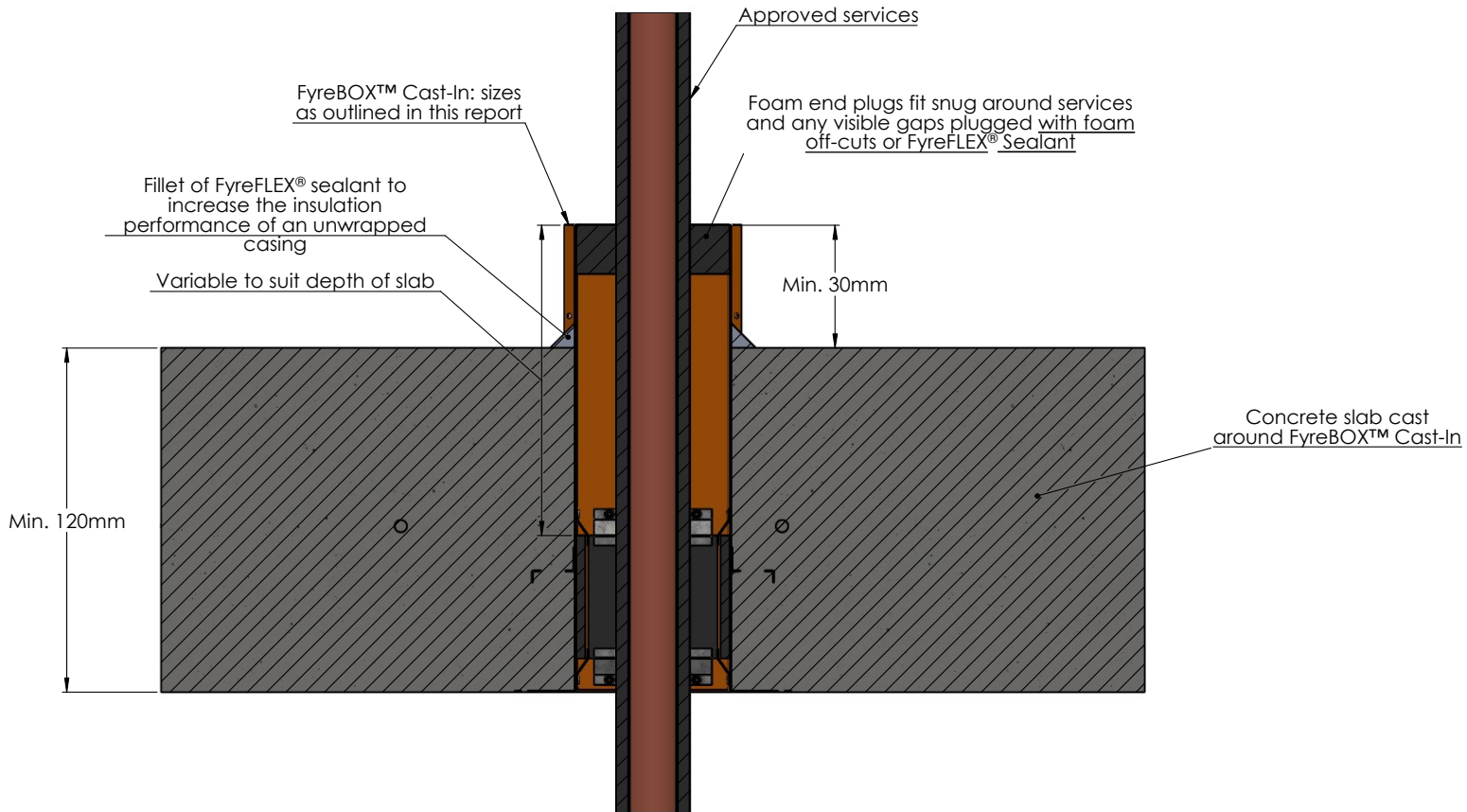

Drawing Name: Concrete Slab

Test Standard:
AS1530.4

Codes:

Revision:

Date:

No.:

NOTICE:

Project Title: FyreBOX™ Cast-In - Generic Install

Fire resistance level:

Drawn By:
JC

NOTE: ALL DIMENSIONS ARE IN MILLIMETRES (mm)

Drawing No. :
3

Sheet:
3 of 5

Date:
27/05/2020

Scale:
NTS

Based on Report No.:

Checked By:
CT

STANDARD DRAWING
 PROJECT DRAWING



Bondek Slabs (and/or similar with ribbed formwork)

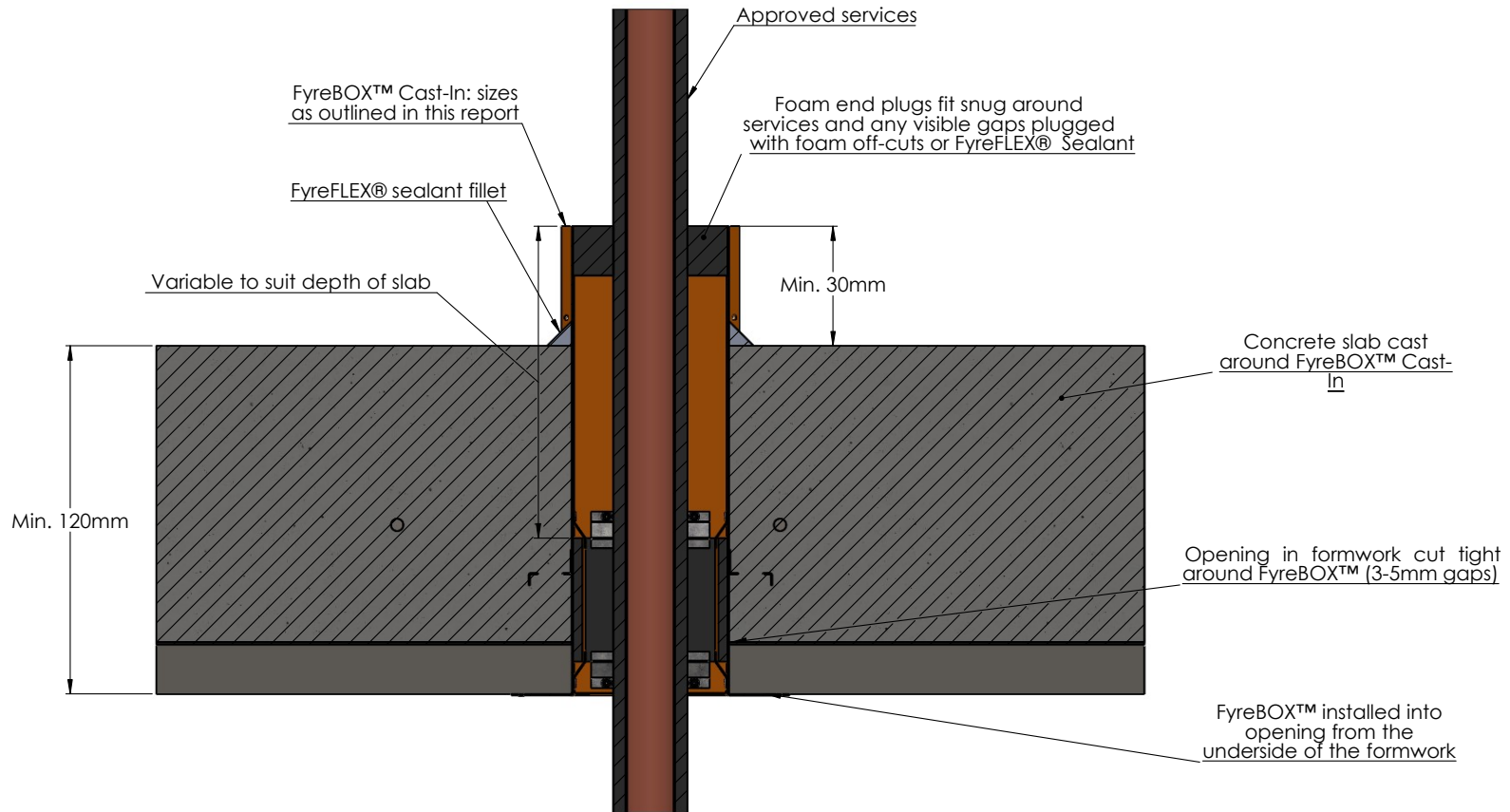

Drawing Name: Bondek				Test Standard: AS1530.4	Codes:	Revision:	Date:	No.:	NOTICE:
Project Title: FyreBOX™ Cast-In - Generic Install				Fire resistance level:	Drawn By: JC				<small>NOTE: ALL DIMENSIONS ARE IN MILLIMETRES (mm)</small>
Drawing No. : 4	Sheet: 4 of 5	Date: 27/05/2020	Scale: NTS	Based on Report No.:	Checked By: CT	<input type="checkbox"/> STANDARD DRAWING			
						<input type="checkbox"/> PROJECT DRAWING			

TWRAP - Fire Rated Floors

Where the FyreBOX™ and/or services do not achieve full insulation, TWRAP can be applied in order to increase this insulation rating up to -/XXX/120.

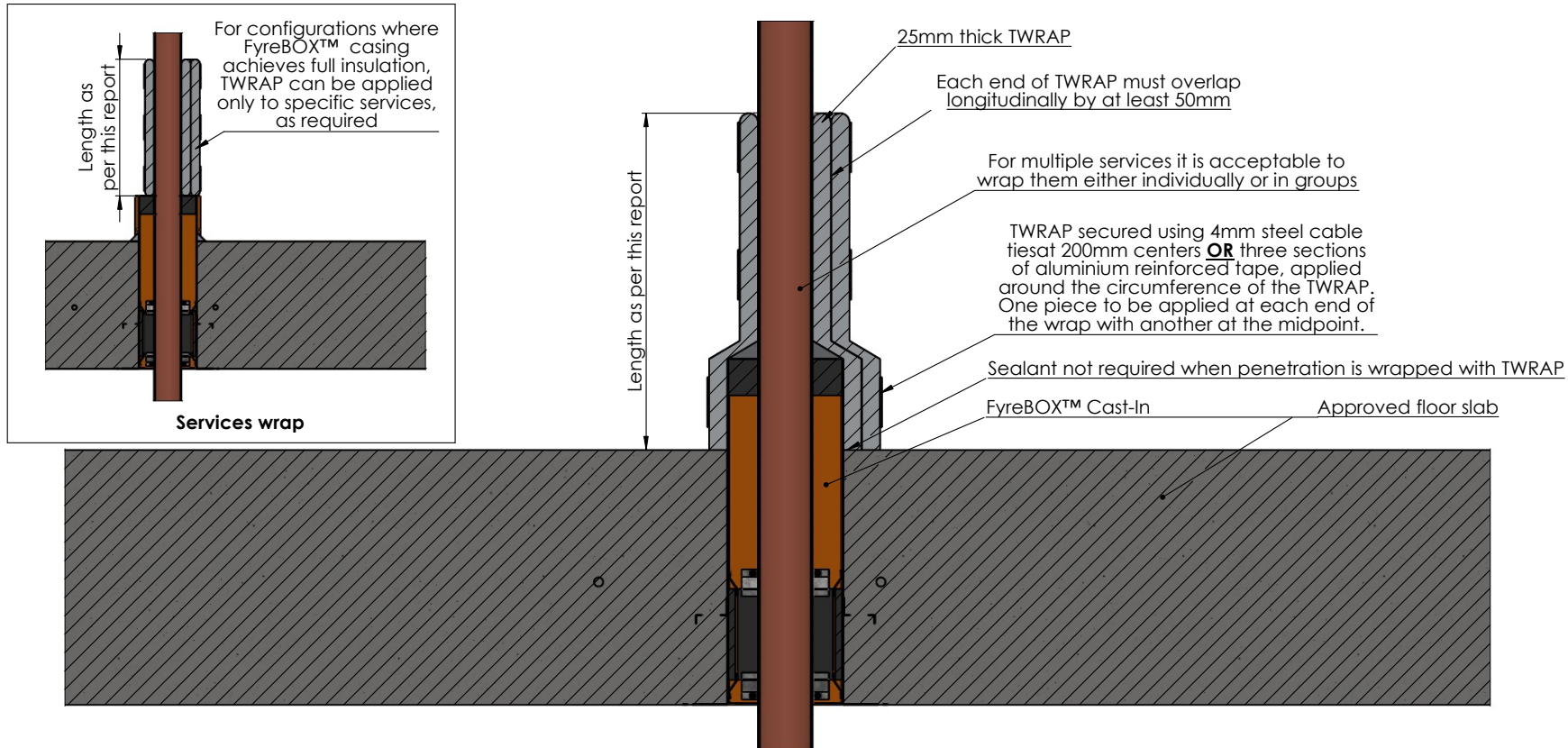

NOTES:

- Cable trays require TWRAP infill material to be packed in between cable groupings to the full depth of the cable tray for 300mm away from the FyreBOX™ prior to being wrapped with TWRAP

Drawing Name: TWRAP				Test Standard: AS1530.4	Codes:	Revision:	Date:	No.:	NOTICE:
Project Title: FyreBOX™ Cast-In - Generic Install				Fire resistance level:	Drawn By: JC	<small>NOTE: ALL DIMENSIONS ARE IN MILLIMETRES (mm)</small>			
Drawing No. : 5	Sheet: 5 of 5	Date: 27/05/2020	Scale: NTS	Based on Report No.:	Checked By: CT	<input type="checkbox"/> STANDARD DRAWING <input type="checkbox"/> PROJECT DRAWING			



FyreBOX™ Cast-In In Close Proximity - Floors

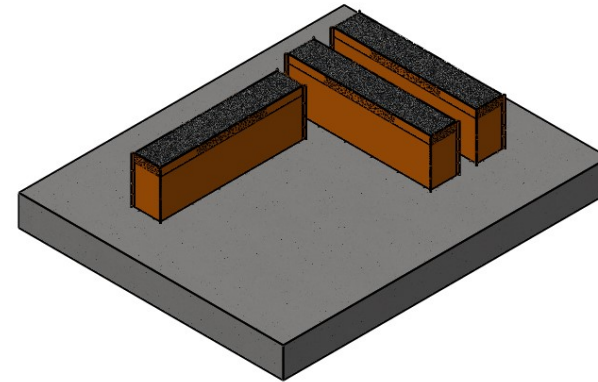
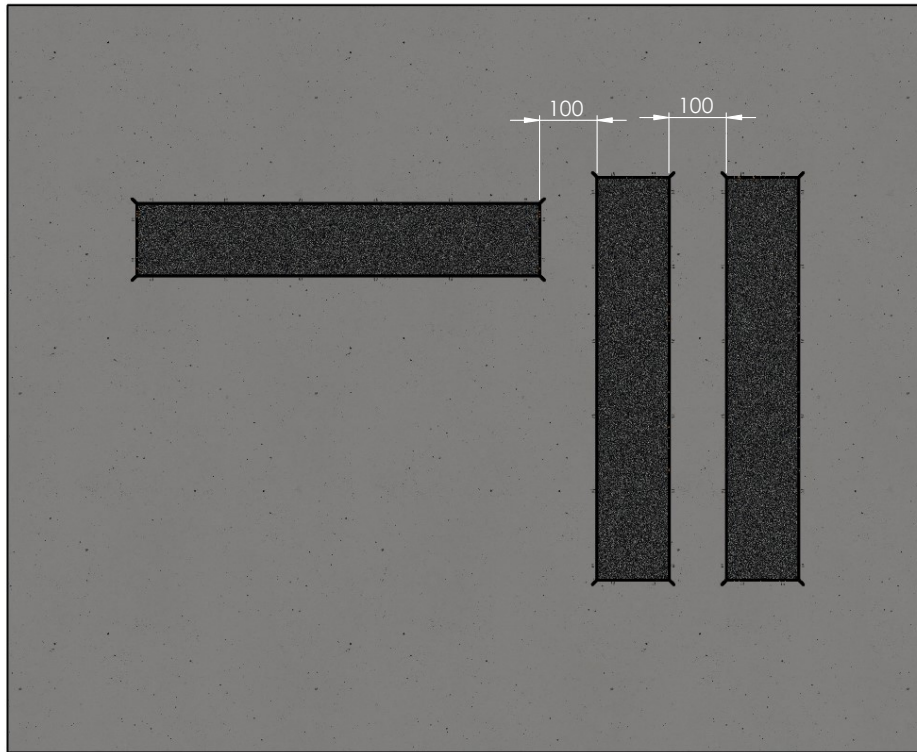

Key	FyreBOX™ Configuration	Minimum Separation Requirement
A	Cast-In to Cast-In (long edges)	100mm between penetrations (Edge of bottom formwork flanges touching)
B	Cast-In to Cast-In (short edges)	100mm between penetrations (Edge of bottom formwork flanges touching)

NOTES:

Barrier must be designed or approved for the openings/spacing required

Drawing Name: FireBOX™ In Proximity - Floors				Test Standard: AS1530.4	Codes:	Revision:	Date:	No.:	NOTICE:
Project Title: FireBOX™ Install Variations				Fire resistance level:	Drawn By: JC	NOTE: ALL DIMENSIONS ARE IN MILLIMETRES (mm)			
Drawing No. : 2	Sheet: 2 of 9	Date: 27/05/2020	Scale: NTS	Based on Report No.:	Checked By: CT				



Applying TWrap to metal pipes above NB50

- Twrap applied around pipes first for large pipes, specific lengths as detailed in this report for pipes greater than NB50.
- Each section of TWrap secured using 4mm wide steel cable ties at 200mm centers **OR** three sections of aluminium reinforced tape, applied around the circumference of the Twrap. One piece to be applied at each end of the wrap with another at the midpoint.
- Secondary wrap applied around casing / all other services (as needed) for standard lengths as per this report

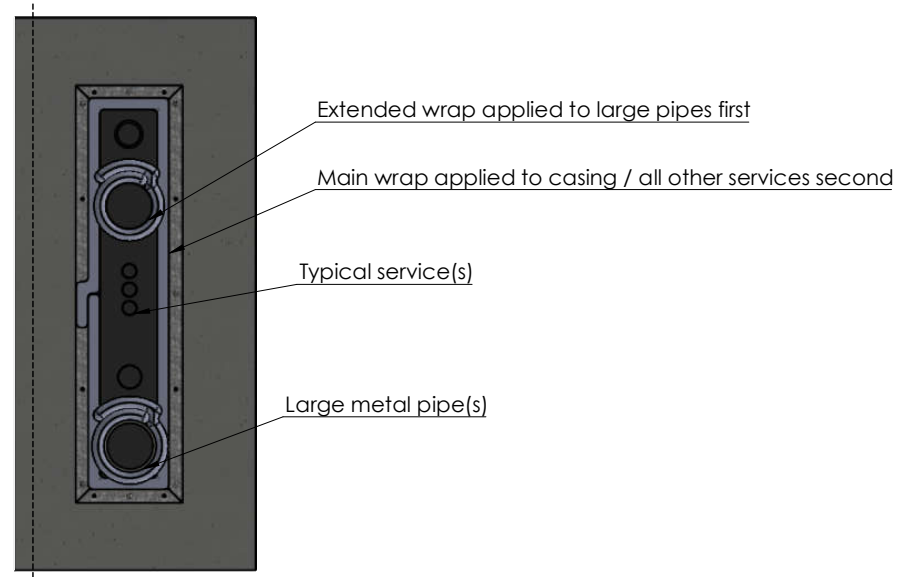
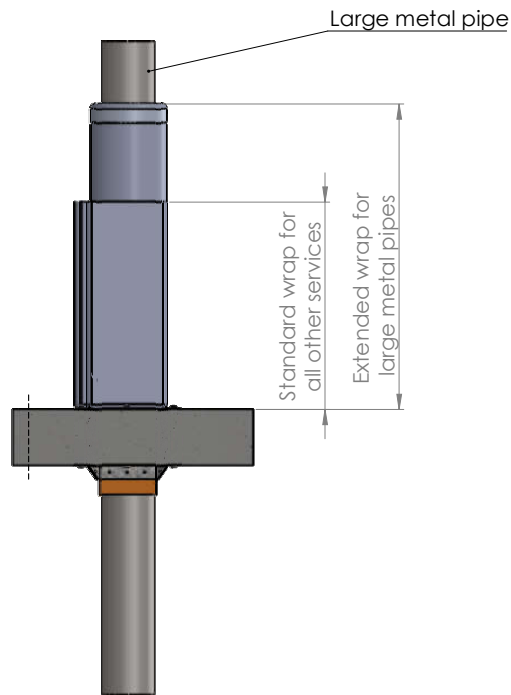

- NOTES:**
- TWrap is required on both sides of wall penetrations.
 - Cable trays require infill material as-tested before wrapping

Drawing Name: TWrap - Large metal pipes				Test Standard: AS1530.4	Codes:	Revision:	Date:	No.:	NOTICE:
Project Title: Fyrebox Maxi - Generic Install				Fire resistance level:	Drawn By: JC				<small>NOTE: ALL DIMENSIONS ARE IN MILLIMETRES (mm)</small>  Trafalgar Head Office: PO BOX 545 Chester Hill NSW 2162 T: 1800 888 714 F: 1800 201 500 E: info@tfire.com.au W: www.tfire.com.au
Drawing No. : 16	Sheet: 16 of 16	Date: 13/07/2020	Scale: NTS	Based on Report No.:	Checked By: CT	<input type="checkbox"/> STANDARD DRAWING <input type="checkbox"/> PROJECT DRAWING			