

# The fire resistance of Fyreflex sealant and Twrap/Monowrap/Fyrewrap protecting pipes and cables in accordance with AS 1530.4 – 2014 and AS 4072.1 – 2005 Amdt. 1

## Assessment Report

**Author:** Keith Nicholls

**Assessment Number:** FCO-1579

**Quote Number:** CO5556

**Date:** 31/1/2023

**Version:** Revision H

**The Client:** Trafalgar Group PTY LTD

Commercial-in-confidence

## Inquiries should be addressed to:

Fire Testing and Assessments  
NATA Registered Laboratory  
14 Julius Avenue  
North Ryde, NSW 2113  
Telephone +61 2 94905444

Author  
Infrastructure Technologies  
14 Julius Avenue  
North Ryde, NSW 2113  
Telephone +61 2 94905500

The Client(s)  
Trafalgar Group PTY LTD 26A  
Ferndell Street  
South Granville, NSW, 2142  
Telephone 1800 888 714

## Report Details:

Report CSIRO Reference number: FCO-1579/ CO5556

## Report Status and Revision History:

VERSION	STATUS	DATE	DISTRIBUTION	ISSUE NUMBER
Initial Issue	Final	25/3/2014	Client/CSIRO	FCO-1579 Ver25Mar14.
Revision A	Final	21/6/2019	Trafalgar/CSIRO	FCO-1579
Revision B	Final	2/4/2020	Trafalgar/CSIRO	FCO-1579
Revision C	Final	4/6/2020	Trafalgar/CSIRO	FCO-1579
Revision D	Final	26/11/2020	Trafalgar/CSIRO	FCO-1579
Revision E	Final	15/3/2021	Trafalgar/CSIRO	FCO-1579
Revision F	Final	31/10/2022	Trafalgar/CSIRO	FCO-1579
Revision G	Final	20/12/2022	Trafalgar/CSIRO	FCO-1579
Revision H	Final	31/1/2023	Trafalgar/CSIRO	FCO-1579

## Report Authorization:

AUTHOR	REVIEWED BY	AUTHORISED BY
Keith Nicholls	Jing Xu	Brett Roddy



31/1/2023

31/1/2023

31/1/2023

## Copyright and disclaimer

© 2023 CSIRO To the extent permitted by law, all rights are reserved and no part of this publication covered by copyright may be reproduced or copied in any form or by any means except with the written permission of CSIRO.

## Important disclaimer

CSIRO advises that the information contained in this publication comprises general statements based on scientific research. The reader is advised and needs to be aware that such information may be incomplete or unable to be used in any specific situation. No reliance or actions must, therefore, be made on that information without seeking prior expert professional, scientific and technical advice. To the extent permitted by law, CSIRO (including its employees and consultants) excludes all liability to any person for any consequences, including but not limited to all losses, damages, costs, expenses and any other compensation, arising directly or indirectly from using this publication (in part or in whole) and any information or material contained in it.

# Contents

1	Introduction .....	4
2	Supporting Data .....	4
3	Proposed Variations .....	6
4	Referenced Standards .....	10
5	Conclusion .....	10
6	Direct Field of Application of Results .....	33
7	Requirements .....	33
8	Term of Validity .....	34
9	Limitations .....	34
Appendix A	Supporting Test Data .....	35
Appendix B	Analysis of Variations .....	58

Property of Trafalgar Group

# 1 Introduction

This report is an assessment of the fire resistance of Fyreflex sealant and Twrap/Monowrap /Fyrewrap protecting pipes and cables in accordance with AS 1530.4 – 2014 and AS 4072.1 – 2005 Amdt. 1.

This report supersedes all previous versions.

This report is prepared for the purpose of meeting the requirements of NCC 2019 Volume 1 Admt. 1 Schedule 5 Clause 2 (b) and (c) or NCC 2022 Volume 1 Clause S1C2 b) and c) as appropriate for FRL.

This report reviews and confirms the extent to which the reference tests listed in Section 2 meet the requirements of the test standards listed in Section 4 of the report. The proposed variations to the tested construction presented in Section 3 are subject to an analysis in Appendix B, and the conclusions are presented in Section 5 of this report.

The field of applicability of the results of this assessment report is presented in Section 6 and subject to the requirements, validity and limitations of Sections 7, 8 and 9.

# 2 Supporting Data

This assessment report refers to various test reports to support the analysis and conclusions of this report. They are listed below;

Report Reference	Test Standard	Outline of Test Specimen
NI 1089	AS 1530.4 -1985	A fire resistance test on a 115mm thick slab mortar penetrated by various penetrations and protected by Fyreflex sealant.
NI 2689	AS 1530.4 -1985	A fire resistance test on a 75mm thick E core panel penetrated by various penetrations and protected with Fyreflex.
NI 3089	AS 1530.4 -1985	A fire resistance test on 125mm thick Bondek slab penetrated by various penetrations and protected by Fyreset mortar and Fyreflex sealant.
FSP 0768	AS 1530.4 -1997	A fire resistance test on 80mm thick Fyreset mortar and 5mm Hardiflex penetrated by various penetrations and protected by Fyreflex sealant.
EWFA 51894700.1	AS 1530.4 -2014	A fire resistance test on a 175mm thick concrete slab penetrated by various pipes and cables protected by Trafalgar Fyrebox Maxi and Fyrebox Mini, Fyrebox Cast-in penetration protection systems.
FSP 2052	AS 1530.4 -2014	A fire resistance test on a 150mm thick concrete slab penetrated by two electrical cable trays and three separate bundles of cables.
FRT 190292.5	AS 1530.4 -2014	A fire resistance test on a 175mm thick concrete slab penetrated by various services protected with various fire stop systems.
FRT 180931.1	AS 1530.4 -2014	A fire resistance test on a 175mm thick concrete slab penetrated by various services protected with various fire stop systems.
FP 11935-001	AS 1530.4 -2014	A fire resistance test on a 116mm plasterboard lined stud wall penetrated by various services protected with various fire stop systems.
FRT 180392.1	AS 1530.4 -2014	A fire resistance test on a 116mm plasterboard lined stud wall penetrated by various services protected with various fire stop systems.

Report Reference	Test Standard	Outline of Test Specimen
FP 6033	AS 1530.4 -2014	A fire resistance test on a 90mm plasterboard lined stud wall penetrated by various services protected with various fire stop systems.
FSP 1729A	AS 1530.4 -2014	A fire resistance test on a 96mm plasterboard lined stud wall penetrated by various services protected with various fire stop systems.
FSP 1795	AS 1530.4 -2014	A fire resistance test on a 75mm Hebel wall penetrated by various services protected with various fire stop systems.
FRT 180323 R4.0	AS 1530.4 -2014	A fire resistance test on a 78mm Speedpanel wall penetrated by various services and protected with various fire stop systems.
FP 6372	AS 1530.4 -2014	A fire resistance test on a 75mm Hebel wall penetrated by various services protected with various fire stop systems.
FSP 1753	AS 1530.4 -2014	A fire resistance test on a 75mm Hebel wall penetrated by various services protected with various fire stop systems.
FRT 190298 R1.1	AS 1530.4 -2014	A fire resistance test on a 78mm Speedpanel wall penetrated by various services and protected with various fire stop systems.
FSP 2146	AS 1530.4 -2014	A fire resistance test on a 150mm thick concrete slab penetrated by various services protected with various fire stop systems.
FRT 200160.2	AS 1530.4 -2014	A fire resistance test on a 60mm Pronto Panel wall penetrated by various services protected with various fire stop systems.
FRT 200397 R1.2	AS 1530.4 -2014	A fire resistance test on a 78mm Speedpanel wall penetrated by various services and protected with various fire stop systems.
FRT 210467	AS 1530.4 -2014	A fire resistance test on a 150mm thick concrete slab penetrated by various services and protected with various fire stop systems.
FSP 2317	AS 1530.4 -2014	A fire resistance test on a 150mm thick concrete slab penetrated by various services and protected with various fire stop systems.
FRT 220112	AS 1530.4 -2014	A fire resistance test on various specimens penetrating a Corex board wall system
FSP 2230	AS 1530.4 -2014	A fire resistance test on various services penetrating a 41mm thick plasterboard wall system

The tests NI 1089, NI 2689 and NI 3089 were tested by Fire Research Laboratories and sponsored by Wormald International. Permission has been given for the use of these reports for this assessment.

The test FSP 0768 was undertaken by CSIRO North Ryde and sponsored by Tyco Passive Fire protection. Permission has been given for the use of these reports for this assessment.

The tests FRT 220112, EWFA 51894700.1, FRT 180323 R4.0, FRT 190298 R1.1, FRT 190292.5, FRT 180931.1 and FRT 180392.1, FRT 200160.2 and FRT 200397 R1.2, and FRT 210467 were undertaken by Exova Warrington Fire and sponsored by Trafalgar Fire.

The tests FSP 2052, FSP 1729A, FSP 1795 and FSP 1752 were undertaken by CSIRO North Ryde and sponsored by Fire Containment Pty Ltd.

The tests FP 11935-001, FP 6033 and FP 6372 were undertaken by Branz, NZ and sponsored by Fire Containment Pty Ltd.

The tests FSP 2230, FSP 2146 and FSP 2317 were undertaken by CSIRO North Ryde and sponsored by Trafalgar Group Pty Ltd.

## 3 Proposed Variations

### 3.1 Metal pipes penetrating floors - without wrap

The proposed construction shall be for penetrations in concrete floors as tested in NI 1089, NI 2689, NI 3089, and FSP 0768, when subject to the following variations;

- Variation of slab thickness to 120mm where possible.
- Change the gap around the pipe to be up to 20mm.
- Variation to sealant depth to be 30mm to 115mm and fillet size to be 20mm x 50mm or 50mm x 50mm.
- Variations in pipe size and pipe materials as shown in Table 1.
- The separation of the specimens shall be at least 40mm refer to Figure 5a

**Table 1: Metal pipes**

Pipe material	Nominal pipe diameter OD
Brass	Up to 100mm (Max. 1.2mm wall thickness)
Copper Type B	Up to DN150
	DN200
Steel (Medium Grade)	Up to NB150
	NB200 (Max. 5mm wall thickness)

### 3.2 Metal pipes penetrating floors - protected with wraps

The proposed construction comprises metal pipe penetrations in floors as tested in FRT180391, FRT 190292.5, FSP 2146 and FSP 2317 when subject to the following variations;

- Variation of slab thickness to 120mm where possible.
- Change the gap around the pipe to be up to 20mm.
- Variation to sealant depth to be 50mm or 60mm and the fillet size to be based on design
- Variations in pipe size and materials as shown in Table 2.
- Inclusion of services wrapped with either
  - o Fyrewrap (38mm thick Fyrewrap Elite 1.5 ceramic fibre blanket (aluminium faced) with a density of 96 kg/m<sup>3</sup>) or
  - o Twrap (25mm thick Twrap fire blanket (aluminium faced) with a density of 128 kg/m<sup>3</sup>) or
  - o Monowrap (40mm thick Mineral fibre wool (aluminium faced on the outer face only) with a density of 80kg/m<sup>3</sup>)
- Wrap to be installed with overlap as per Figure 2-4
- The inclusion of an optional fillet of Fyreflex sealant per Figure 5
- The separation of the specimens shall be at least 40mm refer to Figure 5b

**Table 2: Metal pipes in concrete slabs with Twrap**

Pipe material	Nominal pipe diameter OD
Copper Type B	Up to DN150
Steel (Medium Grade)	Up to NB150
Stainless Steel	Up to 170mm and a minimum 1.5mm wall thickness

### 3.3 Metal pipes penetrating walls - protected with wrap

The proposed construction comprises metal pipes tested in FRT 180392.1, FP 6033, FP 6372, FSP 1753, FRT 190298 R1.1, FP 11935-001, FRT 200160.2, FRT200397 R1.2 and FSP 2317 when subject to the following variations:

- Variations in pipe size and materials as shown in Table 2
- The gap between the pipe and wall opening to be a maximum of 10mm
- Fyreflex size based on design
- Variation of wrap length based on design
- Variation to wall type an inclusion of a localised wall thickening
- Inclusion of services wrapped with either
  - o Fyrewrap (38mm thick Fyrewrap Elite 1.5 ceramic fibre blanket (aluminium faced) with a density of 96 kg/m<sup>3</sup>) or
  - o Twrap (25mm thick Twrap fire blanket (aluminium faced) with a density of 128 kg/m<sup>3</sup>)
- Wrap to be installed with overlap as per Figure 9-11
- The inclusion of an optional fillet of Fyreflex sealant per Figure 5
- The separation of the specimens shall be at least 40mm refer to Figure 5b

### 3.4 Cable penetrating floors – discontinuous cable tray without wrap

The proposed construction shall be for cables as tested in NI 1089, NI 2689 and EWFA 51894700.1 when subject to the following variations;

- Variation of slab thickness to 120mm where possible
- Variation to include cable tray for 1m on either side of the concrete slab no closer than 100mm from the slab on each side.
- Sealant depth and fillet size shall vary.
- The separation of the specimens shall be at least 40mm refer to Figure 5a

### 3.5 Cable penetrating floors – continuous cable tray protected with wrap

The proposed construction shall be for cables as tested in FSP 2052, FRT 190292.5 and FRT 180931.1 and FSP 2249 when subject to the following variations;

- The inclusion of min. 120mm thick slab thickness penetrated by specimen as tested in FSP 2052 specimens 3, 4 and 5
- The inclusion of 120mm and 175mm thick slab penetrated by specimen as tested in FRT 190292.5 specimen E1
- The inclusion of 175mm thick slab penetrated by specimen as tested in FRT 190292.5 specimen E1, with 630mm<sup>2</sup> single core cable removed, and protected two layers of 450mm length of Twrap on specimen instead of tested one layer
- The inclusion of a 120mm thick slab penetrated by specimen as tested in FRT 180931.1 specimen C, with 630mm<sup>2</sup> single core cable removed
- The inclusion of services wrapped with either
  - o Fyrewrap (38mm thick Fyrewrap Elite 1.5 ceramic fibre blanket (aluminium faced) with a density of 96 kg/m<sup>3</sup>) or
  - o Twrap (25mm thick Twrap fire blanket (aluminium faced) with a density of 128 kg/m<sup>3</sup>) or
  - o Monowrap (40mm thick Mineral fibre wool (aluminium faced on the outer face only) with a density of 80kg/m<sup>3</sup>)
- Wrap to be installed with overlap as per Figures 13 and 14
- The inclusion of an optional fillet of Fyreflex sealant per Figure 5
- The separation of the specimens shall be at least 40mm refer to Figure 5b

### 3.6 Cable penetrating walls – continuous cable tray protected with wrap

The proposed construction comprises cables tested in FP 11935, FRT 180392.1, FP 6033, FSP 1729A, FSP 1795 and FRT 180323 R4.0 when subject to the following variation:

- The inclusion of min. 75mm thick double caged Hebel wall, min. 78mm thick Speedpanel wall, min. 120mm thick concrete wall and 130mm thick masonry wall designed in accordance with AS 3700 for an FRL of -/180/120 as barriers penetrated by FP 11935 specimen 3
- The inclusion of cable bundles of up to 10 x CAT 6 or 10 x TPS cables as tested in FRT 180392.1 specimen J, with a maximum gap between cable and wall to be 20mm
- The inclusion of cable bundles of up to 8 x 3C+E power cables as tested in FRT 180392.1 specimen C
- The inclusion of cable bundles of up to 3 x 19 mm OD, 3C+E power cables as tested in FP 6033 specimen 8
- The inclusion of cable bundles of up to 3 x 19 mm OD, 3C+E power cables as tested in FP 6033 specimen 8 penetrating a min. 96mm thick plasterboard lined stud wall lined with a layer of 16mm fire rated plasterboard on each side of the stud.
- The inclusion of cable bundles of up to 3 x 19 mm OD, 3C+E power cables as tested in FP 6033 specimen 8 penetrating a min. 96mm thick plasterboard lined stud wall lined with a layer of 16mm fire rated plasterboard on each side of the stud and 16mm FR patch on each side
- The inclusion of cable bundles of up to 5 x CAT 6 or 5 x TPS cables as tested in FSP 1729A specimen 2
- The inclusion of cable bundles of up to 4 x CAT 6 or 4 x TPS cables as tested in FSP 1795 specimen 2
- Cables as tested in FRT 180323 R4.0 specimen H, with an increase sealant size to 50mm and the inclusion of 300mm Twrap on each side of penetration.
- The inclusion of cable bundles of up to 4 x CAT6 cables or 4 x 2C+E Prysmian cables or 4 x Firesense TP cables as tested in FRT 180323 R4.0 specimen G, with a maximum gap between cable and wall to be 5mm and an increase sealant fillet size to 50mm
- The inclusion of up to 4 x 6mm OD RG6 coax cables as tested in FSP 2249 specimen 4 installed in various wall types with annular gaps no greater than 5mm:
  - o 75mm single mesh AAC, Fyreflex sealant to the full depth of the wall and 30mm x 30mm fillet on each side.
  - o 75mm double mesh AAC, Fyreflex sealant to the full depth of the wall and 30mm x 30mm fillet on each side.
  - o 78mm Speedpanel, min. 130mm Masonry/concrete wall with Fyreflex sealant to the full depth of the wall and 30mm x 30mm fillet on each side.
  - o 2 x min. 13mm layered plasterboard wall system, sealant to the full depth of lining and 30mm fillet sealant + 300mm Twrap on each side of the wall.
  - o 1 x min. 13mm layered plasterboard wall system + 1 x min. 13mm FR patch on each side, sealant to the full depth of lining and 50mm fillet sealant on each side of the wall.
- Addition of 90 minute Corex wall constructions (2x20mm Corex boards on steel stud) as tested in FRT 220112 when penetrated by the following services
  - o Steel and copper pipes up to 100mm with 600mm TWrap and 15mm fillets of FyreFLEX sealants based on FRT 220112 specimen G
  - o Steel and copper pipes up to 50mm with 300mm TWrap and 15mm fillets of FyreFLEX sealants based on FSP 2230 specimen 4
  - o Stainless steel pipe up to 100mm with 600mm Twrap, with a layer of 100mm width x 60mm Maxilite Pad or 3 layers of 100mm width x 20mm thick Corex boards Pad on one side
  - o Include three additional service penetrations that are protected as tested in FRT220112 specimen A and include one of the following cable types



- Up to 30 x TPS cables 2.5mm<sup>2</sup>
    - Up to 30 x TPS fire 1.5mm<sup>2</sup>
    - Up to 30 x CAT6 cables,
  - Include up to 8 x 19mm OD, 3C+E 16mm<sup>2</sup> power cables protected as tested in FRT220112 specimen E
- Addition of 120 minute Corex wall constructions (2x25mm Corex boards on steel stud) as tested in FRT 220112 when penetrated by the following services
  - Steel and copper pipes up to 100mm with 600mm TWrap and 15mm fillets of FyreFLEX sealants based on FRT 220112 specimen G
  - Stainless steel pipe up to 100mm with 600mm Twrap, with a layer of 100mm width x 60mm thick Maxilite Pad or 2 layers of 100mm width x 25mm thick Corex boards Pad on each side
  - Include three additional service penetrations that are protected as tested in FRT220112 specimen A and include one of the following cable types
    - Up to 30 x TPS cables 2.5mm<sup>2</sup>
    - Up to 30 x TPS fire 1.5mm<sup>2</sup>
    - Up to 30 x CAT6 cables,
  - Include up to 8 x 19mm OD, 3C+E 16mm<sup>2</sup> power cables protected as tested in FRT220112 specimen E
- Addition of various combinations of Eltech VRF cables (7mm total OD with 1.5mm diameter conductor, part number ELT7501P), installed in the following wall types
  - 120 minute 116mm or thicker plasterboard system
    - up to 6 x VRF cables
    - Protection as per 10 x TPS cables in 120mm thick plasterboard system
  - 90 minute 96mm or thicker plasterboard system
    - up to 5 x VRF cables
    - Protection as per 5 x TPS cables in 96mm thick plasterboard system
  - 90 minute 75mm or thicker Hebel panel
    - up to 4 x VRF cables
    - Protection as per 4 x TPS cables in 90 minutes 75mm Hebel panel
  - 120 minute 78mm or thicker Speedpanel
    - up to 4 x VRF cables
    - Protection as per 4 x TPS cables in 120 minutes 78mm thick Speedpanel
  - 90 minute 2x20mm Corex board lined wall including
    - up to 5 x VRF cables
    - annular gaps to be ≤5mm and fully filled with Fyreflex sealant
    - 30mm x 30mm fillet of Fyreflex sealant on each side of the cable
    - 300mm Twrap on each side of the cable
  - 120 minute 2x25mm Corex board lined wall including
    - up to 5 x VRF cables
    - annular gaps to be ≤5mm and fully filled with Fyreflex sealant
    - 30mm x 30mm fillet of Fyreflex sealant on each side of the cable
    - 300mm Twrap on each side of the cable
- The inclusion of services wrapped with either
  - Fyrewrap (38mm thick Fyrewrap Elite 1.5 ceramic fibre blanket (aluminium faced) with a density of 96 kg/m<sup>3</sup>) or
  - Twrap (25mm thick Twrap fire blanket (aluminium faced) with a density of 128 kg/m<sup>3</sup>)
- Wrap to be installed with overlap as per Figure 13
- The inclusion of an optional fillet of Fyreflex sealant per Figure 5
- The separation of the specimens shall be at least 40mm refer to Figure 5b
- For services in plasterboard and Corex lined stud walls, the hole for the service shall be located at least 100mm away from wall studs and the head of the wall to facilitate the application of the wrap

## 4 Referenced Standards

Standards:

AS 1530.4 – 2014	Methods for fire tests on building materials, components and structures Part 4: Fire resistance tests of elements of building construction.
AS 4072.1 – 2005 Amdt. 1	Components for the protection of openings in fire-resistant separating elements, Part 1: Service penetrations and control joints.

## 5 Conclusion

On the basis of the analysis presented in this report, it is the opinion of this Accredited Testing Laboratory that the tested prototypes described in Section 2 when varied as described in Section 3 will achieve the performance below when submitted to a test in accordance with the test methods referenced in Section 4, and subject to the requirements of Section 7, the validity of Section 8 and limitation of Section 9.

### 5.1 Metal pipes penetrating floors - without wrap

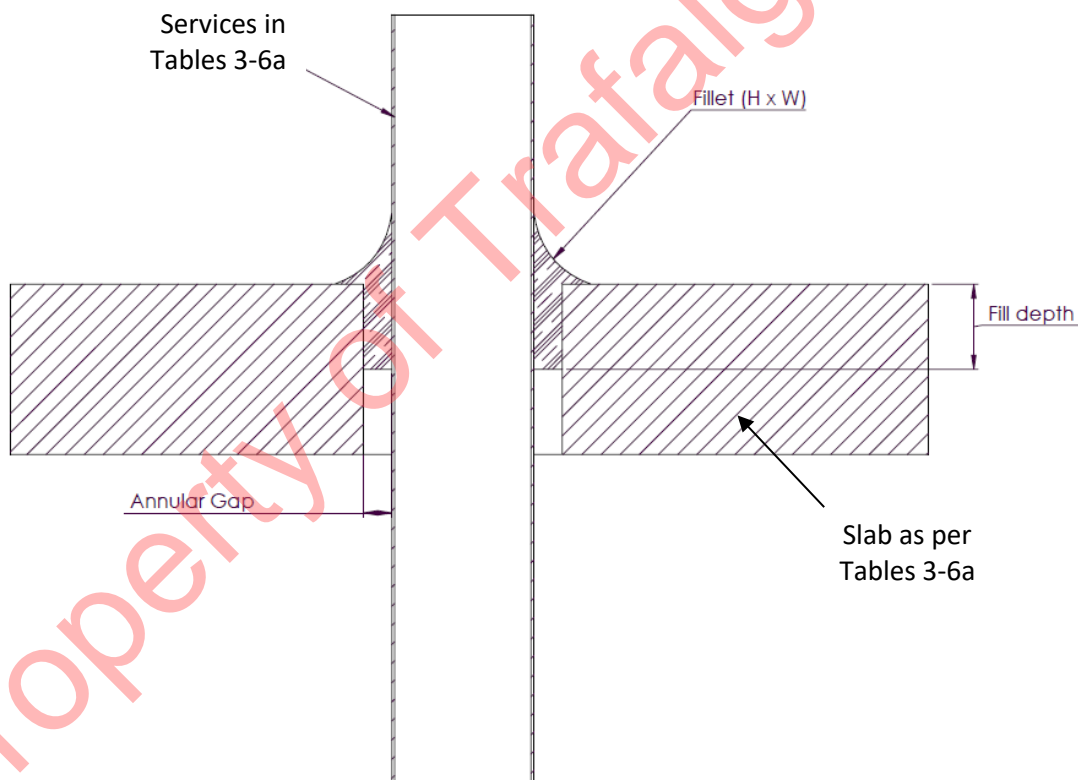


Figure 1: General services to slab sealant detail

**Table 3: FRL of metal pipes penetrating a 120mm or thicker concrete slab**

Pipe material	Nominal pipe diameter OD	The gap between pipe and slab (mm)	Min. Fyreflex sealant depth (mm)	Min. Fyreflex sealant fillet on the unexposed side (h x w) (mm)	Figures	FRL
Brass	Up to 100mm and 1.2mm wall thickness	10 -20	30	20x50	1, 5a	-/120/-
Copper Type B	Up to DN150	10 -20	30	20x50		-/120/-
	DN200	10 -20	30	50x50		-/120/-
Steel Medium Grade	Up to NB100	10 -20	50	20x50		-/120/15
	Up to NB150	10 -20	30	20x50		-/120/-
	NB200 and (Max. 5mm wall thickness)	10 -20	30	50x50		-/120/-

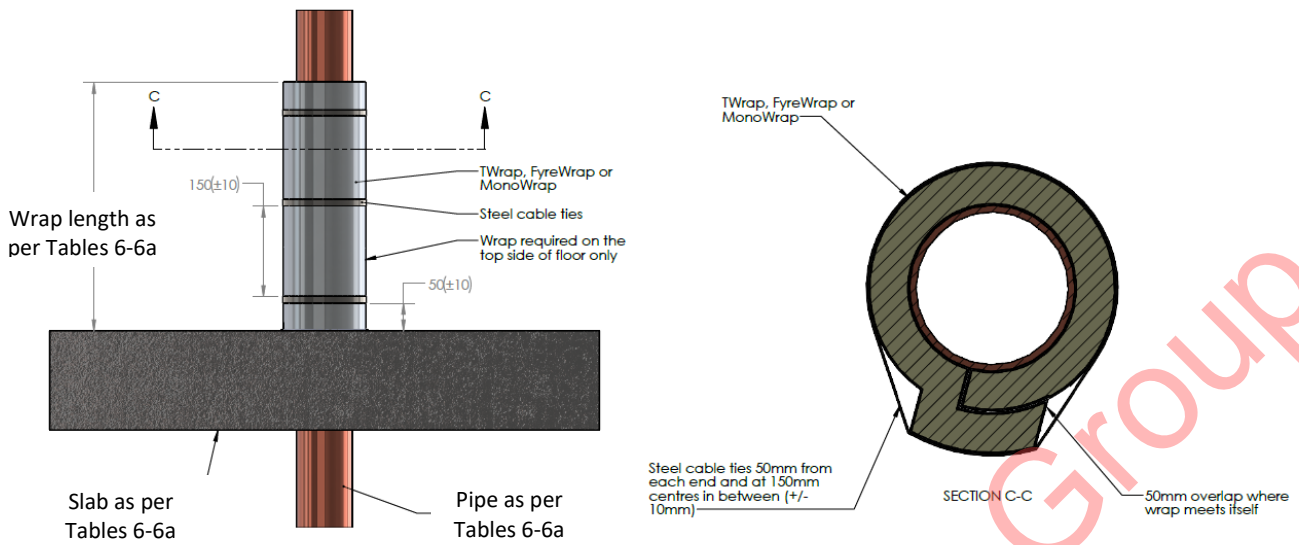
**Table 4: FRL of metal pipes penetrating a 150mm or thicker concrete slab**

Pipe material	Nominal pipe diameter OD	The gap between pipe and slab (mm)	Min. Fyreflex sealant depth (mm)	Min. Fyreflex sealant fillet size on the unexposed side (h x w) (mm)	Figures	FRL
Copper Type B	Up to DN150	10 -20	50	20x50	1, 5a	-/180/-
	DN200	10 -20	115	50x50		-/180/-
Steel Medium Grade	Up to NB100	10 -20	50	20x50		-/180/15
	Up to NB150	10 -20	50	20x50		-/180/-
	NB200 (Max. 5mm wall thickness)	10 -20	115	50x50		-/180/-

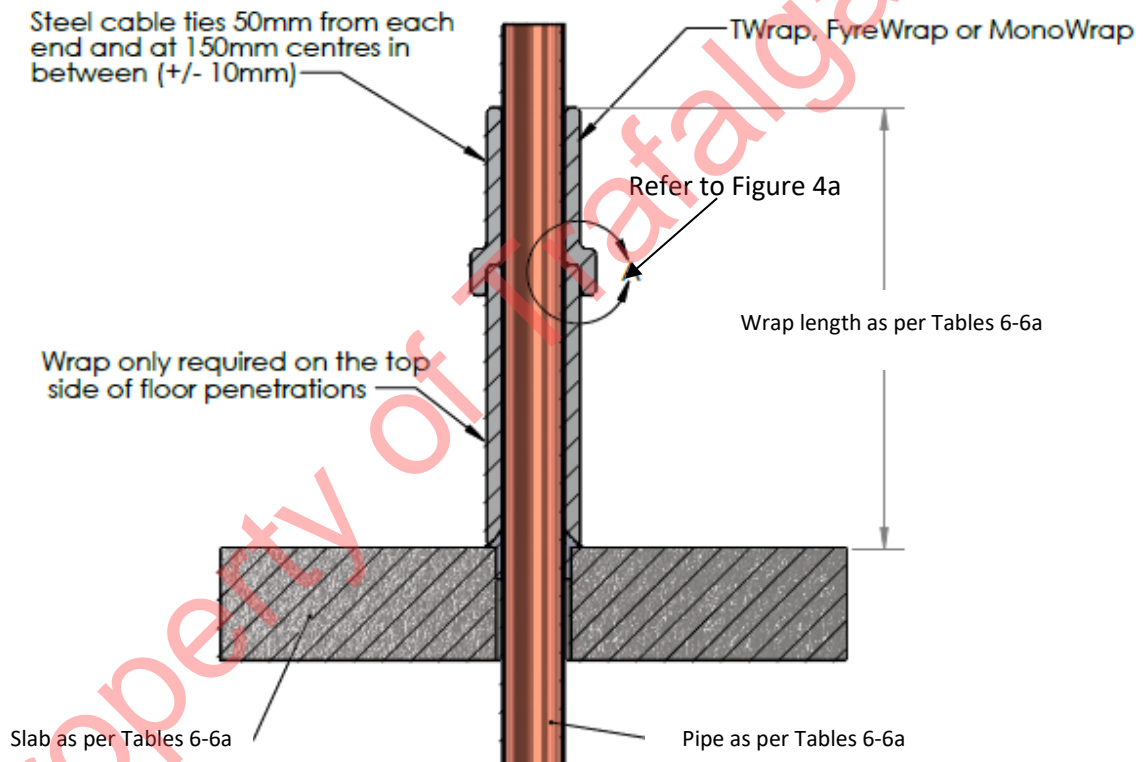
**Table 5: FRL of metal pipes penetrating a 175mm or thicker concrete slab**

Pipe material	Nominal pipe diameter OD	The gap around the pipe (mm))	Min. Fyreflex sealant depth (mm)	Min. Fyreflex sealant fillet size on the unexposed side (h x w) (mm)	Figures	FRL
Steel Medium Grade	Up to NB100	10 -20	50	20x50	1, 5a	-/240/15
	Up to NB150	10 -20	115	50x50		-/240/-

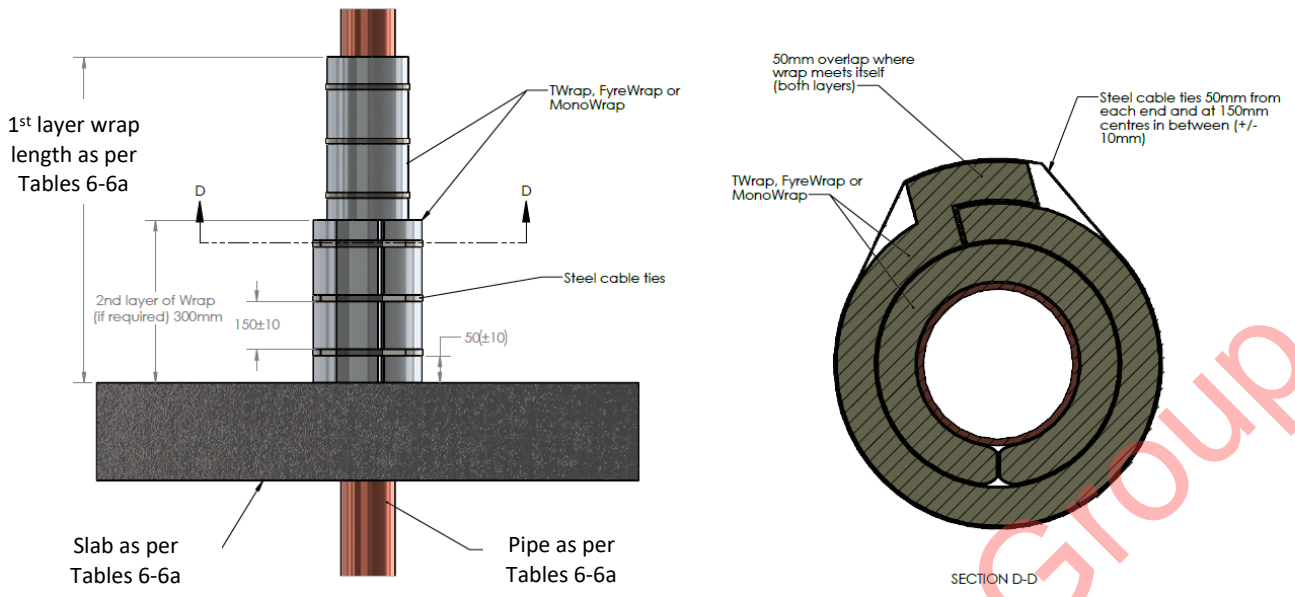
## 5.2 Metal pipes penetrating floors - protected with Twrap, Monowrap or Fyrewrap



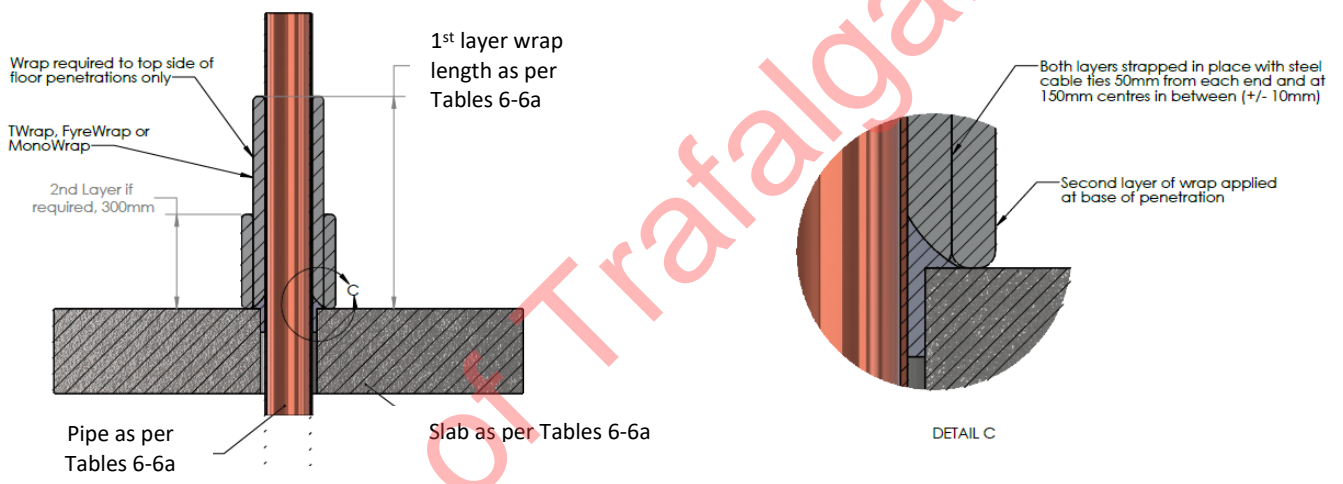
**Figure 2: Wrap overlap and cable tie detail for metal pipes in slabs**



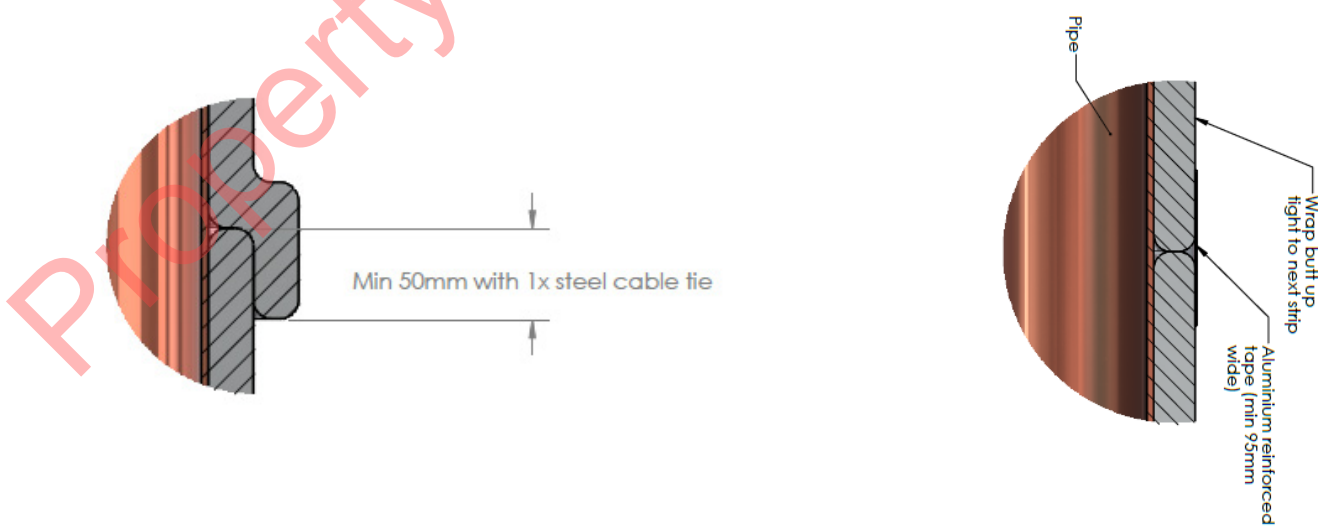
**Figure 3: Single layer wrap detail for metal pipes in slabs**



**Figure 3a: Wrap overlap and cable tie detail for metal pipes in slabs**



**Figure 4: Double layer wrap detail for metal pipes in slabs**



**Figure 4a: Various wrap joint options**

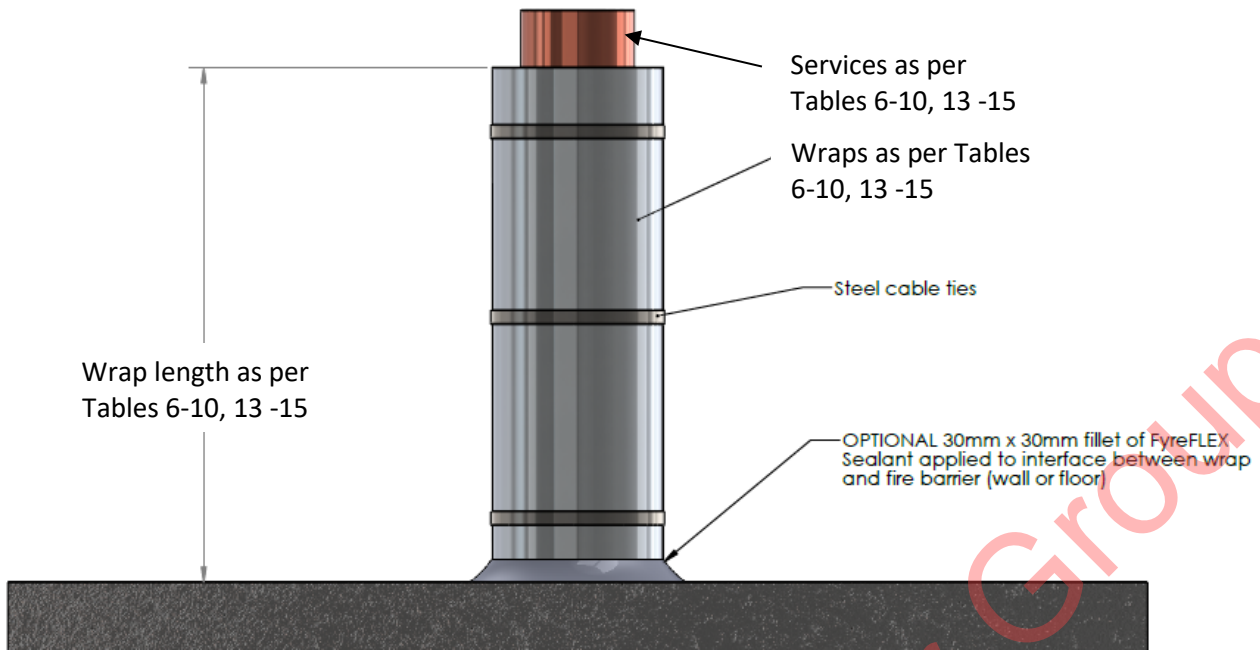


Figure 5: Optional additional fillet of sealant on top of wrap – general detail

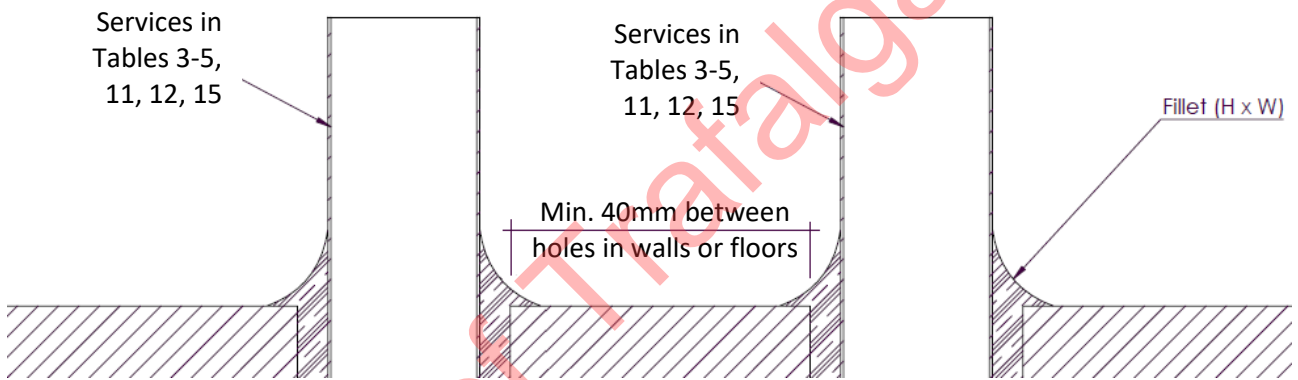


Figure 5a: Separation between metal pipes in walls or floors with no wrap - general detail

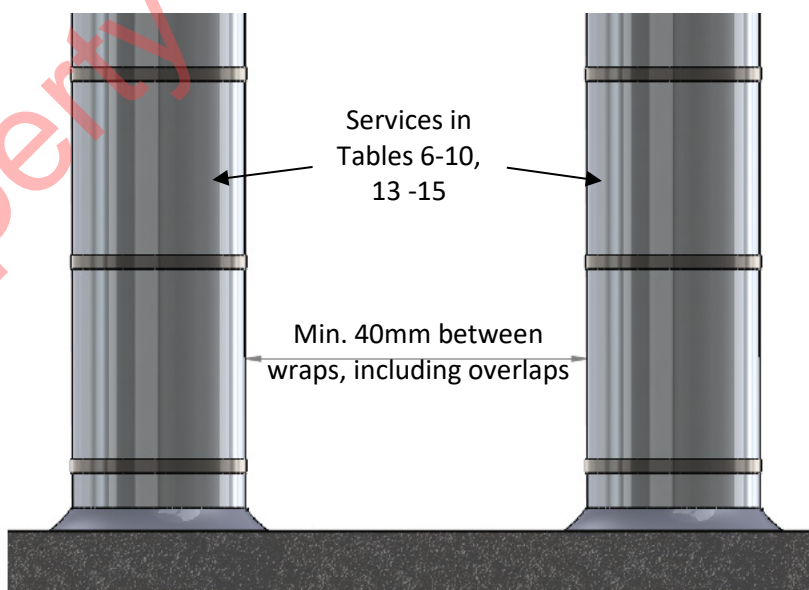


Figure 5b: Separation between wrapped metal pipes in walls or floors - general detail

**Table 6: ≥ 120 minute applications for metal pipe penetrating concrete floors.**

Pipe material	Nominal pipe diameter OD	The gap around the pipe (mm)	Min. Fyreflex sealant depth (mm)	Min. Fyreflex sealant fillet size (h x w) (mm)	Min. 1 <sup>st</sup> and (2 <sup>nd</sup> ) Twrap, Monowrap or Fyrewrap length (mm) on top of the slab	Min. slab thickness (mm)	Figures	FRL
Copper Type B	Up to DN50	10 -20	50	30 x 30	300	175	1 – 5, 5b	-/120/120
	Up to DN100	10 -20	60	30 x 30	750	120		-/120/120
		10 -20	60	30 x 30	600	150		-/120/120
		10 -20	60	30 x 30	800 (300)	175		-/180/180 (Twrap and Fyrewrap only)
	Up to DN150	10 -20	50	30 x 30	850	175		-/120/120
Steel Medium Grade	Up to NB 50	10 -20	50	30 x 30	300	175		-/120/120
	Up to NB100	10 -20	60	30 x 30	750	120		-/120/120
		10 - 20	60	40 x 40	450 (with Unistrut pipe-clamp system)	150		-/120/120
		10 -20	60	40 x 40	450 (without Unistrut)	120		-/120/120
		10 -20	60	40 x 40	450 (without Unistrut)	175		-/180/180 (Twrap and Fyrewrap only)
	Up to NB150	10 -20	50	30 x 30	600	175	-/240/120	
		10 -20	50	30 x 30	600 (300)	175	-/240/180 (Twrap and Fyrewrap only)	

**Table 6a: ≥ 120 minute applications for stainless-steel pipes penetrating concrete floors.**

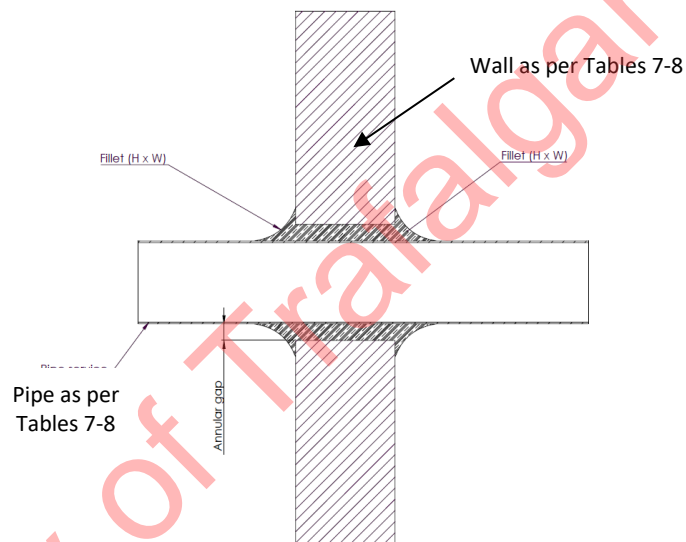
Stainless-steel pipe	The gap around the pipe (mm)	Min. Fyreflex sealant depth (mm)	Min. Fyreflex sealant fillet size (h x w) (mm)	Min. Twrap, Mono-wrap or Fyrewrap length above the slab (mm)	Min. Twrap, Fyrewrap length above the slab (mm)	Min. slab thickness (mm)	Figures	FRL
Up to 54mm OD and a minimum 1.5mm wall thickness	10-20	60	30 x 30	300	NA	120	1 – 5, 5b	-/90/90
				450	NA			-/120/120
				NA	300	150		-/180/180
NA				300	175	-/240/240 (Twrap only)		
Up to 170mm OD and a minimum 1.5mm wall thickness				600	NA	150		-/90/90
				2 x 800	NA	120		-/120/120
				800(300)	NA	150		-/120/120
				NA	2 x 800	150		-/180/180
	NA	2 x 800	175	-/240/240 (Twrap only)				



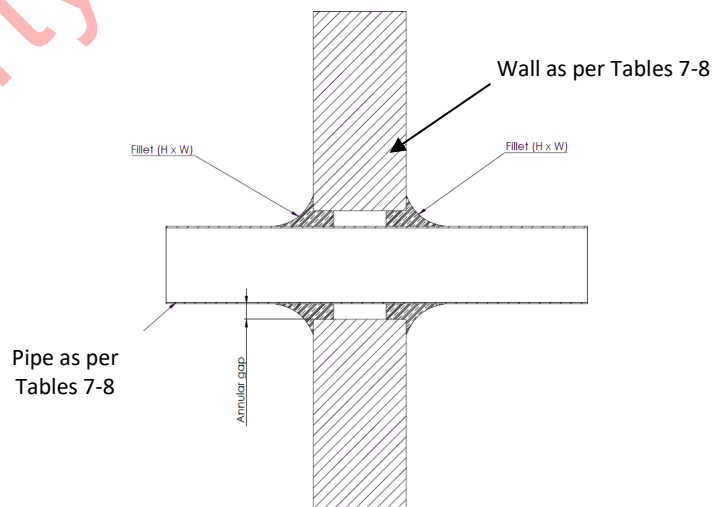
**Table 6b: 90-minute applications for metal pipe penetrating concrete floors.**

Pipe material	Nominal pipe diameter OD	The gap around the pipe (mm)	Min. Fyreflex sealant depth (mm)	Min. Fyreflex sealant fillet size (h x w) (mm)	Min. Twrap, Monowrap or Fyrewrap length on top of the slab (mm)	Min. slab thickness (mm)	Figures	FRL
Copper Type B	Up to DN50	10 -20	60	30 x 30	300	≥120	1 – 5, 5b	-/90/90
	Up to DN65				450			-/90/90
	Up to DN100				600			-/90/90
	Up to DN150				850			-/90/90
Steel Medium Grade	Up to NB 50				300			-/90/90
	Up to NB150				600			-/90/90

### 5.3 Metal pipes penetrating walls - protected with Twrap or Fyrewrap

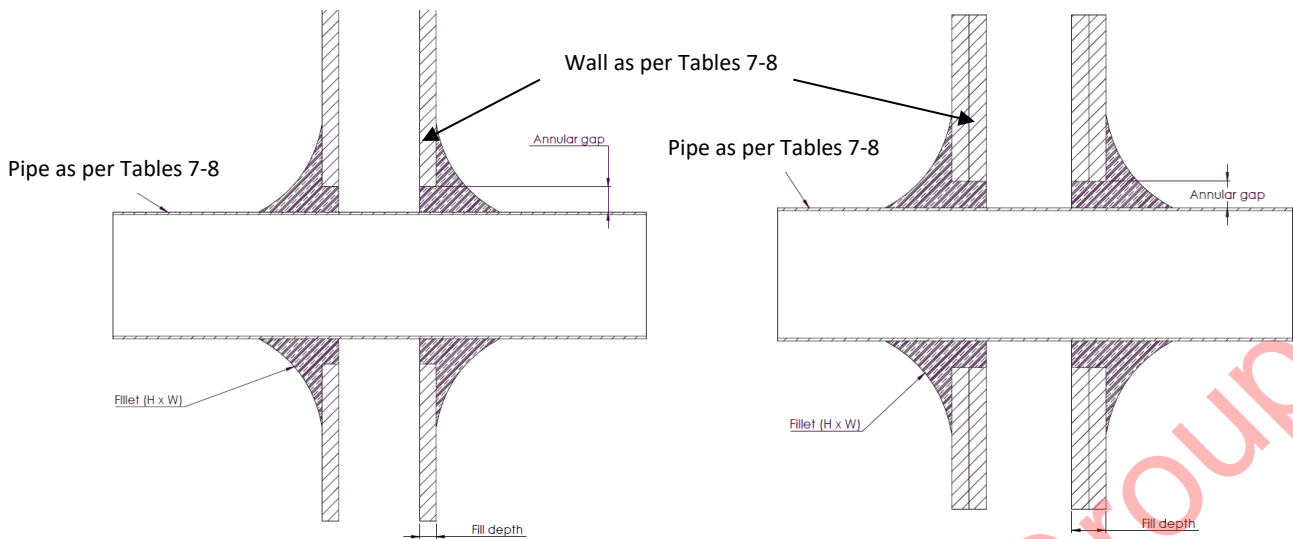


**Figure 6: Sealant detail for pipe in Hebel/Speedpanel walls – full depth sealant**

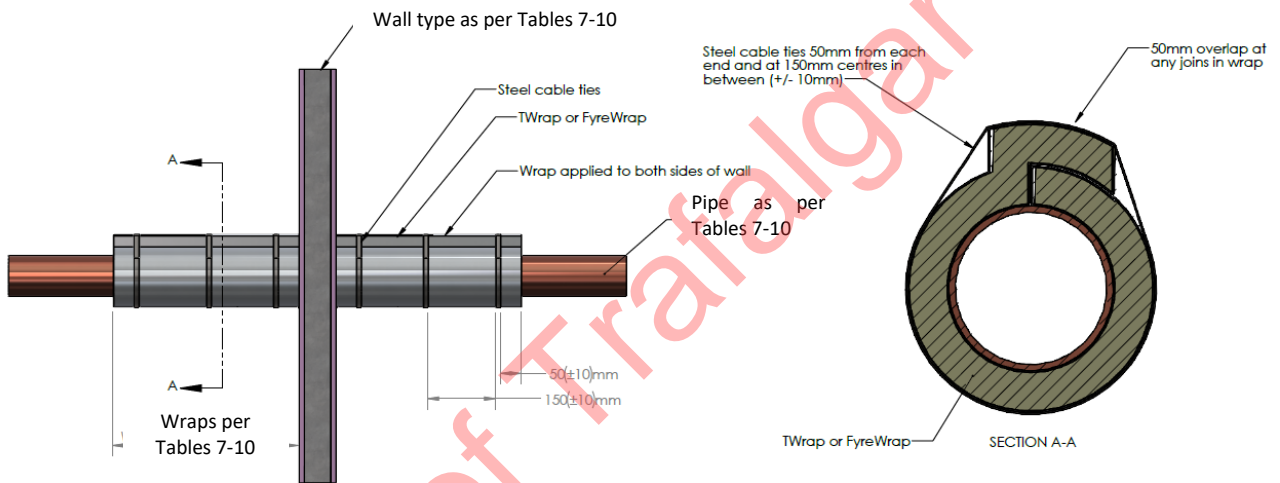


**Figure 7: Sealant detail for pipe in masonry/concrete walls – partially depth sealant**

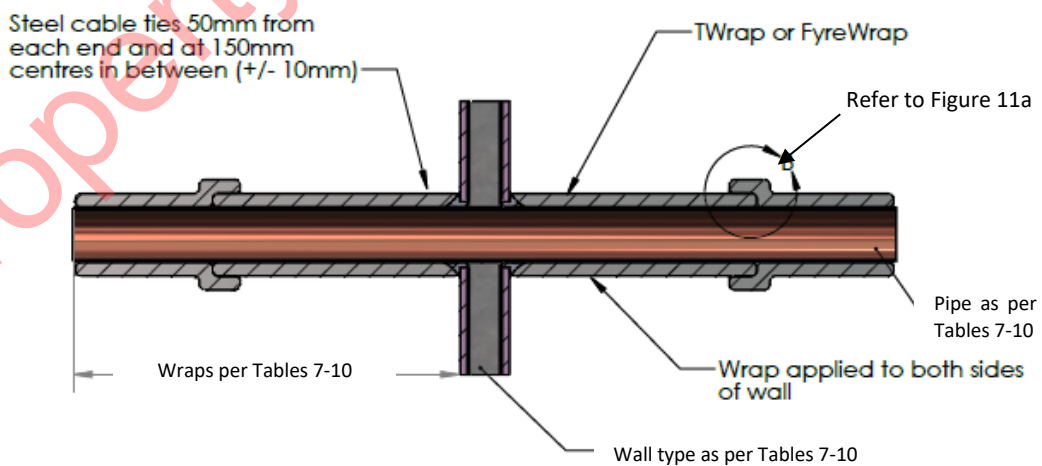




**Figure 8: Sealant detail for pipe in plasterboard lined stud walls– sealant to the full depth of lining**

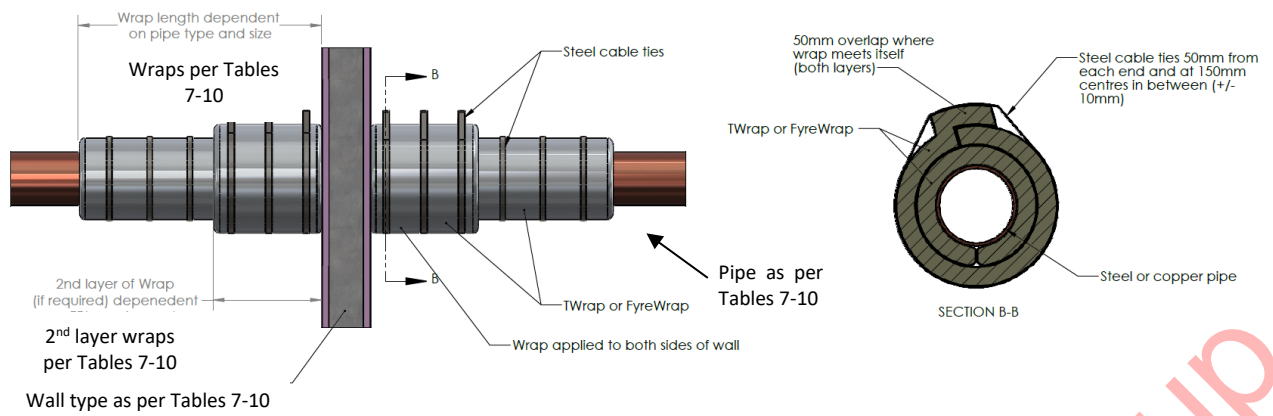


**Figure 9: Single layer wrap overlap and cable tie detail for metal pipes in walls**

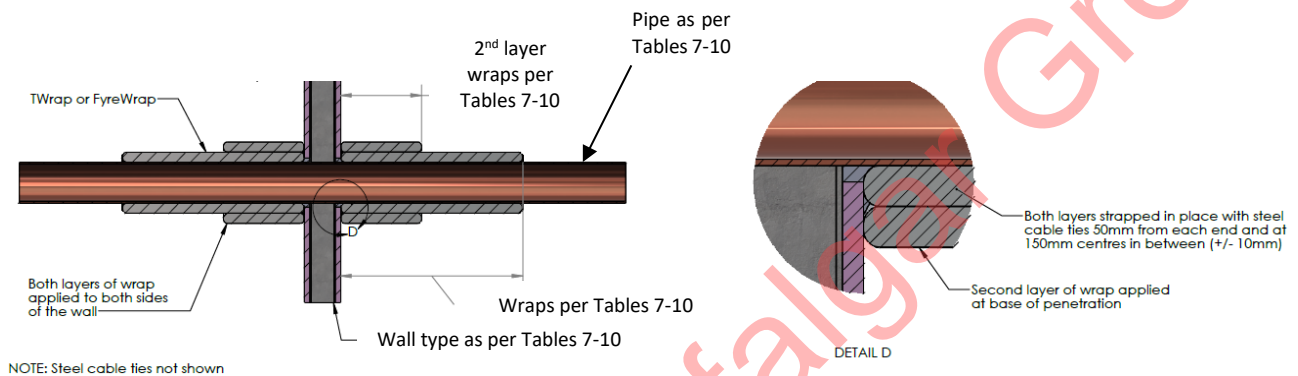


NOTE: Steel cable ties not shown

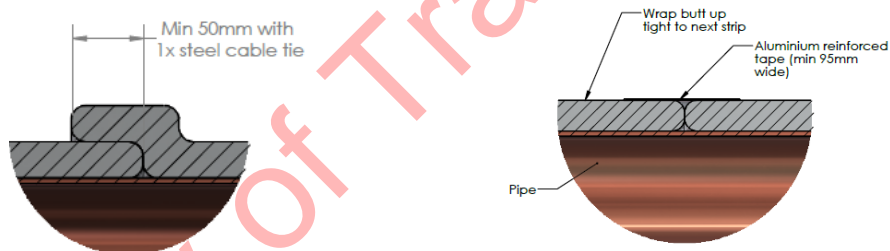
**Figure 10: Single layer wrap detail for metal pipes in slabs**



**Figure 10a: Double layer wrap overlap and cable tie detail for metal pipes in walls**



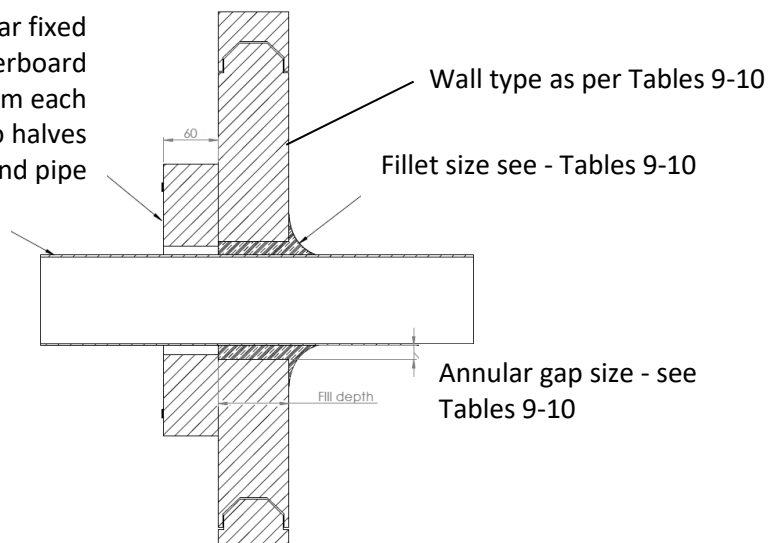
**Figure 11: Double layer wrap detail for metal pipes in slabs**



**Figure 11a: Various wrap joint options**

100 x 100 x 60mm Maxilite collar fixed with minimum 10gx100mm plasterboard screws. Screw fixings 25mm from each corner. Maxilite may be cut into halves and retrofit around pipe

Pipe as per Tables 9 -10



**Figure 12: Typical detail of 60mm thick Maxilite collar around services**

**Table 7: FRL of copper pipe penetrations within various masonry/concrete and plasterboard lined stud walls**

Type B copper pipes	Twrap or Fyrewrap length on each side of the wall	Wall Construction	The gap between the pipe and the wall opening	Min. Fyreflex sealant and other protections at penetration	Min. Fyreflex fillet size (mm)	Figures	FRL							
Up to DN20	300mm	1 x 13mm Single-layer plasterboard walls (min. 90mm thick) Tested or assessed FRL of -/60/60. Or masonry/concrete walls (min. 90mm thick) in accordance with AS 3700 -2018 and AS 3600 -2018	≤10mm	Fyreflex to the full depth of the plasterboard or min. 13mm depth on each side	50 x 50		-/60/60							
DN25														
DN32														
DN40														
DN50														
DN65	450mm													
DN80														
DN100														
Up to DN20								300mm	1 x 16mm single layer plasterboard walls (min. 96mm thick) Tested or assessed FRL of -/90/90. Or masonry/concrete walls (min. 110mm thick) in accordance with AS 3700 -2018 and AS 3600 -2018	≤10mm	Fyreflex to the full depth of the plasterboard or min. 16mm depth on each side	50 x 50	5, 5b, 7-11a	-/90/90
DN25														
DN32														
DN40														
DN50														
DN65	600mm													
DN80														
DN100														
Up to DN20	300mm	2 x 13 or 16mm plasterboard walls (min. 116mm thick) Tested or assessed FRL of -/120/120. Or masonry/concrete walls (min. 130mm thick) in accordance with AS 3700 -2018 and AS 3600 -2018	≤10mm	Fyreflex to the full depth of plasterboard/ or min. 26mm depth on each side	15 x 15		-/120/120							
DN25														
DN32														
DN40														
DN50														
DN65								600mm						
DN80														
DN100														
DN150	1100mm + 2nd layer of 300mm													
150mm x 2.03mm	1500mm + 2nd layer of 300mm							Masonry/concrete walls (min. 180mm thick) in accordance with AS 3700 -2018 and AS 3600 -2018	≤10mm	Fyreflex to min. 26mm depth on each side	50 x 50		-/240/240	
Up to DN20	300mm	Corex wall constructions (2x20mm Corex boards on min. 64mm thick steel stud) tested or assessed FRL of -/90/90	≤10mm	Fyreflex to the full depth of the Corex wall	15 x 15	5, 5b, 6, 9-10, 11a	-/90/90							
DN25														
DN32														
DN40														
DN50														
DN65	600mm													
DN80														
DN100														

Type B copper pipes	Twrap or Firewrap length on each side of the wall	Wall Construction	The gap between the pipe and the wall opening	Min. Fyreflex sealant and other protections at penetration	Min. Fyreflex fillet size (mm)	Figures	FRL
Up to DN20	600mm	Corex wall constructions (2x25mm Corex boards on min. 64mm thick steel stud) tested or assessed FRL of -/120/120	≤10mm	Fyreflex to the full depth of the Corex wall	15 x 15	5, 5b, 6, 9-10, 11a	-/120/120
DN25							
DN32							
DN40							
DN50							
DN65	600mm + 2nd layer of 300mm						
DN80							
DN100							

**Table 8: FRL of steel pipes penetrations within masonry/concrete and plasterboard lined stud walls**

Medium grade Steel pipes	Twrap or Firewrap length on each side of the wall	Wall Construction	The gap between the pipe and the wall opening	Min. Fyreflex sealant and other protections at penetration	Min. Fyreflex fillet size (mm)	Figures	FRL
Up to NB25	300mm	1 x 13mm Single-layer plasterboard walls (min. 90mm thick) Tested or assessed FRL of -/60/60. Or masonry/concrete walls (min. 90mm thick) in accordance with AS 3700 -2018 and AS 3600 -2018	≤10mm	Fyreflex to the full depth of the plasterboard or min. 13mm depth on each side	50 x 50	5, 5b, 7-11a	-/60/60
NB32							
NB40							
NB50							
NB65	400mm						
NB80							
NB100							
Up to NB25	300mm	1 x 16mm single layer plasterboard walls (min. 96mm thick) Tested or assessed FRL of -/90/90 Or masonry/concrete walls (min. 110mm thick) in accordance with AS 3700 -2018 and AS 3600 -2018	≤10mm	Fyreflex to the full depth of the plasterboard or min. 16mm depth on each side	50 x 50	5, 5b, 7-11a	-/90/90
NB32							
NB40							
NB50							
NB65	400mm						
NB80							
NB100							
Up to NB25	300mm	2 x 13 or 16mm plasterboard walls (min. 116mm thick) Tested or assessed FRL of -/120/120 Or masonry/concrete walls (min. 130mm thick) in accordance with AS 3700 -2018 and AS 3600 -2018	≤10mm	Fyreflex to the full depth of the plasterboard or min. 26mm depth on each side	15 x 15	5, 5b, 7-11a	-/120/120
NB32							
NB40							
NB50							
NB65	400mm						
NB80							
NB100							
NB150	600mm						

Medium grade Steel pipes	Twrap or Fyrewrap length on each side of the wall	Wall Construction	The gap between the pipe and the wall opening	Min. Fyreflex sealant and other protections at penetration	Min. Fyreflex fillet size (mm)	Figures	FRL
NB150	1500mm + 2nd layer of 300mm Twrap	Masonry/concrete walls (min. 180mm thick) in accordance with AS 3700 - 2018 and AS 3600 -2018	≤10mm	Fyreflex to min. 26mm depth on each side	50 x 50	5, 5b, 7, 9 - 11a	-/240/240
Up to NB25 NB32 NB40 NB50 NB65 NB80 NB100	300mm     600mm	Corex wall constructions (2x20mm Corex boards on min. 64mm thick steel stud) tested or assessed FRL of - /90/90	≤10mm	Fyreflex to the full depth of the Corex wall	15 x 15	5, 5b, 6, 9-10, 11a	-/90/90
Up to NB25 NB32 NB40 NB50 NB65 NB80 NB100	600mm	Corex wall constructions (2x25mm Corex boards on min. 64mm thick steel stud) tested or assessed FRL of - /120/120	≤10mm	Fyreflex to the full depth of the Corex wall	15 x 15	5, 5b, 6, 9-10, 11a	-/120/120

**Table 9: FRL of copper pipe penetrations within various panel walls**

Type B copper pipes	Twrap or Fyrewrap length on each side of the wall	Wall Construction	The gap between pipe and the wall opening	Fyreflex sealant and other protections at penetration	Min. Fyreflex fillet size (mm)	Figures	FRL
Up to DN20 DN25 DN32 DN40 DN50 DN65 DN80 DN100 DN150	300mm     600mm  1050mm	Min. 75mm single mesh reinforced AAC panel walls tested or assessed FRL of - /90/90	≤10mm	Fyreflex to the full depth of the AAC panel	15 x 15	5, 5b, 6, 9-11a	-/90/90
Up to DN20 DN25 DN32 DN40 DN50	350mm   300mm	Min. 75mm double caged reinforced AAC panel walls tested or assessed FRL of - /120/120	≤10mm	Fyreflex to the full depth of the AAC panel  A layer of 100mm width x 60mm thick Maxilite collar around penetration on one side of the barrier Fyreflex to the full depth of the AAC panel	15 x 15	5, 5b, 6, 9-11a  5, 5b, 6, 9-12	-/120/120

Type B copper pipes	Twrap or Fyrewrap length on each side of the wall	Wall Construction	The gap between pipe and the wall opening	Fyreflex sealant and other protections at penetration	Min. Fyreflex fillet size (mm)	Figures	FRL									
DN65	600mm	Min. 75mm double caged reinforced AAC panel walls tested or assessed FRL of -/120/120	≤10mm	A layer of 100mm width x 60mm thick Maxilite collar around penetration on one side of the barrier Fyreflex to the full depth of the AAC panel	15 x 15	5, 5b, 6, 9-12	-/120/120									
DN80																
DN100																
DN150	1100mm + 2nd layer of 300mm Twrap															
Up to DN20	300mm	Min. 78mm Speedpanel wall tested or assessed FRL of -/120/120	≤10mm	A layer of 100mm width x 60mm thick Maxilite collar around penetration on one side of the barrier Fyreflex to the full depth of Speedpanel	30 x30	5, 5b, 6, 9-12	-/120/120									
DN25																
DN32																
DN40																
DN50																
DN65	600mm															
DN80																
DN100																
DN150	1100mm + 2nd layer of 300mm Twrap															
DN150	900mm															

**Table 10: FRL of steel pipes penetrations within panel walls.**

Medium grade Steel pipes	Twrap or Fyrewrap length on each side of wall	Wall construction	The gap between pipe and the wall opening	Fyreflex sealant and other protections at penetration	Min. Fyreflex fillet size (mm)	Figures	FRL						
Up to NB25	300mm	Min. 75mm single mesh reinforced AAC panel walls tested or assessed FRL of -/90/90	≤10mm	Fyreflex to the full depth of the AAC panel	15 x 15	5, 5b, 6, 9-11a	-/90/90						
NB32													
NB40													
NB50													
NB65													
NB80								450mm					
NB100													
NB150	1050mm												
NB40	NA				40 x 40		-/90/60						
Up to NB25	300mm	Min. 75mm double caged reinforced AAC panel walls tested or assessed FRL of -/120/120	≤10mm	Fyreflex to the full depth of the AAC panel	15 x 15	5, 5b, 6, 9-11a	-/120/120						
NB32													
NB40													
NB50													
NB65	450mm						A layer of 100mm width x 60mm thick		5, 5b, 6, 9-12				
NB80													
NB100													
NB100													

Medium grade Steel pipes	Twrap or Fyrewrap length on each side of wall	Wall construction	The gap between pipe and the wall opening	Fyreflex sealant and other protections at penetration	Min. Fyreflex fillet size (mm)	Figures	FRL
NB150	900mm + 2nd layer of 300mm Twrap	Min. 75mm double caged reinforced AAC panel walls tested or assessed FRL of - /120/120	≤10mm	Maxilite collar around penetration on one side of the barrier Fyreflex to the full depth of the AAC panel	15 x 15	5, 5b, 6, 9-12	-/120/120
Up to NB25	300mm	Min. 78mm Speedpanel wall tested or assessed FRL of - /120/120	≤10mm	Fyreflex to the full depth of Speedpanel	30 x 30	5, 5b, 6, 9-11a	-/120/120
NB32							
NB40							
NB50							
NB65	450mm	Min. 78mm Speedpanel wall tested or assessed FRL of - /120/120	≤10mm	A layer of 100mm width x 60mm thick Maxilite collar around penetration on one side of the barrier Fyreflex to the full depth of Speedpanel	30 x 30	5, 5b, 6, 9-12	-/120/90
NB80							
NB100							
NB150	900mm + 2nd layer of 300mm Twrap	Min. 60mm Pronto Panel walls tested or assessed FRL of - /60/60	≤10mm	Fyreflex to the full depth of the panel	40 x 40	5, 5b, 6, 9-11a	-/60/60
NB150	900mm						
NB40	NA	Min. 60mm Pronto Panel walls tested or assessed FRL of - /60/60	≤10mm	Fyreflex to the full depth of the panel	40 x 40	5, 5b, 6, 9-11a	-/60/60

**Table 10a: FRL of stainless-steel pipes penetrations within various walls.**

Stainless-steel pipe	Min. Twrap or Firewrap length on each side of the wall	Wall construction	The gap around the pipe (mm)	Fyreflex sealant and other protections at penetration	Min. Fyreflex sealant fillet size (h x w) (mm)	Figures	FRL
Up to 54mm and a minimum 1.5mm wall thickness	300mm	1 x 13mm Single-layer plasterboard walls (min. 90mm thick) Tested or assessed FRL of -/60/60.	≤10mm	Full depth of plasterboard lining	50 x 50	5, 5b, 8-11a	-/60/60
		1 x 16mm single layer plasterboard walls (min. 96mm thick) Tested or assessed FRL of -/90/90.					-/90/90
		2 x 13 or 16mm plasterboard walls (min. 116mm thick) Tested or assessed FRL of -/120/120					-/120/120
Up to 170mm and a minimum 1.5mm wall thickness	1100mm + 2nd layer of 300mm wrap	2 x 13 or 16mm plasterboard walls (min. 116mm thick) Tested or assessed FRL of -/120/120					-/120/120
Up to 54mm and a minimum 1.5mm wall thickness	300mm	Min. 75mm single mesh reinforced AAC panel walls tested or assessed FRL of -/90/90		Fyreflex to the full depth of the AAC panel			-/90/90
Up to 170mm and a minimum 1.5mm wall thickness	1050mm						
Up to 100mm and a minimum 1.5mm wall thickness	600mm	Corex wall constructions (2x20mm Corex boards on min. 64mm thick steel stud) tested or assessed FRL of -/90/90	≤10mm	A layer of 100mm width x 60mm thick Maxilite Pad or 3 layers of 100mm width x 25mm thick Corex boards Pad around penetration on one side of the barrier  Fyreflex to the full depth of Corex wall	30 x 30	5, 5b, 6, 9-11a	-/90/90



Stainless-steel pipe	Min. Twrap or Fyrewrap length on each side of the wall	Wall construction	The gap around the pipe (mm)	Fyreflex sealant and other protections at penetration	Min. Fyreflex sealant fillet size (h x w) (mm)	Figures	FRL
Up to 54mm and a minimum 1.5mm wall thickness	300mm	Min. 78mm Speedpanel wall tested or assessed FRL of -/120/120		A layer of 100mm width 60mm thick Maxilite collar around penetration on one side of the barrier			-/120/120
Up to 170mm and a minimum 1.5mm wall thickness	1100mm + 2nd layer of 300mm wrap			Fyreflex to the full depth of Speedpanel			
Up to 100mm and a minimum 1.5mm wall thickness	600mm	Corex wall constructions (2x25mm Corex boards on min. 64mm thick steel stud) tested or assessed FRL of -/120/120	≤10mm	A layer of 100mm width x 60mm thick Maxilite Pad or 2 layers of 100mm width x 25mm thick Corex boards Pad around penetration on each side of the barrier  Fyreflex to the full depth of Corex wall	30 x 30	5, 5b, 6, 9-12	-/120/120
Up to 54mm and a minimum 1.5mm wall thickness	450	Min. 120mm concrete wall in accordance with AS 3600 -2018	≤10mm	30mm from each side	30 x 30	5, 5b, 7, 9-11a	-/120/120
	300	Min. 150mm concrete wall in accordance with AS 3600 -2018					-/180/180
		Min. 175mm concrete wall in accordance with AS 3600 -2018					-/240/240 (Twrap only)
Up to 170mm and a minimum 1.5mm wall thickness	2 x 800	Min. 120mm concrete wall in accordance with AS 3600 -2018					-/120/120
		Min. 150mm concrete wall in accordance with AS 3600 -2018					-/180/180
		Min. 175mm concrete wall in accordance with AS 3600 -2018					-/240/240 (Twrap only)

Stainless-steel pipe	Min. Twrap or Fyrewrap length on each side of the wall	Wall construction	The gap around the pipe (mm)	Fyreflex sealant and other protections at penetration	Min. Fyreflex sealant fillet size (h x w) (mm)	Figures	FRL
Up to 54mm and a minimum 1.5mm wall thickness	450	Min. 130mm concrete wall in accordance with AS 3700 -2018	≤10mm	30mm from each side	30 x 30	5, 5b, 7, 9-11a	-/120/120
	300	Min. 160mm concrete wall in accordance with AS 3700 -2018					-/180/180
		Min. 180mm concrete wall in accordance with AS 3700 -2018					-/240/240
Up to 170mm and a minimum 1.5mm wall thickness	2 x 800	Min. 130mm concrete wall in accordance with AS 3700 -2018					-/120/120
		Min. 160mm concrete wall in accordance with AS 3700 -2018					-/180/180
		Min. 180mm concrete wall in accordance with AS 3700 -2018					-/240/240 (Twrap only)

## 5.4 Cable penetrating floors –cable tray can be discontinuous when present with no wraps

**Table 11: FRL of cable penetrations of a 120mm thick concrete slab.**

Cable Service	The gap around cables (mm)	Min. Fyreflex sealant depth (mm)	Min. Fyreflex sealant fillet size (h x w) (mm)	Figures	FRL
46mm Dia. power cable 16mm Dia. 3-core plus power cable 6 NO. 50 pair telecommunications cable in 110mm dia. hole	10-32	100	50 x 50 Unexposed side	1, 5a	-/120/90
2 x TPS power cable	10 -15	60	30 x 30 Exposed side		-/120/60
1 x 38mm dia. 3C + E power cable with PVC insulation and sheathing	≤ 6	75	50 x 50 Unexposed side		-/120/-
6 x 4 bundle of 100 strand Telecom cables, 15mm Dia. with PVC sheathing and insulation	≤ 6	75	50 x 50 Unexposed side		-/120/-
2 of the copper busbar 50 x 10mm spaced 10 mm apart	≤ 20	30	20 x 50 Unexposed side		-/120/-
150mm Tray with 1 x 38mm OD 3C+E PVC sheathed and insulated, 4 x 20mm OD single core with double PVC sheathing	≤ 6	75	50 x 50 Unexposed side		-/120/-
380mm Tray with 1x 46mm OD single-core power 1x 29mm OD 3C+E power cable 3 x 16mm OD 3C+E power cables 6 x 100 strand telecom cables, 15mm dia. with PVC sheathed and insulated	≤ 6	75	50 x 50 Unexposed side	1, 5a	-/120/-
Up to 20 x 6mm OD CAT6	≤ 20	65	30 x 30 Unexposed side		-/120/120
Up to 20 x 6mm OD Firesense 2.5mm <sup>2</sup> cables	≤ 20	70	40 x 40 Unexposed side		-/120/120
10 x 6mm OD CAT6 10 x 6mm OD Firesense 2.5mm <sup>2</sup> cables 10 x 10 x 4mm TPS cables	≤ 20	70	40 x 40 Unexposed side		-/120/120

**Table 12: FRL of cable penetrations of a 175mm thick concrete slab.**

Cable Service	The gap around cables (mm)	Min. Fyreflex sealant depth (mm)	Min. Fyreflex sealant fillet size on the unexposed side (h x w) (mm)	Figures	FRL
46mm Dia. power cable 16mm Dia. 3-core plus power cable 6 NO. 50 pair telecommunications cable in 110mm dia. hole	10-32	100	50 x 50	1, 5a	-/240/90
2 x TPS power cable	10 -15	60	30 x 30		-/240/60

5.5 Cable penetrating floors –cable tray shall be continuous when present and protected with wrap

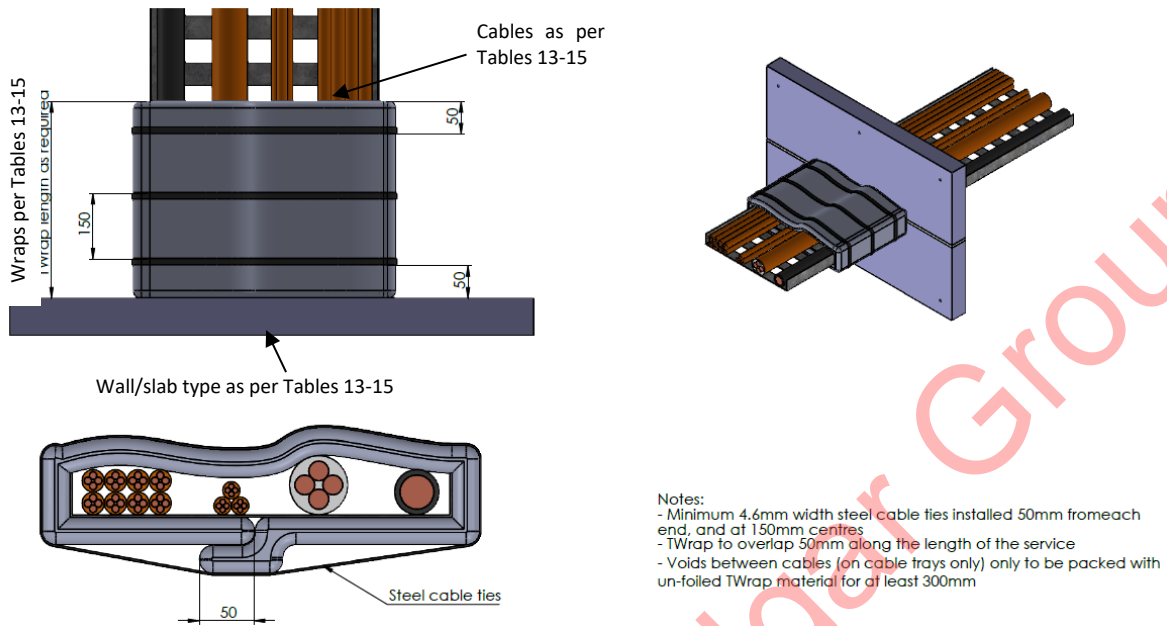


Figure 13: Generic detail of a single length of Twrap detail around cable services

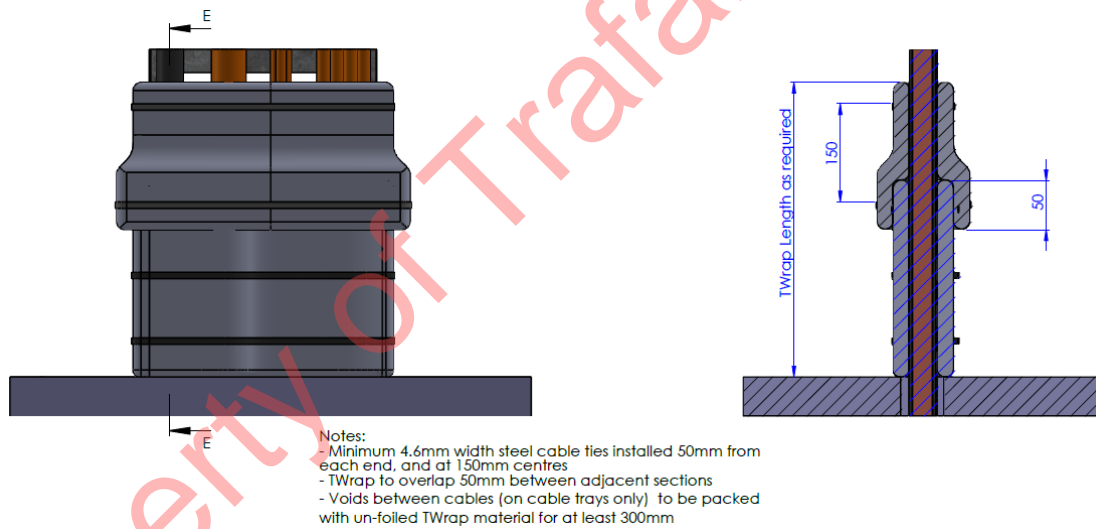


Figure 14: Generic detail of multi-length of Twrap detail around services

**Table 13: FRL of cable services penetrating a min. 120mm thick concrete slab.**

Cable Service	The gap around cables (mm)	Min. Fyreflex sealant depth (mm)	Min. wrap length on top of the slab (mm)	Min. Fyreflex sealant fillet size (h x w) (mm)	Figures	FRL
A 315mm x 50mm cable tray with Appendix A D1 cables: 1 x 49mm OD 3C+E cable 185mm <sup>2</sup> 1 x 41mm OD single cable 630mm <sup>2</sup> 3 x 15mm OD 3C+E cable 6mm <sup>2</sup> 8 x 20mm OD 3C+E cable 16mm <sup>2</sup>	5-30	60	450mm Twrap, Monowrap or Fyrewrap top side of the slab and cable tray packed with loose TWrap or Fyrewrap infill material	50 x 50 Unexposed side	1, 5, 5b,13, 14	-/120/120
A 300mm x 47mm cable tray with Appendix A D1 cables: 1 x 50mm OD 3C+E cable 185mm <sup>2</sup> 1 x 43mm OD single cable 630mm <sup>2</sup> 3 x 15mm OD 3C+E cable 6mm <sup>2</sup> 8 x 20mm OD 3C+E cable 16mm <sup>2</sup>	5-30	60	300mm Twrap, Monowrap or Fyrewrap top side of the slab and cable tray packed with loose TWrap or Fyrewrap infill material	50 x 50 Unexposed side		-/90/90

**Table 14: FRL of cable penetrations of min. 175mm concrete floor.**

Cable Service	The gap around cables (mm)	Min. Fyreflex sealant depth into the slab (mm)	Min. wrap length on top of the slab (mm)	Min. Fyreflex sealant fillet size (h x w) (mm)	Figures	FRL
A 315 x 50mm cable tray with Appendix A D1 cables; 1 x 49mm OD 3C+E cable 185mm <sup>2</sup> 1 x 41mm OD single cable 630mm <sup>2</sup> 3 x 15mm OD 3C+E cable 6mm <sup>2</sup> 8 x 20mm OD 3C+E cable 16mm <sup>2</sup>	5-30	60	450mm Twrap or Fyrewrap top side of the slab and cable tray packed with loose TWrap or Fyrewrap infill material	50 x 50 Unexposed side		-/180/180
A 315mm x 50mm cable tray with: 1 x 49mm OD 3C+E cable 185mm <sup>2</sup> 3 x 15mm OD 3C+E cable 6mm <sup>2</sup> 8 x 20mm OD 3C+E cable 16mm <sup>2</sup>	5-30	60	2 layers of 450mm Twrap top side of the slab and the cable tray packed with loose TWrap infill material	50 x 50 Unexposed side	1, 5, 5b,13, 14	-/240/240
			2 layers of 450mm Fyrewrap top side of the slab and the cable tray packed with loose Fyrewrap infill material	50 x 50 Unexposed side		-/240/180

## 5.6 Cable penetrating walls –cable tray shall be continuous when present

**Table 15: FRL of electrical penetrations of various wall types – continuous cable tray.**

Cable Service	The gap around cables (mm)	Min. Fyreflex sealant depth into the barrier	Min. Twrap or Fyrewrap length on each side of the wall	Min. Fyreflex sealant fillet size on each side of the wall (h x w) (mm)	Wall construction	Figures	FRL
300 x 47mm cable tray Appendix A D1 cables:  1 x 45mm OD 1C cable 630mm <sup>2</sup> 1 x 48mm OD 3C+E cable 185mm <sup>2</sup> 3 x 15mm OD 3C+E cable 6mm <sup>2</sup> 8 x 20mm OD 3C+E cable 16mm <sup>2</sup>	≤20mm	30mm each side	300mm and cable tray packed with loose Twrap infill material	50 x 50	75mm double caged Hebel wall system tested or assessed to an FRL of -/120/120	5, 5b,7, 13	-/120/120
					78mm Speedpanel wall systems tested or assessed to an FRL of -/120/120		-/120/120
					Min. 130mm thick masonry wall designed in accordance with AS 3700 for an FRL of -/180/120 or Min. 120mm thick concrete wall designed in accordance with AS 3600 for an FRL of -/180/120		-/180/120
Up to 10 x TPS cables 2.5mm <sup>2</sup> (5.29 x 12.1mm) or up to 10 x CAT 6 cables (5.75mm OD) or up to 6 x Eltech VRF cables (ELT7501P)	≤20mm	26mm each side	300mm	15 x 15	Min. 116mm thick plasterboard wall lined with 2x13mm FR plasterboard tested or assessed to an FRL of -/120/120	5, 5b,8, 13	-/120/120
Up to 8 x 3C+E power cables	≤20mm	26mm each side	300mm	30 x 30			
Up to 3 x 19 mm OD, 3C+E 16mm <sup>2</sup> power cables	≤5mm	13mm each side	None	50 x 50	Min. 90mm thick plasterboard wall lined with 1x13mm FR plasterboard tested or assessed to an FRL of -/60/60	8, 5a	-/60/60
Up to 3 x 19 mm OD, 3C+E 16mm <sup>2</sup> power cables	≤5mm	16mm on each side	300mm		Min. 96mm thick plasterboard wall lined with 1x16mm FR plasterboard tested or assessed to an FRL of -/90/90	5, 5b, 8, 13	-/90/90

Cable Service	The gap around cables (mm)	Min. Fyreflex sealant depth into the barrier	Min. Twrap or Fyrewrap length on each side of the wall	Min. Fyreflex sealant fillet size on each side of the wall (h x w) (mm)	Wall construction	Figures	FRL
Up to 3 x 19 mm OD, 3C+E 16mm <sup>2</sup> power cables	≤20mm	32mm on each side	300mm	50 x 50	Min. 96mm thick plasterboard wall lined with 1x16mm FR plasterboard tested or assessed to an FRL of -/90/90 Additional 100mm x 100mm x 16mm FR plasterboard patch on each side of the wall	5, 5b, 8, 13	-/90/90
Up to 5 x TPS cables 2.5mm <sup>2</sup> or up to 5 x CAT 6 cables or up to 5 x Eltech VRF cables (ELT7501P)	≤5mm	16mm each side	None	30 x 30	Min. 96mm thick plasterboard wall lined with 1x16mm FR plasterboard tested or assessed to an FRL of -/90/90	5a, 8	-/90/90
Up to 4 x CAT6 (6.3mm OD) or up to 4 x TPS cables 2.5mm <sup>2</sup> or up to 4 x Eltech VRF cables (ELT7501P)	≤5mm	15mm each side	None	30 x 30	75mm Single mesh Hebel wall system tested or assessed to an FRL of -/90/90	5a, 7	-/90/90
Up to 3 x 18mm OD 3C+E Power 16mm <sup>2</sup> cable	≤5mm	78mm	300mm	50 x 50	78mm Speedpanel wall system tested or assessed to an FRL of -/120/120	5, 5b, 6, 13	-/120/120
Up to 4 x CAT6 cables 5.75mmOD, or up to 4 x 2C+E Prysmian Cables 2.5mm <sup>2</sup> 6.21mm OD or Up to 4 x Firesense TP cables (5.1mm OD) or up to 4 x Eltech VRF cables (ELT7501P)	≤5mm	78mm	None	50 x 50		5a, 6	-/120/120
Up to 4 x 6mm OD RG-6 Quad shield co-axial cables	≤5mm	26mm each side	None	30 x 30	Min. 90mm thick plasterboard wall lined with 1x13mm FR plasterboard tested or assessed to an FRL of -/60/60 Additional 100mm x 100mm x 13mm FR plasterboard patch on each side of wall	5a, 8	-/60/60

Cable Service	The gap around cables (mm)	Min. Fyreflex sealant depth into the barrier	Min. Twrap or Fyrewrap length on each side of the wall	Min. Fyreflex sealant fillet size on each side of the wall (h x w) (mm)	Wall construction	Figures	FRL
Up to 4 x 6mm OD RG-6 Quad shield co-axial cables	≤5mm	75mm	None	30 x 30	75mm Single mesh Hebel wall system tested or assessed to an FRL of -/90/90	5a, 6	-/90/90
Up to 4 x 6mm OD RG-6 Quad shield co-axial cables	≤5mm	75mm	None	30 x 30	75mm double caged Hebel wall system tested or assessed to an FRL of -/120/120	5a, 6	-/120/120
		78mm	None	30 x 30	78mm Speedpanel wall system tested or assessed to an FRL of -/120/120	5a, 6	
		40mm on each side	None	30 x 30	Min. 130mm thick masonry wall designed in accordance with AS 3700 for an FRL of -/120/120 or Min. 120mm thick concrete wall designed in accordance with AS 3600 for an FRL of -/120/120	5a, 7	
		26mm	300mm	50 x 50	Min. 116mm thick plasterboard wall lined with 2x13mm FR plasterboard tested or assessed to an FRL of -/120/120	5, 5b, 8, 13	
Up to 30 x TPS cables 2.5mm <sup>2</sup> or up to 30 x TPS fire 1.5mm <sup>2</sup> or up to 30 x CAT6 cables	≤5mm	Full depth of the Corex wall	300mm	50 x 50	Corex wall constructions (2x20mm Corex boards on min. 64mm thick steel stud) tested or assessed FRL of -/90/90	5, 5b, 6, 13	-/90/90
					Corex wall constructions (2x25mm Corex boards on min. 64mm thick steel stud) tested or assessed FRL of -/120/120		-/120/120



Cable Service	The gap around cables (mm)	Min. Fyreflex sealant depth into the barrier	Min. Twrap or Fyrewrap length on each side of the wall	Min. Fyreflex sealant fillet size on each side of the wall (h x w) (mm)	Wall construction	Figures	FRL
Up to 8 x 19mm OD, 3C+E 16mm <sup>2</sup> power cables	Full depth of the Corex wal	Full depth of the Corex wal	300mm	50 x 50	Corex wall constructions (2x20mm Corex boards on min. 64mm thick steel stud) tested or assessed FRL of -/90/90	5, 5b, 6, 13	-/90/90
			2 layers of 300mm		Corex wall constructions (2x25mm Corex boards on min. 64mm thick steel stud) tested or assessed FRL of -/120/120		-/120/120
Up to 5 x Eltech VRF cables (ELT7501P)	≤5mm	Full depth of the Corex Wall	300mm	30 x 30	Corex wall constructions (2x20mm Corex boards on min. 64mm thick steel stud) tested or assessed FRL of -/90/90	5, 5b, 6, 13	-/90/90
					Corex wall constructions (2x25mm Corex boards on min. 64mm thick steel stud) tested or assessed FRL of -/120/120		-/120/120

## 6 Direct Field of Application of Results

The results of this assessment apply to penetrations in floors when exposed to fire from below and penetrations in walls when exposed to fire from either side.

## 7 Requirements

It is required the systems described above be fitted to a wall or floor construction that has been tested, assessed or designed to achieve the required FRL.

Any variations concerning size, constructional details, loads, stresses, edge or end conditions that are other than those identified in this report, may invalidate the conclusions drawn in this report.

## 8 Term of Validity

This assessment report will lapse on 30<sup>th</sup> November 2025. Should you wish us to re-examine this report with a view to the possible extension of its term of validity, would you please apply to us three to four months before the date of expiry. This Division reserves the right at any time to amend or withdraw this assessment in the light of new knowledge.

## 9 Limitations

The conclusions of this assessment report may be used to directly assess the fire resistance performance under such conditions, but it should be recognised that a single test method will not provide a full assessment of the fire hazard under all fire conditions.

Because of the nature of fire resistance testing, and the consequent difficulty in quantifying the uncertainty of measurement, it is not possible to provide a stated degree of accuracy. The inherent variability in test procedures, materials and methods of construction, and installation may lead to variations in performance between elements of similar construction.

This assessment report does not provide an endorsement by CSIRO of the actual products supplied to the industry. The referenced assessment can therefore only relate to the actual prototype test specimens, testing conditions and methodology described in the supporting data, and does not imply any performance abilities of constructions of subsequent manufacture.

This assessment is based on information and experience available at the time of preparation. The published procedures for the conduct of tests and the assessment of test results are the subject of constant review and improvement, and it is recommended that this report is reviewed on or, before, the stated expiry date.

The information contained in this assessment report shall not be used for the assessment of variations other than those stated in the conclusions above. The assessment is valid provided no modifications are made to the systems detailed in this report. All details of construction should be consistent with the requirements stated in the relevant test reports and all referenced documents.

# Appendix A Supporting Test Data

## A.1 Fire Research Laboratories Report NI 1089

On 2 March 1989, Fire Research Laboratories conducted a fire test accordance with AS 1530.4-1985 on a 115mm slab mortar penetrated by various penetrations and protected by Fyreflex sealant.

The specimen assembly comprised a 115mm thick lightweight concrete slab, 1900mm long x 900mm wide. Three through holes were cast in the concrete slab having diameters of 160mm, 110mm and 56mm. The 60mm diameter hole was penetrated by a 114mm diameter steel pipe and the 110mm diameter hole was penetrated by a bundle of assorted cables including single-core power cables, three core plus earth power cables and telecommunication cables.

Only specimens B and C are discussed in the report. Their construction and performance are summarized below in A.28 Summary of test data.

## A.2 Fire Research Laboratories Report NI 2689

On the 7 July 1989, Fire Research Laboratories conducted a fire test accordance with AS 1530.4-1985 on a 75mm E core panel penetrated by various penetrations and protected with Fyreflex.

The test construction comprised a lightweight concrete slab approximately 2.9m x 1.9m, 115mm thick with a central opening 2.13m x 1m wide. The opening was penetrated by a variety of services and fire stopped by an E-core floor panel system in combination with Fyreflex sealant and Fyrechoke Type 3 collars. The E-core floor panel system was fitted after the services were positioned in the opening.

Only specimens A, D, F, G, H, J and L are discussed in the report. Their construction and performance are summarized below in A.28 Summary of test data.

## A.3 Fire Research Laboratories Report NI 3089

On the 14 August 1989, Fire Research Laboratories conducted a fire test accordance with AS 1530.4-1985 on 125mm thick Bondek slab penetrated by various penetrations and protected by Fyreset mortar and Fyreflex sealant.

The test construction comprised a 125mm thick concrete slab with steel decking over its soffit with an opening 0.8m long x 1.0m wide. Six services passed through the opening as detailed below. The opening was filled with lightweight Fyreset mortar.

Only specimens A and E are discussed in the report. Their construction and performance are summarized below in A.28 Summary of test data.

## A.4 Applicability of AS 1530.4 – 1985 test data to AS 1530.4 -2014

The referenced fire resistance tests and NI1089, NI2689 and NI3089 were conducted in accordance with AS 1530.4– 1985, which differs from AS 1530.4–2014. These variations and their potential effect on the fire resistance performance of the referenced test specimen are discussed below.

### ***Furnace Temperature Regime***

The specified specimen heating rate in AS 1530.4–1985 is given by:

$$T_t - T_0 = 345_{\log}(8t+1)$$

Where;

$T_t$  = Furnace temperature at time  $t$ , in degrees Celsius.

$T_0$  = Initial furnace temperature, in degrees Celsius, not less than 10°C nor more than 40°C.

$t$  = Time into the test, measured from the ignition of the furnace, in minutes.

The furnace heating regime in fire resistance tests conducted in accordance with AS 1530.4–2014 follows the same trend to that in AS 1530.4–1985.

### ***Furnace Thermocouples***

The furnace thermocouples specified in AS 1530.4-2014 are type K, mineral insulated metal sheathed (MIMS) with a stainless steel sheath having a wire diameter of less than 1.0mm and an overall diameter of 3mm. The measuring junction protrudes a minimum of 25mm from the supporting heat resistant tube.

The furnace thermocouples specified in AS 1530.4-1985 are type K but they can be exposed, substantially enclosed or fully enclosed.

The positioning of furnace thermocouples from the exposed face of the specimen at the start of the fire resistance test was required to be between 75mm and 300mm in AS 1530.4-1985. In AS 1530.4-2014, the distance is required to be 100mm  $\pm$  10mm.

With reference to the construction tested and the position of the thermocouples within the furnace when tested, it is considered that the minor variation in the location of the furnace thermocouples relative to the exposed face of the specimen would not significantly affect the insulation performance of the specimens.

### ***Furnace Pressure***

The furnace pressure required by AS 1530.4-1985 is not nominated, however, the standard required the pressure to be measured at a level of 100mm from the underside of the horizontal specimen.

It is a requirement of AS 1530.4-2014 that for horizontal elements, the furnace shall be operated such that a pressure of 20Pa is established at a position 100 mm below the underside of the test specimen above that of the laboratory atmosphere.

The potential difference in specified furnace pressures between the standards is not expected to be significant, provided the integrity of the specimen is maintained. Furthermore, given that the specified tolerances are +3Pa for 10 minutes of test time, the minor variation in furnace pressure is not expected to have significantly affected the outcome of the referenced fire resistance test.

The specimens referenced in NI1089 and NI2689 maintained integrity for the duration of the test. Therefore, the minor difference in furnace pressure will not affect the outcome of the test result.

The specimen referenced in NI3089 maintained integrity for 228 minutes of the test. Therefore the minor difference in furnace pressure will not affect the outcome of the test result for up to 228 minutes.

### ***Specimen mounting***

The mounting of specimens differs slightly between AS 1530.4-2014 and AS 1530.4-1985.

AS 1530.4-1985 requires penetration services to be mounted such that it protrudes no less than 2000mm away from the furnace and no less than 100mm into the furnace.

AS 1530.4-2014 requires penetration services to be installed so that it projects a minimum of 500 mm on each side of the supporting construction, of which at least 200 mm shall extend beyond the extremities of the penetration sealing system.

The specimens in NI1089 and NI2689 were protruding 2000mm away from the furnace and 500mm into the furnace and had 500mm specimens extension beyond the extremities of the penetration sealing system.

The specimens in NI3089 were protruding 2000mm away from the furnace and 100mm into the furnace and had 100mm specimen extension beyond the extremities of the penetration sealing system.

The AS 1530.4-2014 configuration is more onerous than the AS 1530.4-1985 specification and as such the results are not suitable for the direct assessment of insulation performance and the result shall be examined on a case by case basis.

### ***Specimen Thermocouples***

The specimen thermocouple positions differ slightly between AS 1530.4-2014 and AS 1530.4-1985. The difference would not have affected the outcome of the test if tested in accordance with AS 1530.4-2014.

### ***Integrity Criteria***

The integrity criteria differ slightly between AS 1530.4-2014 and AS 1530.4-1985. For AS 1530.4-2014, the penetration shall be deemed to have failed the integrity when;

- a) Flaming occurs or
- b) when a 6mm x 150mm gap gauge can pass through the specimen.
- c) Failed cotton pad

The integrity criteria for AS 1530.4-1985 deems a penetration to have failed integrity if a crack or fissure opens during the test that allows the passage of hot gases or flames or when flaming occurs at the unexposed face of the specimen for a period exceeding 10 seconds duration.

When tested in NI1089 did have the cotton pad was available, however, it was not needed as no gap formed for the duration of the test. When tested in NI2689 cracks and fissures did not form for up to 120 minutes. Therefore, the cotton pad criteria, therefore, do not apply for up to 120 minutes. When tested in NI3589 cracks and fissures did not form for up to 228 minutes. Therefore, the cotton pad criteria do not apply for up to 228 minutes.

### ***Insulation Criteria***

The insulation criteria differ slightly between AS 1530.4-2014 and AS 1530.4-1985. For AS 1530.4-2014, the penetration shall be deemed to have failed the insulation when;

- a) The thermocouple located on the specimen or the separating element exceeds the initial temperature by more than 180° K.
- b) For cable penetrations, if during the test, fissuring of the insulating materials occurs, exposing conductors before the temperature rise measured on the cables has exceeded 180° K and the temperature of the exposed conductors shall be measured by a roving thermocouple, provided that the fissure is wider than 12 mm. This temperature shall be used in the determination of the insulation rating.

AS 1530.4-1985 deems the penetration to have failed insulation when the thermocouple located on the specimen or the separating element exceeds the initial temperature by more than 180° K or reaches a temperature higher than 220°C.

The insulation performance of the cables in test NI1089 was 110 minutes, well before exposure of conductors was noted at 115 minutes and therefore a roving thermocouple would not be required by AS 1530.4-2014. The difference would not have affected the outcome of the test if tested in accordance with AS 1530.4-2014.

#### **Application of Test Data**

On the basis of the discussion above, it is concluded that the results obtained from the referenced fire resistance tests conducted in accordance with AS 1530.4-1985 can be applied to an assessment of the integrity performance and on a case by case basis insulation performance of metal pipes and cable penetration on the referenced tests if tested in accordance with AS 1530.4-2014.

### **A.5 CSIRO Report FSP 0768**

On the 8 June 2016, CSIRO North Ryde conducted a fire test in accordance with AS 1530.4-1997 on 80mm thick Fyreset mortar and 5mm Hardiflex penetrated by various penetrations and protected by Fyreflex sealant.

The specimen comprised an 1150 mm x 1150 mm x 120 mm thick reinforced concrete slab with a 600 mm x 600 mm opening, penetrated by two copper pipes and one cable tray. The opening was fire stopped with 80 mm of Fyreset mortar and penetrations sealed with Tyco Fyreflex Sealant.

Penetrations were passed through cement board formwork located underneath the square opening in the centre of the concrete slab. Cables were passed through the formwork and uPVC formers were used to create the holes for the pipes. Fyreset Mortar was poured into the opening to a depth of 80 mm and tightly packed around the cables. Once the mortar was cured, uPVC pipe formers were removed, and pipes were passed through the slab and sealed with Fyreflex Sealant.

Only specimens A and B are discussed in the report. Its construction and performance are summarized below in A.28 Summary of test data.

### **A.6 Applicability of AS 1530.4 – 1997 test data to AS 1530.4 -2014**

The referenced fire resistance test and FSP 0768 was conducted in accordance with AS 1530.4– 1997, which differs from AS 1530.4–2014. These variations and their potential effect on the fire resistance performance of the referenced test specimen are discussed below.

#### **Furnace Temperature Regime**

The specified specimen heating rate in AS 1530.4–1997 is given by:

$$T_t - T_0 = 345_{\log}(8t+1)$$

Where;

$T_t$  = Furnace temperature at time  $t$ , in degrees Celsius.

$T_0$  = Initial furnace temperature, in degrees Celsius, not less than 10°C nor more than 40°C.

$t$  = Time into the test, measured from the ignition of the furnace, in minutes.

The furnace heating regime in fire resistance tests conducted in accordance with AS 1530.4–2014 follows the same trend to that in AS 1530.4–1997.

#### **Furnace Thermocouples**

The furnace thermocouples specified in AS 1530.4-2014 are type K, mineral insulated metal sheathed (MIMS) with a stainless steel sheath having a wire diameter of less than 1.0mm and an overall diameter of 3mm. The measuring junction protrudes a minimum of 25mm from the supporting heat resistant tube.

The furnace thermocouples specified in AS 1530.4–1997 are the same as that of AS 1530.4-2014.

### ***Furnace Pressure***

It is a requirement of AS 1530.4-2014 that for horizontal elements, the furnace shall be operated such that a pressure of 20Pa is established at a position 100 mm below the underside of the test specimen above that of the laboratory atmosphere. It is a requirement of AS 1530.4-1997 is the same.

### ***Specimen mounting***

The mounting of specimens differs slightly between AS 1530.4-2014 and AS 1530.4-1997.

AS 1530.4-1997 requires cable and metal pipe penetration services to be mounted such that it protrudes no less than 500mm away from the furnace and no less than 100mm into the furnace.

AS 1530.4-2014 requires penetration services to be installed so that it projects a minimum of 500 mm on each side of the supporting construction, of which at least 200 mm shall extend beyond the extremities of the penetration sealing system.

The specimens in FSP 0768 were protruding 500mm away from the furnace and 100mm into the furnace and had 100mm specimen extension beyond the extremities of the penetration sealing system.

The AS 1530.4-2014 configuration is more onerous than the AS 1530.4-1997 specification and as such the results are not suitable for the direct assessment of insulation performance and the result shall be examined on a case by case basis.

### ***Specimen Thermocouples***

The Specimen Thermocouples positions differ slightly between AS 1530.4-2014 and AS 1530.4-1997. The difference would not have affected the outcome of the test if tested in accordance with AS 1530.4-2014.

### ***Integrity Criteria***

The integrity criteria differ slightly between AS 1530.4-2014 and AS 1530.4-1997. For AS 1530.4-2014, the penetration shall be deemed to have failed the integrity when;

- a) Flaming occurs or
- b) when a 6mm x 150mm gap gauge can pass through the specimen.
- c) Failed cotton pad

The integrity criteria for AS 1530.4-1997 deem a penetration to have failed integrity if a crack or fissure opens during the test that allows the passage of hot gases or flames.

Since the cable tray penetration in FSP 0768 did not form any cracks or fissures at the penetration seal, the differences in these criteria are not significant.

### ***Insulation Criteria***

The insulation criteria differ slightly between AS 1530.4-2014 and AS 1530.4-1997. For AS 1530.4-2014, the penetration shall be deemed to have failed the insulation when the thermocouple located on the specimen or the separating element exceeds the initial temperature by more than 180° K.

The insulation criteria specified in AS 1530.4-1997 are the same as that of AS 1530.4-2014.

### ***Application of Test Data***

On the basis of the discussion above, it is concluded that the results obtained from the referenced fire resistance tests conducted in accordance with AS 1530.4-1997 can be applied to an assessment of the integrity performance of the metal pipe penetrations tested in FSP 0768 if tested in accordance with AS 1530.4-2014 up to 198 minutes integrity only.



## A.7 Exova Warringtonfire Report EWFA 51894700.1

On 13 April 2018, Exova Warrington Fire, VIC conducted a fire test in accordance with AS 1530.4-2014 on a 175mm thick concrete slab penetrated by various pipes and cables protected by Trafalgar Fyrebox Maxi and Fyrebox Mini, Fyrebox Cast-in penetration protection systems. Only penetration 4 is discussed in this assessment.

The test assembly comprised a nominal 1200mm long × 1200mm wide × 180mm thick concrete floor system. An 800mm × 375mm opening was located on the north section of the floor system. A 1000mm × 575mm × 60mm thick Maxilite board was installed on top of the opening.

Only specimen 4 is discussed in the report. Its construction and performance are summarized below in A.28 Summary of test data.

## A.8 Warringtonfire Report FRT 180931.1

On 23 November 2018, Exova Warrington Fire, VIC conducted a fire test in accordance with AS 1530.4-2014 on a 175mm thick concrete slab penetrated by various services.

Specimens A, B and C are discussed in the report. Their construction and performance are summarized below in A.28 Summary of test data.

## A.9 CSIRO Report FSP 2052

On the 23 September 2019, CSIRO North Ryde conducted a fire test in accordance with AS 1530.4-2014 on an 1150mm x 1150mm x 150mm thick concrete slab penetrated by two electrical cable trays and three separate bundles of cables.

Specimens 3-5 are discussed in the report. Their construction and performance are summarized below in A.28 Summary of test data.

## A.10 Warringtonfire Report FRT 190292.5

On 16 January 2020, Warrington Fire, VIC conducted a fire test in accordance with AS 1530.4-2014 on a 175mm thick concrete slab penetrated by various services.

Specimens E1, E2 and G are discussed in the report. Their construction and performance are summarized below in A.28 Summary of test data.

## A.11 Warringtonfire Report FRT 180392.1

On 27 November 2018, Exova Warrington Fire, VIC conducted a fire test in accordance with AS 1530.4-2014 on a 116mm thick plasterboard wall penetrated by various services.

Specimens A, B, C, D, F, H and J are discussed in the report. Their construction and performance are summarized below in A.28 Summary of test data.

## A.12 BRANZ Report FP 6033

On 26 May 2017, BRANZ, NZ conducted a fire test in accordance with AS 1530.4-2014 on a 90mm thick plasterboard wall penetrated by various services. Specimens 8 and 9 are discussed in the report. Their construction and performance are summarized below in A.28 Summary of pipe test data.



### A.13 BRANZ Report FP 6372

On 3 July 2018, BRANZ, NZ conducted a fire test in accordance with AS 1530.4-2014 on a 75mm thick Hebel Powerpanel wall penetrated by various services. Specimen 2b is discussed in the report. Its construction and performance are summarized below in A.28 Summary of test data.

### A.14 BRANZ Report FP 11935-001

On 14 August 2019, BRANZ, NZ conducted a fire test in accordance with AS 1530.4-2014 on various services penetrating a nominally 2,200 mm high x 1,000 mm wide x 116 mm thick steel stud wall lined with two layers of 13 mm thick USG Boral Firestop plasterboard on each face. Specimens 1, 2 and 3 are discussed in the report. Their construction and performance are summarized below in A.28 Summary of test data.

### A.15 CSIRO Report FSP 1753

On 9 June 2016, CSIRO North Ryde conducted a fire test in accordance with AS 1530.4-2014 on a 75mm thick Hebel wall penetrated by various services. Specimen 4 is discussed in the report. Its construction and performance are summarized below in A.28 Summary of test data.

### A.16 CSIRO Report FSP 1729A

On 25 November 2015, CSIRO North Ryde conducted a fire test in accordance with AS 1530.4-2014 on a 96 mm thick steel stud wall penetrated by various services. Specimen 2 is discussed in the report. Its construction and performance are summarized below in the tables below in A.28 Summary of test data.

### A.17 CSIRO Report FSP 1795

On 14 March 2016, CSIRO North Ryde conducted a fire test in accordance with AS 1530.4-2014 on a 75mm thick Hebel wall penetrated by various services. Specimen 2 is discussed in the report. Its construction and performance are summarized below in A.28 Summary of test data.

### A.18 Warringtonfire Report FRT 190298 R1.1

On 23 January 2020, Warrington Fire, VIC conducted a fire test in accordance with AS 1530.4-2014 on a 78mm thick Speedpanel wall penetrated by various services. Specimen A is discussed in the report. Its construction and performance are summarized below in the tables in A.28 Summary of test data.

### A.19 Warringtonfire Report FRT 180323 R4.0

On 29 November 2018, Warrington Fire, VIC conducted a fire test in accordance with AS 1530.4-2014 on a 78mm thick Speedpanel wall penetrated by various services. Specimens G and H are discussed in the report. Their construction and performance are summarized below in the tables in A.28 Summary of test data.

## A.20 CSIRO Report FSP 2146

On the 17<sup>th</sup> of September 2020., CSIRO North Ryde conducted a fire test in accordance with AS 1530.4-2014 on four service penetrations installed through a 150mm thick concrete slab. Specimens 1,2 and 3 are discussed in the report. Their construction and performance are summarized below in A.28 Summary of test data.

## A.21 Warringtonfire Report FRT 200160.2

On 19 May 2020, Warrington Fire, VIC conducted a fire test in accordance with AS 1530.4-2014 on a 60mm thick Pronto Panel wall penetrated by various services. Specimen E is discussed in the report. Its construction and performance are summarized below in the tables in A.28 Summary of test data.

## A.22 Warringtonfire Report FRT 200397 R1.2

On 22 December 2020, Warrington Fire, VIC conducted a fire test that was stated to be in accordance with AS 1530.4-2014 on a 78mm Speedpanel wall penetrated by various services and protected with Trafalgar products.

Upon close inspection of FRT200397 R1.2 and its test photos, it was found that various services in this report were not reported in compliance with AS 1530.4-2014 and that specimens are placed in close proximity to each other.

However, the subject of this assessment, Specimens 10 and 11, was reported correctly and can thus be used in this assessment. Its construction and performance are summarized below in the tables in A.28 Summary of test data. The proximity issue will be addressed in Appendix B.

## A.23 CSIRO Report FSP 2249

On the 29 November 2021, CSIRO North Ryde conducted a fire test in accordance with AS 1530.4-2014 on four service penetrations installed through a 75mm thick AAC panel. Specimen 4 is discussed in the report. Its construction and performance are summarized below in A.28 Summary of test data.

## A.24 Warringtonfire Report FRT 210467

On 9 February 2022, Warrington Fire, VIC conducted a fire test accordance with AS 1530.4-2014 on various services penetrating a 150mm thick concrete slab. Specimens F and G are discussed in the report. Their construction and performance are summarized below in the tables in A.28 Summary of test data.

## A.25 CSIRO Report FSP 2317

On the 13 October 2022, CSIRO North Ryde conducted a fire test in accordance with AS 1530.4-2014 on various service penetrations installed through a 150mm thick slab. Specimens 5 and 6 are discussed in the report. Their construction and performance are summarized below in A.28 Summary of test data.

## A.26 Warringtonfire Report FRT 220112

On 11 August 2022, Warrington Fire conducted a fire test in accordance with AS 1530.4-2014 on various specimens penetrating a Corex board wall system. The wall system comprises 2 layers of 20mm thick Corex board on a 64mm thick stud.

Upon close inspection of FRT 220112 and its test photos, it was found that the thermocouple locations on various services are not in compliance with AS 1530.4-2014. The effect of the thermocouple locations will be discussed in Appendix B.

Only specimens A, E and G are discussed in the report. Their construction and performance are summarized below in the tables in A.28 Summary of test data.

## A.27 CSIRO Report FSP 2230

On 28 September 2021, CSIRO North Ryde conducted a fire test in accordance with AS 1530.4-2014 on various services penetrating a 41mm thick plasterboard wall system. Only specimen 4 is discussed in the report. Its construction and performance are summarized below in A.28 Summary of test data.

## A.28 Summary of test data

**Table A1: Summary of test data for metal pipes in floors**

Test specimen	Support construction	Fyreflex Depth (mm)	Annular gap (mm)	Fillet on Unexp. side (H x W) (mm)	Twrap Unexp. side (mm)	Pipe	Integrity (min.)	Insulation (min.)
NI 2689 (H)	75mm E core panel	30 + 2x25mm layers of Insugard	20	50 x 50	N/A	200mm x 2.3mm Copper	123NF	118 (on Support Construction)
NI 3089 (A)	125mm FyreSet Mortar /Bondek	115	10 - 17mm	20 x 50	N/A	200mm x 2.3mm Copper	228	24
FSP 0768 (A)	80mm FyreSet Mortar + 5mm Hardiflex	50	20	20 x 50	N/A	50mm Copper	198NF	16
FSP 0768 (B)	80mm FyreSet Mortar + 5mm Hardiflex	30	5	20 x 50	N/A	150mm Copper	198NF	13
NI 2689 (A)	75mm E core panel	30	20	20 x 50	N/A	100mm x 1.2mm Bass	123NF	-
NI 3089 (E)	125mm FyreSet Mortar /Bondek	30	15-30	20 x 50	N/A	114mm x 4.5mm Steel	244NF	28

Test specimen	Support construction	Fyreflex Depth (mm)	Annular gap (mm)	Fillet on Unexp. side (H x W) (mm)	Twrap Unexp. side (mm)	Pipe	Integrity (min.)	Insulation (min.)
NI 1089 (C)	115mm concrete slab	30	23	20 x 50	N/A	114mm x 4.5mm Steel	240 NF	30
FRT 180391.1 (A)	175mm concrete slab	50	10	15 x 15	300	50 x 1.22mm copper	241NF	143
FRT 180391.1 (B)	175mm concrete slab	50	10	15 x 15	700	150 x 2.03mm copper	171	70
FRT 190292.5 (E2)	60mm White Maxilite	60	19	30 x 30	800	100mm x 1.63mm copper	214	150 (Twrap) 212 (pipe)
FRT 190292.5 (G)	175mm concrete slab	50	10	30 x 30	600	152.4 x 5.3mm steel	241	170
FSP 2146 (1)	150mm concrete slab	60	12	30 x 30	600 Fyre-wrap	100mm x 1.6mm copper	142	133
FSP 2146 (2)	150mm concrete slab	60	9 - 28	40 x 40	450	114mm x 4.5mm Steel	241NF	126
FSP 2146 (4)	150mm concrete slab	60	12	30 x 30	600 Twrap	100mm x 1.6mm copper	92	82
FRT 210467 (F)	150mm concrete slab	60	8.5	30 x 30	Mono-wrap	38mm x 1.22mm copper	240NF	155(pipe)
FRT 210467 (G)	150mm concrete slab	60	8.5	30 x 30	Twrap	38mm x 1.22mm copper	240NF	169(pipe)
FSP 2317	150mm concrete slab	60	8-18	20 x 30	300mm Twrap	54mm x 1.5mm stainless steel	241NF	241NF
FSP 2317	150mm concrete slab	60	5-25	30 x 30	600mm Twrap	170mm x 1.5mm stainless steel	241NF	95 (pipe) 101 (wrap)

**Table A2: Summary of test data for metal pipes in walls**

Test specimen	Support construction	Fyreflex Depth (mm)	Annular gap (mm)	Fillet on unexp side (H x W) (mm)	Twrap each side (mm)	Pipe	Integrity (min.)	Insulation (min.)
FRT 180392.1 (A)	116mm Plasterboard lined stud wall	26+26	7	15 x 15	350 (overlap of wrap)	50 x 1.22mm copper	130NF	130NF
FRT 180392.1 (B)	116mm Plasterboard lined stud wall	26+26	7	15 x 15	300 (no overlap of wrap)	50 x 1.22mm copper	130NF	116 (wrap)
FRT 180392.1 (D)	116mm Plasterboard lined stud wall	26+26	9	10 x 10	500	100mm x 1.63mm copper	130NF	95 (pipe)
FRT 180392.1 (F)	116mm Plasterboard lined stud wall	26+26	4	15 x 15	400	114.64m m x 4.58mm Steel	130NF	130NF
FRT 180392.1 (H)	116mm Plasterboard lined stud wall	26+26	10	15 x 15	800	150x 2.03mm copper	130NF	51 (pipe) 110 (wrap) 118 (wall)
FP 6033 (9)	90mm Plasterboard lined stud wall	13+13	5	50 x 50	300	100mm x 1.7mm copper	92NF	50 (pipe) 67 (wall)
FP 6372 (2b)	75mm AAC	75	6	15 x 15	300	50mm x 1.22mm copper	125NF	117(pipe)
FP 11935-001(1)	60mm Blue Maxilite	60	10	50 x 50	420mm fireside 600mm non-fireside (75mm overlap)	100mm x 1.7mm copper	180NF	88 (Maxilite) 136 (wrap)
FP 11935-001(2)	60mm Blue Maxilite	60	10	50 x 50	1 x 420mm wrap on fireside 1100mm non-fireside + 300mm 2 <sup>nd</sup> Twrap	150mm x 1.8mm copper	180NF	104 (Maxilite) 137 (wrap)
FSP 1753 (4)	75mm AAC	20 each side	8.5	15 x 15	300	48mm x 3.5mm steel	121NF	121NF
FRT 190298 R1.1 (A)	78mm Speedpanel	78	3.5	30 x 30	300mm fireside 450mm non-fireside	100mm x 3.1mm steel	121NF	113 (Speed-panel)

Test specimen	Support construction	Fyreflex Depth (mm)	Annular gap (mm)	Fillet on unexp side (H x W) (mm)	Twrap each side (mm)	Pipe	Integrity (min.)	Insulation (min.)
FRT 200160.2 (E)	60mm Pronto Panel	60	16	40 x 40	NA	48mm x 3.2mm steel	121NF	71
FRT200397 R1.2 (10)	2 x 60m Fyrebatt	120	12.45	50 x 50	300mm fireside 450mm non-fireside	150mm x 4.9mm steel	241NF	119(pipe) 213(batt) 231(wrap)
FRT200397 R1.2 (11)	2 x 60m Fyrebatt	120	13.8	50 x 50	300mm wrap on the fireside, 1100mm + 300mm on the non-fireside	150mm x 2.03mm copper	241NF	241NF
FRT 220112 (G)	2 x 20mm Corex board on 64mm stud	40	5	15 x 15	600mm each side	101.6mm x 1.6mm copper	121NF	92(on wall, pipe)
FSP 2230 (4)	25mm thick shaftliner board laminated to 16mm firestop plasterboard	41	12.6	30 x 30	300mm each side	50.8mm x 1.22mm copper	98NF	98NF

**Table A3: Summary of test data for cables penetrating floors**

Test specimen	Support construction	Fyreflex Depth (mm)	Annular gap (mm)	Fillet (H x W) (mm) and Twrap	Protected item	Integrity (min.)	Insulation (min.)
NI1089 (B)	115mm thick concrete slab	100	10-32	50 x 50 Unexposed side	46mm dia. power cable 16mm Dia. 3-core plus power cable 6 NO. 50 pair telecommunications cable in 110mm dia. hole	240NF	110
NI 2689 (D)	75mm E core panel	75	6	50 x 50 Unexposed side	1 x 38mm dia. 3C + E power cable with PVC insulation and sheathing	123NF	NA
NI 2689 (F)	75mm E core panel	75	6	50 x 50 Unexposed side	6 x 4 bundle of 100 strand Telecom cables, 15mm Dia. with PVC sheathing and insulation	123NF	NA
NI 2689 (G)	75mm E core panel	30	20	20 x 50 Unexposed side	2 copper busbars 50 x 10mm spaced 10 mm apart	123NF	NA

Test specimen	Support construction	Fyreflex Depth (mm)	Annular gap (mm)	Fillet (H x W) (mm) and Twrap	Protected item	Integrity (min.)	Insulation (min.)
NI 2689 (J)	75mm E core panel	75	6	50 x 50 Unexposed side	1 x 38mm OD 3C+E PVC sheathed and insulated, with 4 x 20mm OD single core with double PVC sheathing	123NF	NA
NI 2689 (L)	75mm E core panel	75	6	50 x 50 Unexposed side	3 x 16mm OD 3C+E power cables. 6 x 100 strand telecom. cables 15mm Dia. 1x 46mm OD single-core power, 1x 29mm OD 3C+E power. All were PVC sheathed and insulated	123NF	NA
EWFA 51894700.1 (4)	60mm Maxilite	60	10 -15	30 x 30 Exposed side	2 x TPS power cable	241NF	70
FSP 2052 (3)	150mm thick concrete slab	65	65mm hole	30 x 30 Unexposed side	Up to 20 x 6mm OD CAT6	121NF	121NF
FSP 2052 (4)	150mm thick concrete slab	70	65mm hole	40 x 40 Unexposed side	Up to 20 x 6mm OD Firesense 2.5mm <sup>2</sup> cables	121NF	121NF
FSP 2052 (5)	150mm thick concrete slab	70	80mm hole	40 x 40 Unexposed side	10 x 6mm OD CAT6 10 x 6mm OD Firesense 2.5mm <sup>2</sup> cables, 10 x 10 x 4mm TPS cables	121NF	121NF
FRT 190292.5 (E1)	60mm thick horizontal White Maxilite	60	20-30	50 x 50 and 450mm Twrap on the unexposed side	Appendix A D1 cables on 315mm wide x 50mm cable tray 1 x 49mm OD 3C+E cable 185mm <sup>2</sup> 1 x 41mm OD single cable 630mm <sup>2</sup> 3 x 15mm OD 3C+E cable 6mm <sup>2</sup> 8 x 20mm OD 3C+E cable 16mm <sup>2</sup>	241NF	154

Test specimen	Support construction	Fyreflex Depth (mm)	Annular gap (mm)	Fillet (H x W) (mm) and Twrap	Protected item	Integrity (min.)	Insulation (min.)
FRT 180931.1 (C)	60mm thick horizontal Blue Maxilite	60	20-30	50 x 50 300mm Twrap on the unexposed side	Appendix A D1 cables on 300 x 47mm cable tray: 1 x 50mm OD 3C+E cable 185mm <sup>2</sup> 1 x 43mm OD single cable 630mm <sup>2</sup> 3 x 15mm OD 3C+E cable 6mm <sup>2</sup> 8 x 20mm OD 3C+E cable 16mm <sup>2</sup>	165	62

**Table A4: Summary of test data for cables in walls**

Test specimen	Support construction	Fyreflex Depth (mm)	Annular gap (mm)	Fillet (H x W) (mm)	Twrap each side (mm)	Protected item	Integrity (min.)	Insulation (min.)
FP 11935-001 (3)	60mm blue Maxilite	60	20	50 x 50	300mm Twrap each side of the cable and the cable tray was packed with loose TWrap infill material	Appendix A D1 cables on 300mm x 47mm cable tray: 1 x 48mm OD 3C+E cable 185mm <sup>2</sup> 1 x 45mm OD single cable 630mm <sup>2</sup> 3 x 15mm OD 3C+E cable 6mm <sup>2</sup> 8 x 20mm OD 3C+E cable 16mm <sup>2</sup>	180NF	144 (cable tray)
FRT 180392.1 (J)	2x13mm plasterboard on 64mm stud (total 116mm)	26 +26	20	15 x 15	300mm Twrap each side of the cable	5 x TPS cables 2.5mm <sup>2</sup> (5.29X1 2.1) and 5 x CAT6 cables(5.75mm diameter)	130NF	130NF
FRT 180392.1 (C)	2x13mm plasterboard on 64mm stud (total 116mm)	26 +26	110mm hole	30 x30	300mm Twrap each side of the cable	8 x 3Core + Earth power cables	130NF	130NF
FP 6033 (8)	1x13mm plasterboard on 64mm stud (total 90mm)	13+13	5	50 x 50	None	3 x 19 mm OD, 3C+E 16mm <sup>2</sup> power cables	92NF	68(wall )



Test specimen	Support construction	Fyreflex Depth (mm)	Annular gap (mm)	Fillet (H x W) (mm)	Twrap each side (mm)	Protected item	Integrity (min.)	Insulation (min.)
FSP 1729A (2)	16mm plasterboard on each side of 64mm stud (total 96mm)	16+16	5	30 x 30	None	3 x TPS power and 2 x Cat 6	121NF	94 (wall)
FSP 1795 (2)	75mm AAC	15	5	30 x 30	None	2x CAT6 6.3mm dia, and 2x TPS cables 2.5mm <sup>2</sup>	96NF	96NF
FRT 180323 R4.0 (G)	78mm Speedpanel	78	30mm hole	30 x 30	None	2x CAT6 (5.75mm diameter), 2x 2 Core + earth Prysmian Cable 2.5mm <sup>2</sup> (6.21m m OD) 2 X Firesense TP cable(5.1mm OD)	121NF	121NF
FRT 180323 R4.0 (H)	78mm Speedpanel	78	40mm hole	30 x 30	None	3 x 18mm OD 3 core and Earth Power 16mm <sup>2</sup> cable	121NF	46(seal ant)
FSP 2249 (4)	75mm AAC	75mm	40mm hole	30 x 30	None	4 x 6mm OD RG-6 Quad shield co-axial cables	121NF	121NF
FRT 220112 (A)	2 x 20mm Corex board on 64mm stud	40	54mm hole	50 x 50	300mm each side	10 x 12mm x 5mm TPS cables 2.5mm <sup>2</sup> , 10 x 7mm OD TPS fire 1.5mm <sup>2</sup> and 10 x 6mm OD CAT6 cables	121NF	103(on wall)
FRT 220112 (E)	2 x 20mm Corex board on 64mm stud	40	83mm hole	50 x 50	300mm each side	8 x 19mm OD, 3C+E 16mm <sup>2</sup> power cables	121NF	103(on wall)

## A.29 Installation detail Summary

Figures 1 to 14 are relabelled Figures A1 to A14 reproduced below to group all the figures in one place in the report.

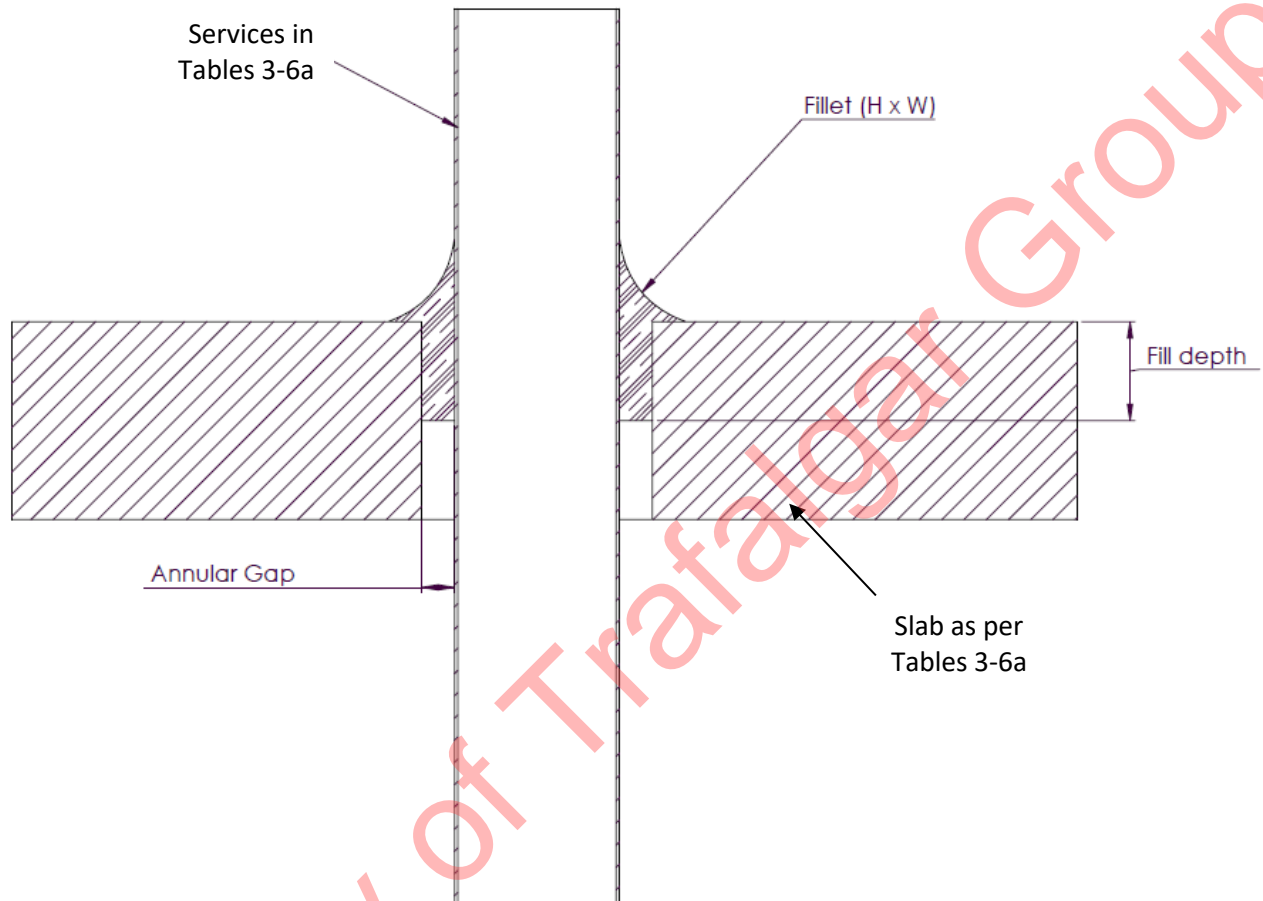
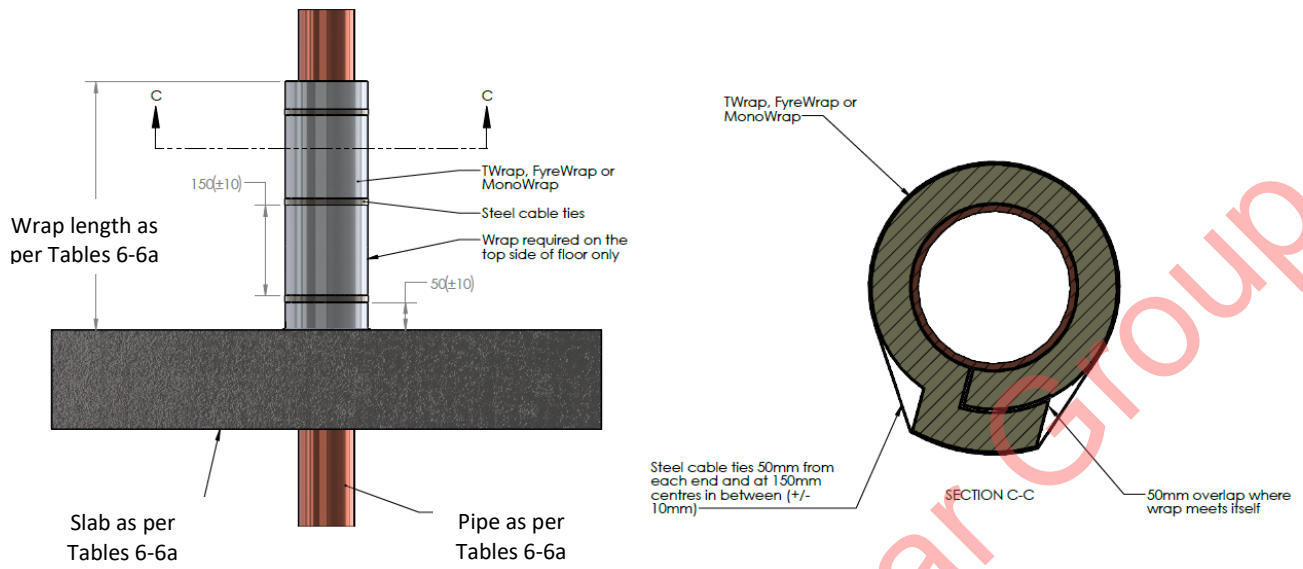
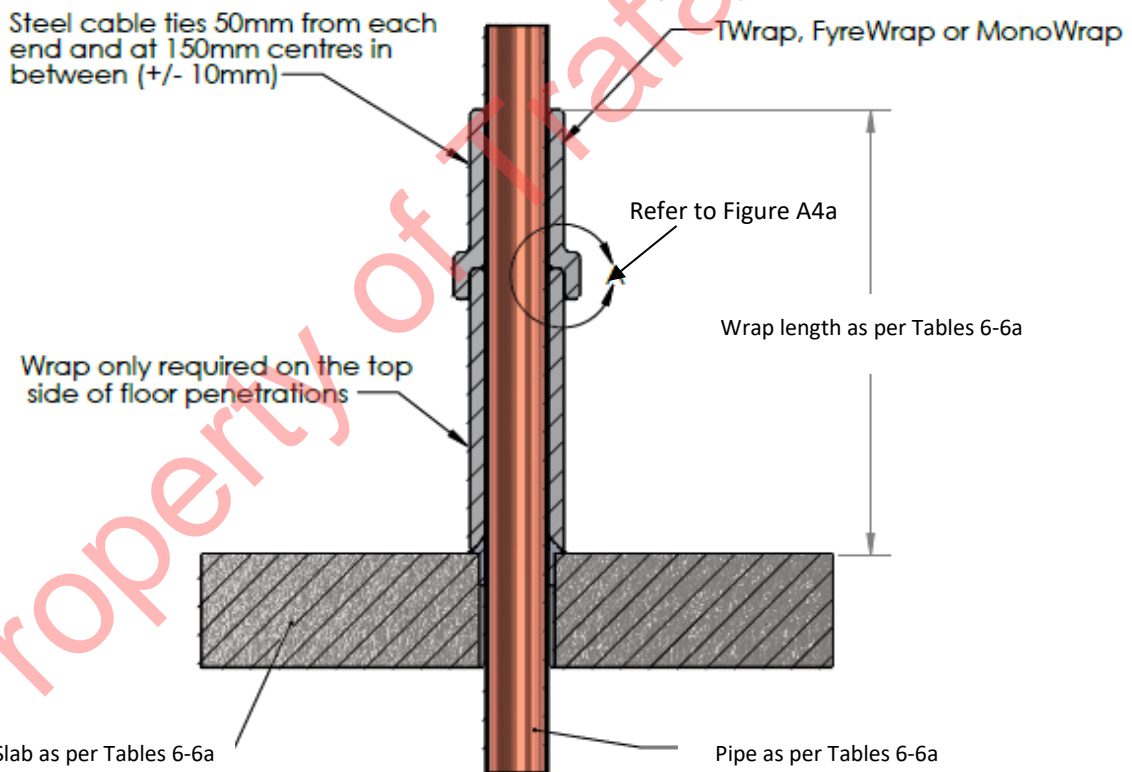


Figure A1: General services to slab sealant detail



**Figure A2: Wrap overlap and cable tie detail for metal pipes in slabs**



**Figure A3: Single layer wrap detail for metal pipes in slabs**

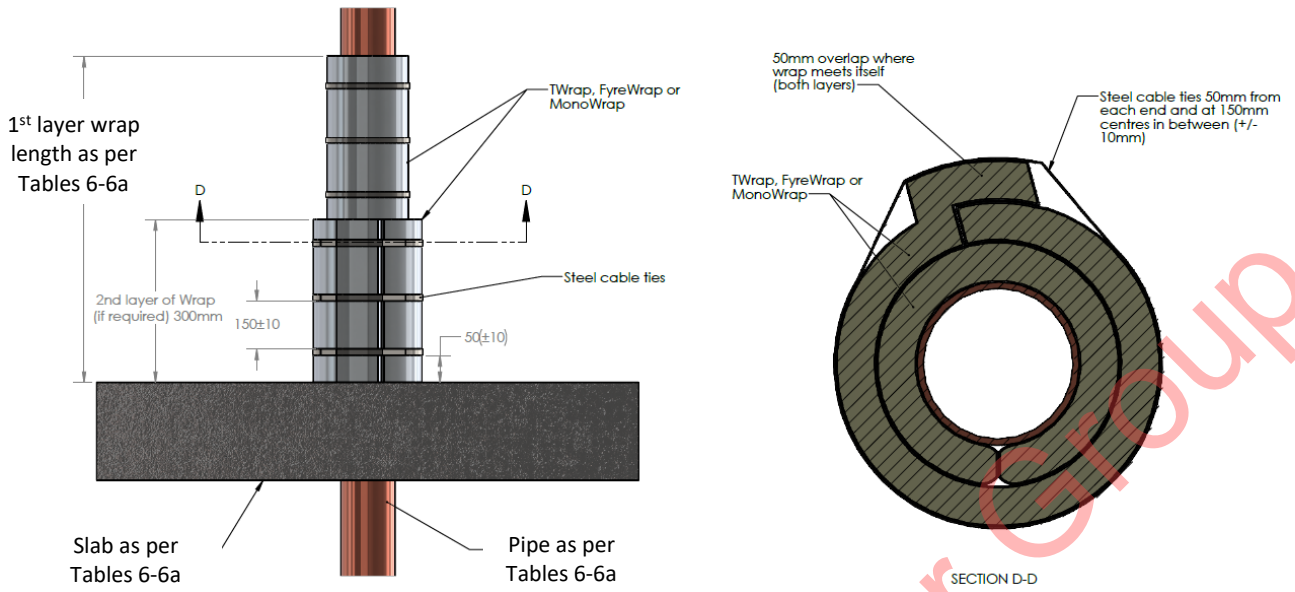


Figure A3a: Wrap overlap and cable tie detail for metal pipes in slabs

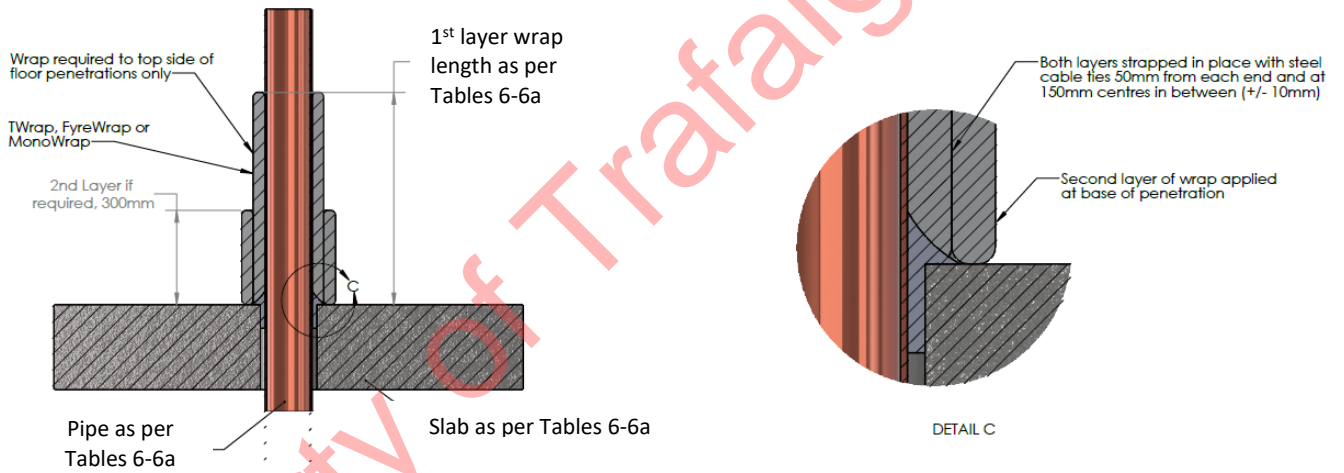


Figure A4: Double layer wrap detail for metal pipes in slabs

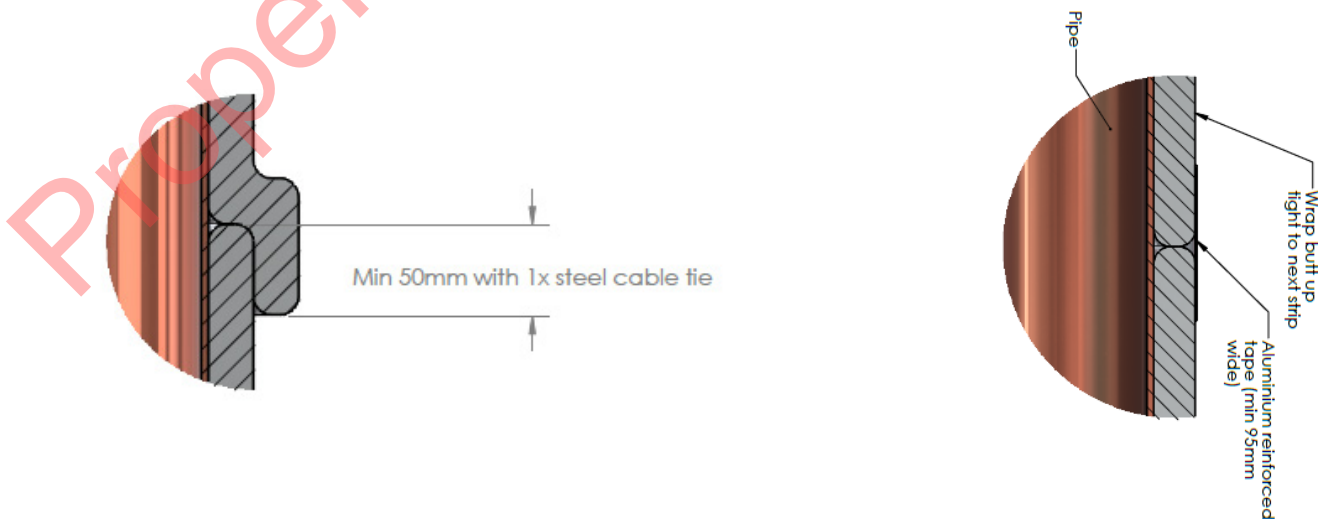


Figure A4a: Various wrap joint options

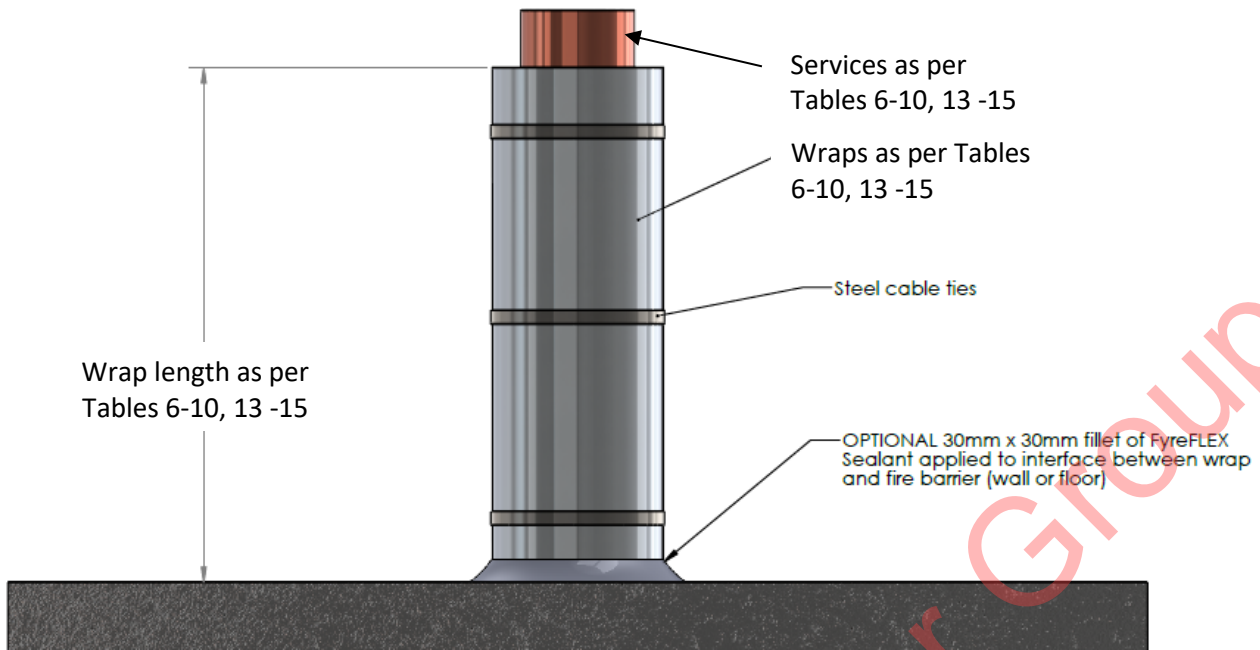


Figure A5: Optional additional fillet of sealant on top of wrap – general detail

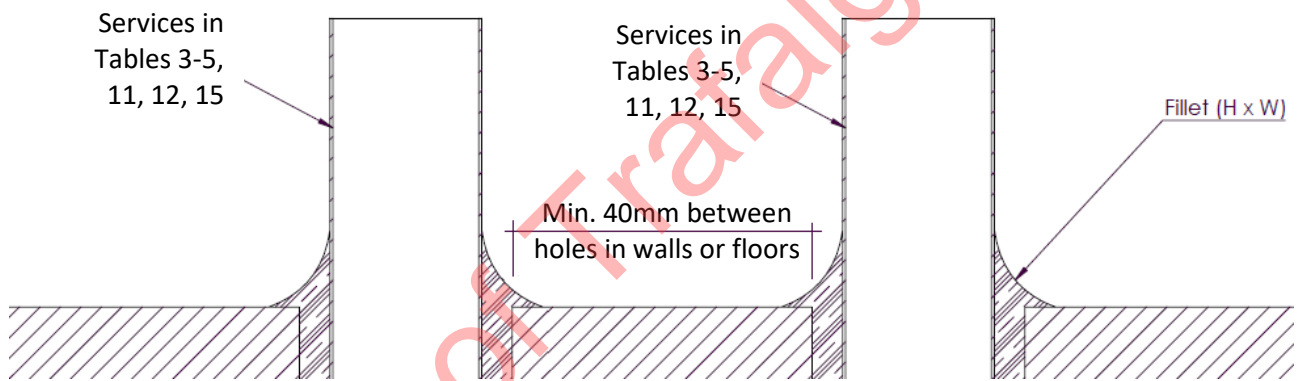
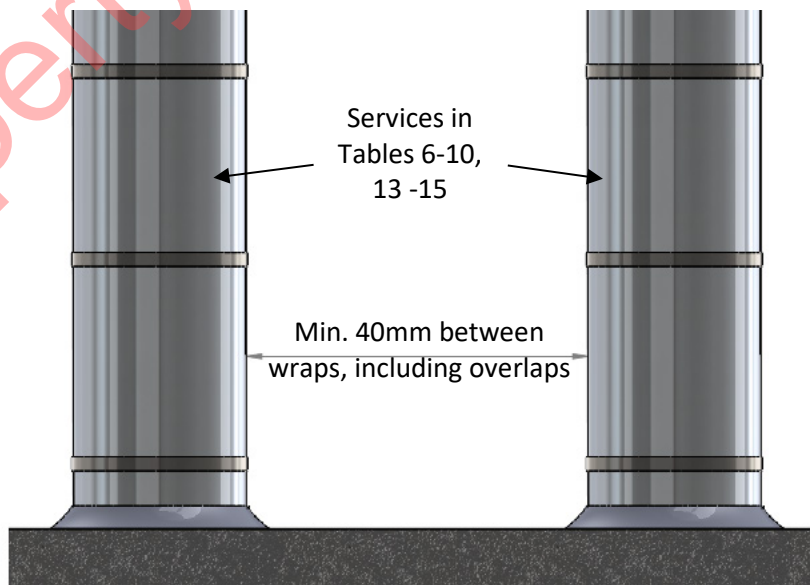
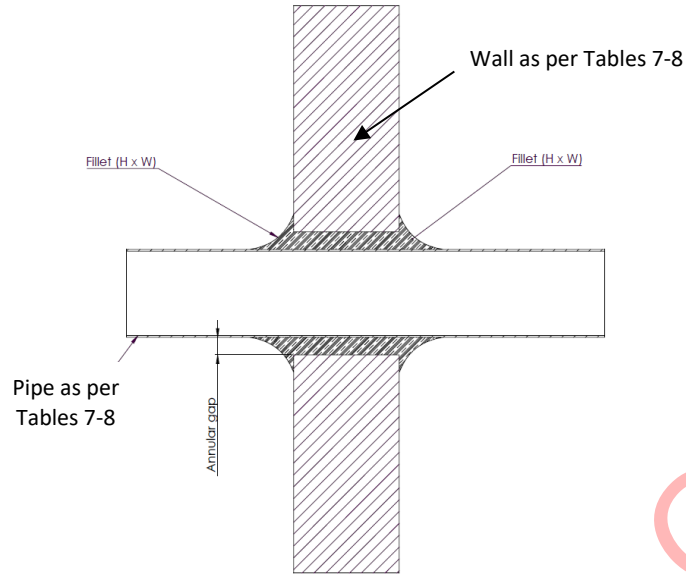


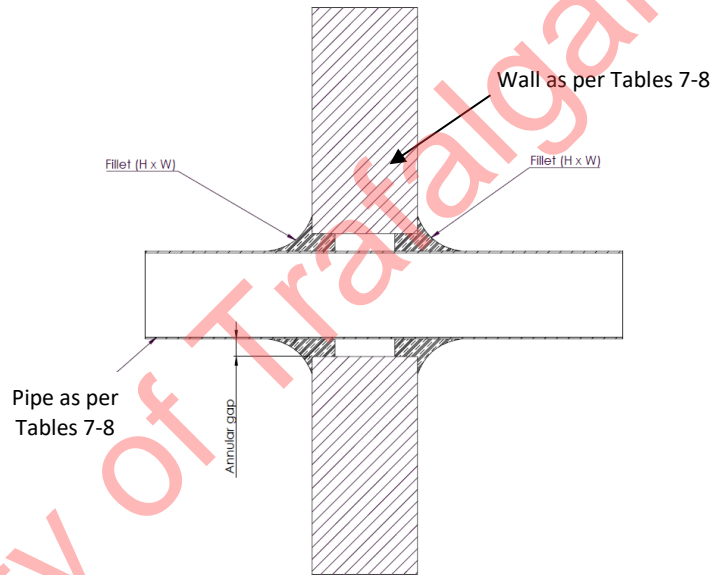
Figure A5a: Separation between metal pipes in walls or floors with no wrap - general detail



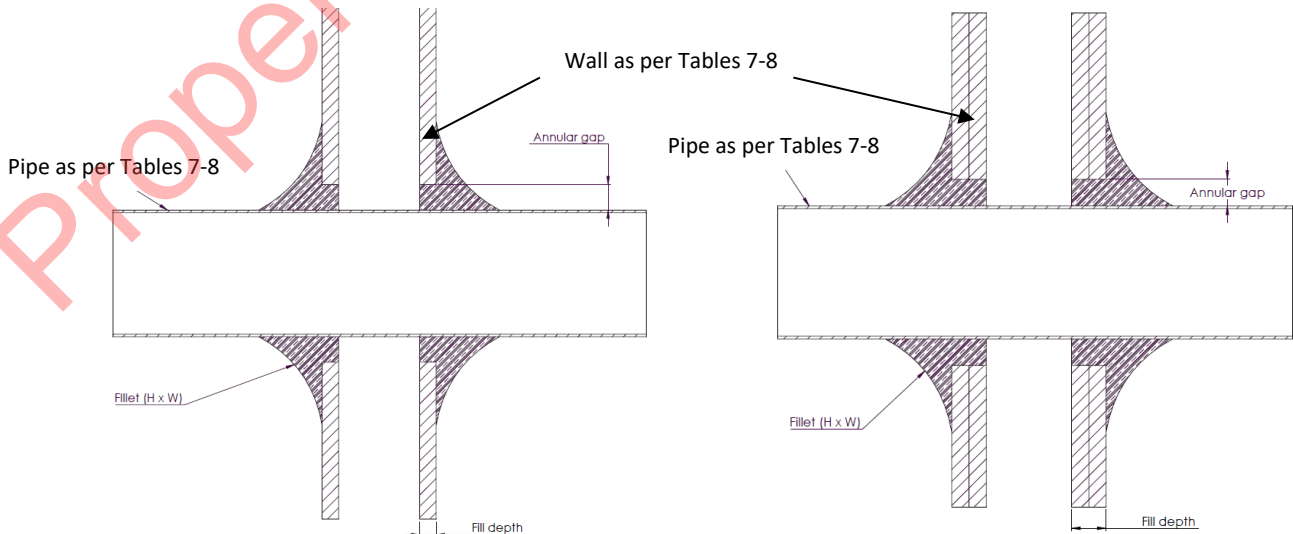
**Figure A5b: Separation between wrapped metal pipes in walls or floors - general detail**



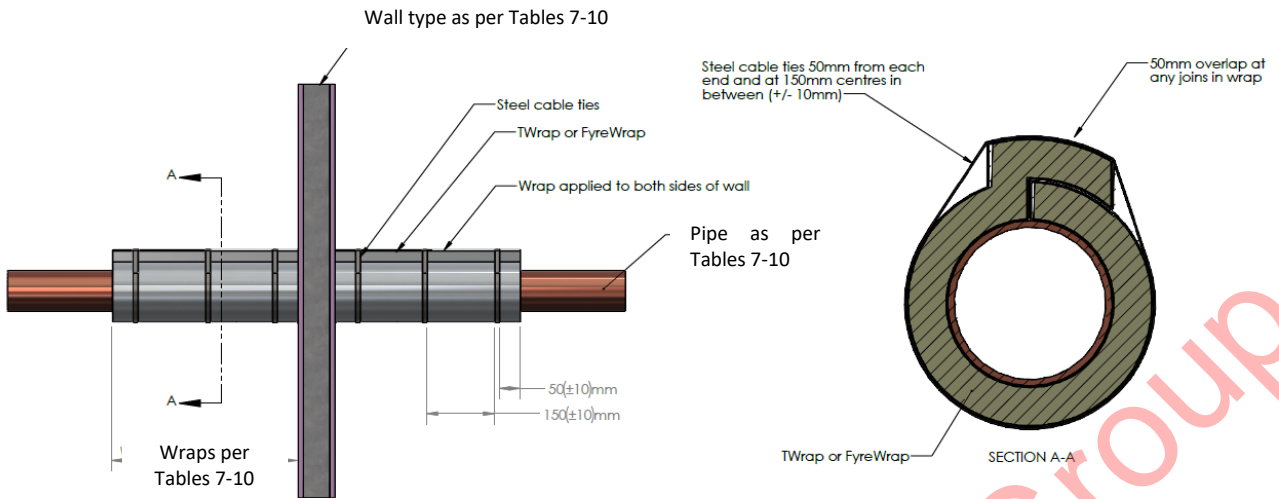
**Figure A6: Sealant detail for pipe in Hebel/Speedpanel walls – full depth sealant**



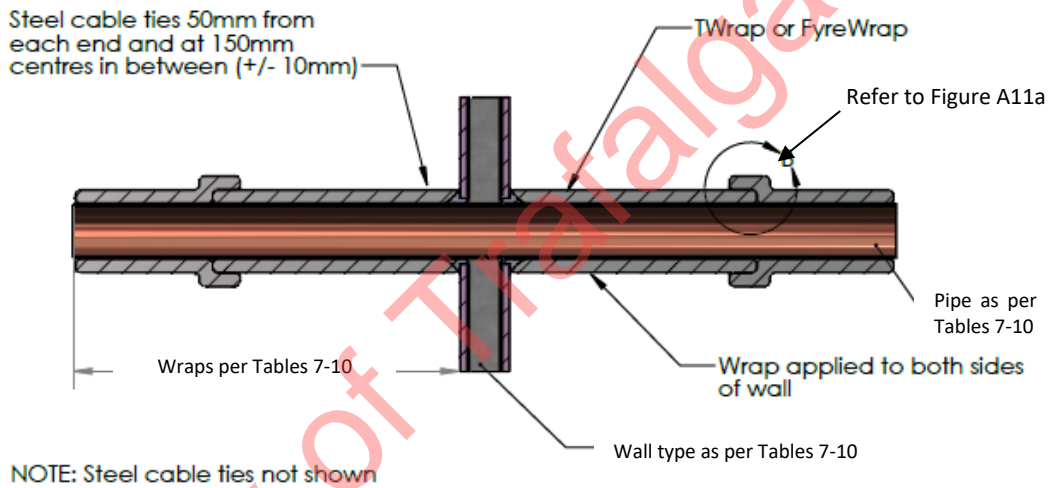
**Figure A7: Sealant detail for pipe in masonry/concrete walls – partially depth sealant**



**Figure A8: Sealant detail for pipe in plasterboard lined stud walls – sealant to the full depth of lining**

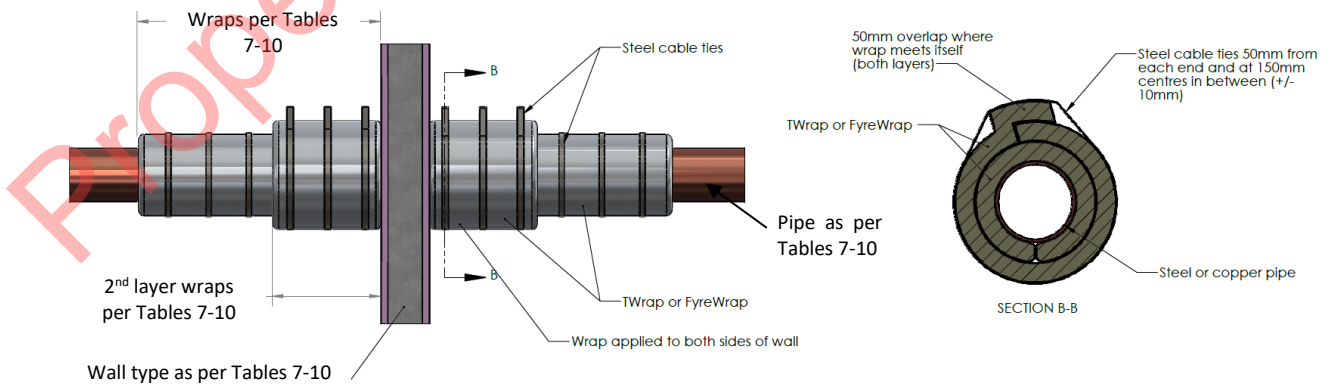


**Figure A9: Single layer wrap overlap and cable tie detail for metal pipes in walls**



NOTE: Steel cable ties not shown

**Figure A10: Single layer wrap detail for metal pipes in slabs**



**Figure A10a: Double layer wrap overlap and cable tie detail for metal pipes in walls**



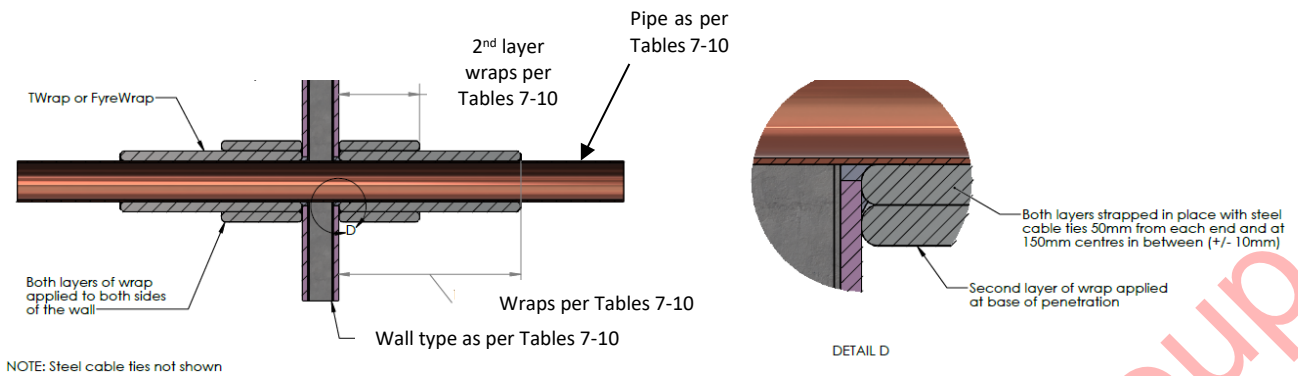


Figure A11: Double layer wrap detail for metal pipes in slabs

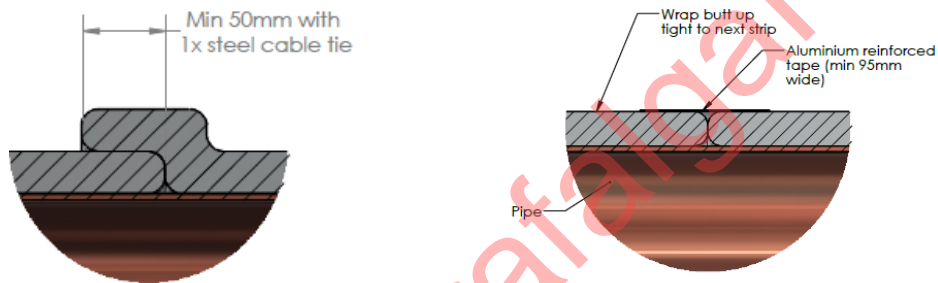


Figure A11a: Various wrap joint options

100 x 100 x 60mm Maxilite collar fixed with minimum 10gx100mm plasterboard screws. Screw fixings 25mm from each corner. Maxilite may be cut into halves and retrofit around pipe

Pipe as per Tables 9 -10

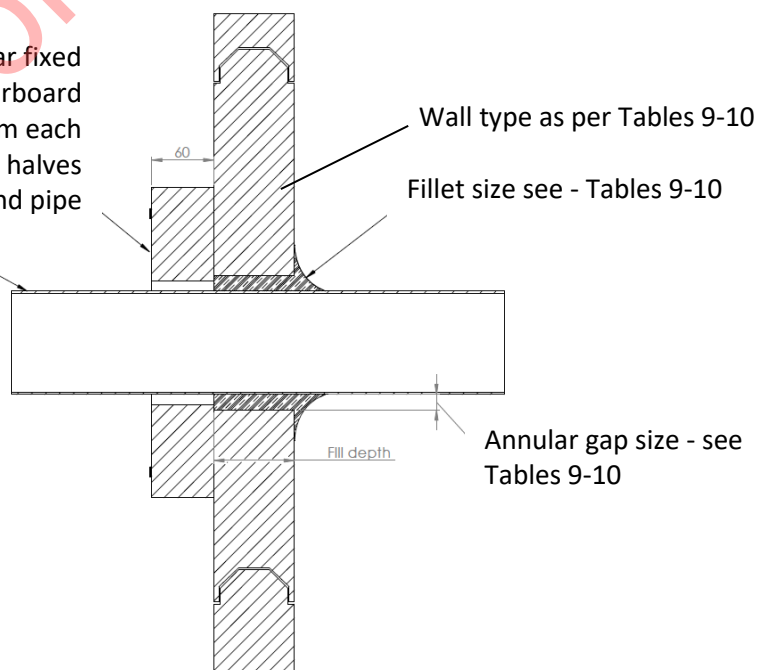
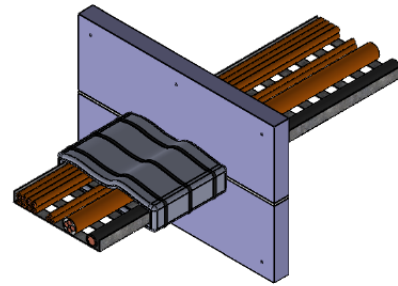
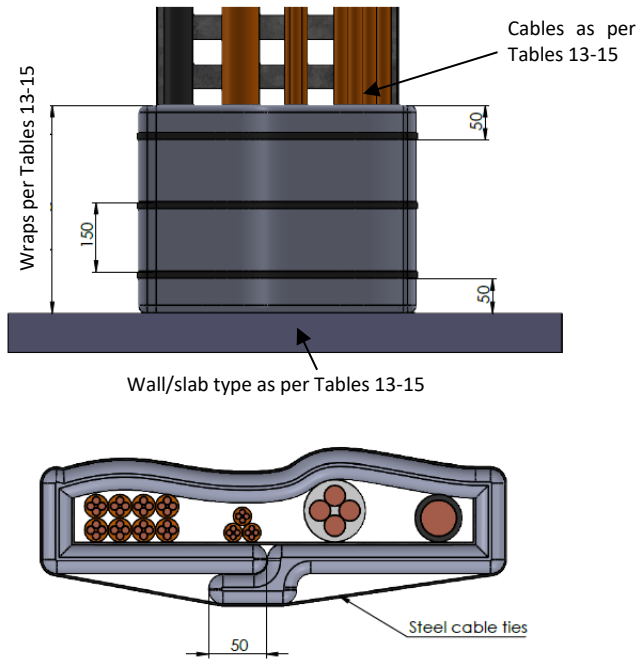


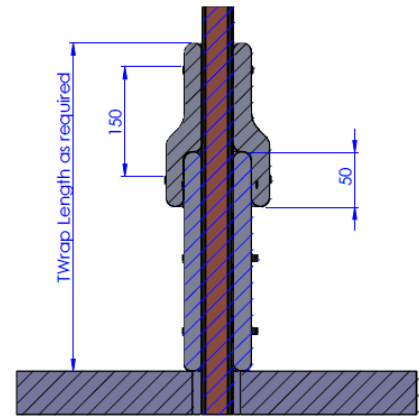
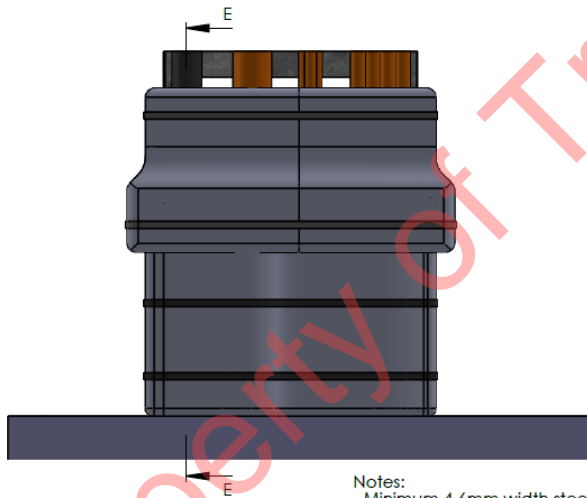
Figure A12: Typical detail of 60mm thick Maxilite collar around services





- Notes:
- Minimum 4.6mm width steel cable ties installed 50mm from each end, and at 150mm centres
  - Twrap to overlap 50mm along the length of the service
  - Voids between cables (on cable trays only) only to be packed with un-foiled Twrap material for at least 300mm

Figure A13: Generic detail of a single length of Twrap detail around cable services



- Notes:
- Minimum 4.6mm width steel cable ties installed 50mm from each end, and at 150mm centres
  - Twrap to overlap 50mm between adjacent sections
  - Voids between cables (on cable trays only) to be packed with un-foiled Twrap material for at least 300mm

Figure A14: Generic detail of multi-length of Twrap detail around services

## Appendix B Analysis of Variations

### B.1 Metal pipes penetrating floors - without wrap

The proposed construction shall be for penetrations in concrete floors as tested in NI 1089, NI 2689, NI 3089 and FSP 0768 when subject to the following variations;

- Variation of slab thickness to 120mm where possible
- Change the annular gap between the pipe and the support construction shall be up to 20mm.
- Variations in sealant depth and fillet size as shown in Table B1.
- Variations in pipe size and materials as shown in Table B1.
- The separation of the specimens shall be at least 40mm refer to Figure 5a

**Table B1: Metal pipes in concrete slabs**

Pipe material	Minimum Nom. Diameter (mm)	Annular gap (mm)	Minimum Fyreflex depth (mm)	Minimum fillet size on the unexposed side (h x w) (mm)	Minimum concrete slab thickness (mm)
Brass	100	10 -20	30	20x50	120
Copper	150	10 -20	30	20x50	120
		10 -20	50	20x50	150
	200	10 -20	30	50x50	120
		10 -20	115	50x50	150
Steel	114	10 -20	50	20x50	175
	150	10 -20	30	20x50	120
		10 -20	50	20x50	150
		10 -20	115	50x50	175
	200	10 -20	30	50x50	120
		10 -20	115	50x50	150

#### **Brass Pipes up to 100mm in diameter penetrating a minimum 120mm slab**

The proposed construction comprises 100mm maximum diameter brass pipes penetrating a minimum 120mm thick concrete slab, with a minimum 30mm deep Fyreflex sealant in a 10mm - 20mm annular gap and with a minimum of 20mm high x 50mm wide fillet of Fyreflex sealant on the unexposed side of the penetration.

With reference to NI 2689 specimen A, the 100mm OD brass pipe with a wall thickness of 1.2mm penetrated a 75mm E Core panel and was protected with a 30mm depth of Fyreflex sealant in a 20mm annular gap and a 20x50mm Fyreflex sealant fillet on the unexposed side. The specimen was able to maintain integrity for 123 minutes duration of the test.

A large thick metal pipe will conduct more heat than a smaller and thinner pipe. Therefore, it is considered reasonable and conservative to apply the result for NI 2689 specimen A to all brass pipes up to 100mm in diameter.

The proposed increase of support construction thickness from 75mm as tested in NI 2689 to a minimum of 120mm does not affect the sealant depth, and thus will not affect the integrity performance of the seal around the pipe penetration.

The increase of density of the support construction from the vermiculite based refractory panel as tested in NI 2689 to the much denser proposed concrete slab will also cool the over system down due

to the higher heat capacity of the concrete slab to absorb heat, allowing the penetration seal to be cooler in general.

Based on the above, it is expected that the proposed construction will be able to maintain integrity for up to 120 minutes when tested in accordance with AS 1530.4 – 2014 and assessed in accordance with AS 4072.1 -2005 Amdt. 1.

### ***Copper and Steel Pipes up to 200mm in diameter penetrating a minimum 120mm slab***

The proposed construction comprises copper and steel pipes up to 200mm in diameter penetrating a minimum 120mm thick concrete slab with a minimum 30mm deep Fyreflex sealant and a 10mm - 20mm annular gap and with a minimum 50mm high x 50mm wide fillet of Fyreflex sealant on the unexposed side of the penetration.

With reference to NI 2689 specimen H, where a 200mm diameter copper pipe with a wall thickness of 2.3mm penetrated a 75mm E core panel. It was protected with a 30mm depth of Fyreflex sealant in a 20mm annular gap. On the unexposed side, it has a 50x50mm Fyreflex sealant fillet as well as 2x25mm layers of Insuguards around the pipe. The specimen was able to maintain integrity for the 123 minutes duration of the test.

The proposed increase of support construction thickness from 75mm as tested in NI 2689 to a minimum of 120mm does not affect the sealant depth, and thus will not affect the integrity performance of the seal around the pipe penetration.

Also, the increase of density of the support construction from the vermiculite based refractory panel as tested in NI 2689 to the much denser proposed concrete slab will also cool the over system down due to the higher heat capacity of the concrete slab to absorb heat, allowing the penetration seal to be cooler in general.

The proposed construction does not have the two layers of Insuguard, which would then allow the cotton pad to be applied directly to the seal once any gap is observed.

In NI 2689, the only possible gap that was noted was a surface split in the Fyreflex seal at 30 minutes observed on Specimen A, B, G, H and K. Even though specimens A, B, G and K did not have Insuguard, the cotton pad was not applied to this specimen. This gives confidence that the surface split in the Fyreflex seal noted on specimen H also did not warrant a cotton pad. No gap was noted for specimen H for the rest of the test duration. Therefore, it is expected that without Insuguard, the proposed construction would be able to maintain integrity for 120 minutes.

Steel has a lower thermal conductivity than copper and when pipes are larger and thicker they will conduct more heat than a smaller and thinner pipe. Therefore, the result for NI 2689 specimen H may be applied to copper and ferrous metal pipes having outside diameters not greater than the tested diameter, and copper pipes with a wall thickness not more than the tested thickness in the referenced test.

For steel pipes, the slight increase in wall thickness can be tolerated as it will balance out the less conductive nature of the steel pipe. On balance, it is expected that the proposed steel pipe will perform similar or better than the tested pipe in the referenced test.

Confidence in the ability of the concrete slab to perform for the required FRL is offered by reference to AS 3600-2018 clause 5.5, where the required slab thicknesses by that standard are the same as those proposed for the given FRL.

Based on the above discussion, and in the absence of any foreseeable integrity or insulation weakness it is considered that the proposed construction will maintain integrity for up to 120 minutes when tested in accordance with AS 1530.4-2014 and assessed in accordance with AS 4072.1 -2005 Amdt. 1.

### ***Copper and Steel Pipes up to 200mm in diameter penetrating a minimum 150mm slab***

The proposed construction comprises copper and steel pipes up to 200mm in diameter penetrating a 150mm thick concrete slab with 115mm deep Fyreflex sealant in a 10mm - 20mm annular gap and with a minimum 50mm high x 50mm wide fillet of Fyreflex sealant on the unexposed side of the penetration.

With reference to NI 3089 specimen A, the 200mm diameter copper pipe with a wall thickness of 2.3mm penetrated a 230mm hole between 125mm thick Fyreset mortar and Bondek. It was protected with a 115mm depth of Fyreflex sealant in a 10-17mm annular gap and a 20x50mm Fyreflex sealant fillet on the unexposed side. The specimen failed integrity at 228 minutes.

The annular gap is to be increased to a maximum of 20mm which may decrease the integrity performance of the seal around the copper pipe. However, the proposed fillet size has increased from the tested 20mm x 50mm to 50mm x 50mm which will have more moisture in the acrylic sealant to cool the pipe down and improve the integrity performance of the seal.

The proposed increase of support construction thickness from the tested 125mm in NI 3089 to 150mm does not affect the sealant depth, and thus will not affect the integrity performance of the seal around the pipe penetration.

The proposed concrete slab has less heat capacity than the tested Fyreset mortar, which will result in a hotter support construction which may cause an earlier failure of the sealant seal. However, the proposed increase in slab thickness to 150mm will act to increase the heat absorption by the support construction and thus allow the penetration seal to be cooler overall and allow the penetration seal to maintain integrity for longer.

Steel has a lower thermal conductivity than copper and when pipes are larger and thicker they will conduct more heat than a smaller and thinner pipe. Therefore, the result for NI 3089 specimen A may be applied to copper and ferrous metal pipes having outside diameters not greater than the tested diameter, and copper pipes with a wall thickness not more than the tested thickness in the referenced test.

For steel pipes, the slight increase in wall thickness can be tolerated as it will balance out the less conductive nature of the steel pipe. On balance, it is expected that the proposed steel pipe will perform similar or better than the tested pipe in the referenced test.

Confidence in the ability of the concrete slab to perform for the required FRL is offered by reference to AS 3600-2018 clause 5.5, where the required slab thicknesses by that standard are the same as those proposed for the given FRL.

Based on the above discussion, and in the absence of any foreseeable integrity weakness it is considered that the proposed construction will maintain integrity for up to 180 minutes when tested in accordance with AS 1530.4-2014 and assessed in accordance with AS 4072.1 -2005 Amdt. 1.

### ***Copper and Steel Pipes up to 150mm in diameter penetrating a minimum 175mm slab***

The proposed construction comprises ferrous metal pipes up to 150mm in diameter penetrating a 175mm thick concrete slab with 115mm deep Fyreflex sealant in a 10mm - 20mm annular gap and with a minimum 50mm high x 50mm wide fillet of Fyreflex sealant on the unexposed side of the penetration.

With reference to NI 3089 specimen A, the 200mm diameter copper pipe penetrated a 230mm hole between 125mm thick Fyreset mortar and Bondek. It was protected with a 115mm depth of Fyreflex sealant in a 10-17mm annular gap and a 20x50mm Fyreflex sealant fillet on the unexposed side. The specimen failed integrity at 228 minutes due to sealant ignition. At 240 minutes, the copper pipe 25mm from the Fyreflex seal reached 829°C. The fillet of Fyreflex sealant measured 481°C at 240 minutes.

With NI 3089 specimen E, the 114mm diameter steel pipe penetrated a 160mm hole between 125mm thick Fyreset mortar and Bondek. It was protected with a 30mm depth of Fyreflex sealant in a 16-

30mm annular gap and a 20x50mm Fyreflex sealant fillet on the unexposed side. The specimen did not fail integrity for 244 minutes duration of the test. At 240 minutes, the steel pipe 25mm from the Fyreflex seal reached 509°C. The fillet of Fyreflex sealant measured 217°C at 240 minutes.

Steel has a lower thermal conductivity than copper and when pipes are larger and thicker they will conduct more heat than a smaller and thinner pipe. Therefore, the result for NI 3089 specimen A may be applied to copper and ferrous metal pipes having outside diameters not greater than the tested diameter, and copper pipes with a wall thickness not more than the tested thickness in the referenced test.

For steel pipes, the slight increase in wall thickness can be tolerated as it will balance out the less conductive nature of the steel pipe. On balance, it is expected that the proposed steel pipe will perform similar or better than the tested pipe in the referenced test.

This confidence is provided by a comparison of pipe temperatures between the 200mm copper pipe in specimen A and the 114mm steel pipe in specimen E showing that the copper pipe is much more conductive than the steel pipe. Therefore, it is expected that if a steel pipe of up to 150mm diameter were tested in the configuration that the copper pipe was tested in, it would have been much cooler than copper pipe at 240 minutes.

At 228 minutes, it was observed that the cap for the copper pipe melted off and thus allow hot gas to pass through the pipe igniting the sealant. For steel pipe, the cap will not be melted off due to its higher melting point. This gives further confidence that the sealant will not ignite for up to 240 minutes.

However, it is noted that the pipe specimens in NI 3089 only extended 100mm into the furnace and 2000mm away from the furnace as opposed to 500mm into and away from the furnace as required by AS 1530.4 – 2014. The pipes would, therefore, be hotter at an earlier stage.

The proposed 150mm steel pipe size is also less than the 200mm copper pipe tested in NI 3089, which will again allow the pipe to be cooler and potentially improve the integrity performance of the proposed pipe compared to the tested copper pipe.

The proposed annular gap is slightly larger than that tested in NI 3089, which may potentially decrease the integrity performance of the seal around the copper pipe. However, the proposed fillet size has increased from the tested 20mm x 50mm to 50mm x 50mm which will act to compensate for the slight increase in annular gap size. The larger acrylic fillet will also have more moisture content to cool the pipe temperature.

The proposed concrete slab has lower insulation performance per mm thickness than the tested Fyreset mortar. However, the proposed increase in slab thickness to a minimum of 175mm will act to maintain the insulation performance of the support construction and increase the overall depth, thus allowing the penetration seal to be cooler overall and allow the penetration seal to maintain integrity for longer.

Confidence in the ability of the concrete slab to perform for the required FRL is offered by reference to AS 3600-2018 clause 5.5, where the required slab thicknesses by that standard are the same as those proposed for the given FRL.

Based on the above discussion, and in the absence of any foreseeable integrity weakness it is considered that the proposed construction will maintain integrity for up to 240 minutes when tested in accordance with AS 1530.4-2014 and assessed in accordance with AS 4072.1-2005 Amdt. 1.

#### ***Copper and Steel Pipes up to 150mm in diameter penetrating a minimum 150mm slab***

The proposed construction comprises 150mm diameter copper and steel pipes penetrating a 150mm thick with a minimum 50mm deep Fyreflex sealant in a 10mm - 20mm annular gap and with a minimum 20mm high x 50mm wide fillet of Fyreflex sealant on the unexposed side of the penetration.

With reference to FSP 0768 specimen B, the 150mm diameter copper pipe penetrated an 80mm thick Fyreset mortar support construction. It was protected with a 30mm depth of Fyreflex sealant in a 5mm

annular gap and a 20mm x 50mm Fyreflex sealant fillet on the unexposed side. The specimen did not fail integrity for 198 minutes duration of the test.

The proposed annular gap is slightly large than that tested in FSP 0768 specimen B, which may decrease the integrity performance of the seal around the copper pipe. However, with the increase in sealant depth to 50mm, it is expected that the extra moisture in the acrylic sealant will act to cool the pipe down and improve the integrity performance of the seal.

The proposed concrete slab has lower insulation performance per mm thickness than the tested Fyreset mortar. However, the proposed increase in slab thickness to a minimum of 150mm will act to maintain the insulation performance of the support construction and increase the overall depth, thus allowing the penetration seal to be cooler overall and reducing the exposure to the seal on the non-fireside.

Steel has a lower thermal conductivity than copper and when pipes are larger and thicker they will conduct more heat than a smaller and thinner pipe. Therefore, the result for FSP 0768 specimen B may be applied to copper and ferrous metal pipes having outside diameters not greater than the tested diameter, and copper pipes with a wall thickness not more than the tested thickness in the referenced test.

For steel pipes, the slight increase in wall thickness can be tolerated as it will balance out the less conductive nature of the steel pipe. On balance, it is expected that the proposed steel pipe will perform similar or better than the tested pipe in the referenced test.

Confidence in the ability of the concrete slab to perform for the required FRL is offered by reference to AS 3600-2018 clause 5.5, where the required slab thicknesses by that standard are the same as those proposed for the given FRL.

Based on the above discussion, and in the absence of any foreseeable integrity weakness it is considered that the proposed construction will maintain integrity for up to 180 minutes when tested in accordance with AS 1530.4-2014 and assessed in accordance with AS 4072.1 -2005 Amdt. 1.

#### ***Copper and Steel Pipes up to 150mm in diameter penetrating a minimum 120mm slab***

The proposed construction comprises 150mm diameter copper and steel pipes penetrating a 120mm thick slab with a minimum 30mm deep Fyreflex sealant in a 10mm - 20mm annular gap and with a minimum 20mm high x 50mm wide fillet of Fyreflex sealant on the unexposed side of the penetration.

With reference to FSP 0768 specimen A, the 150mm diameter copper pipe penetrated an 80mm thick Fyreset mortar support construction. It was protected with a 30mm depth of Fyreflex sealant in a 20mm annular gap and a 20x50mm Fyreflex sealant fillet on the unexposed side. The specimen did not fail integrity for 198 minutes duration of the test.

The proposed concrete slab has lower insulation performance per mm thickness than the tested Fyreset mortar. However, the proposed increase in slab thickness to a minimum of 120mm will act to maintain the insulation performance of the support construction and increase the overall depth, thus allowing the penetration seal to be cooler overall and allow the penetration seal to maintain integrity for longer.

Steel has a lower thermal conductivity than copper and when pipes are larger and thicker they will conduct more heat than a smaller and thinner pipe. Therefore, the result for FSP 0768 specimen A may be applied to copper and ferrous metal pipes having outside diameters not greater than the tested diameter, and copper pipes with a wall thickness not more than the tested thickness in the referenced test.

For steel pipes, the slight increase in wall thickness can be tolerated as it will balance out the less conductive nature of the steel pipe. On balance, it is expected that the proposed steel pipe will perform similar or better than the tested pipe in the referenced test.



Confidence in the ability of the concrete slab to perform for the required FRL is offered by reference to AS 3600-2018 clause 5.5, where the required slab thicknesses by that standard are the same as those proposed for the given FRL.

Based on the above discussion, and in the absence of any foreseeable integrity weakness it is considered that the proposed construction will maintain integrity for up to 120 minutes when tested in accordance with AS 1530.4-2014 and assessed in accordance with AS 4072.1 -2005 Amdt. 1.

#### ***Steel Pipes up to 115mm in diameter penetrating a minimum 175mm slab***

The proposed construction comprises 115mm diameter steel pipes penetrating a 175mm thick slab with a minimum 50mm deep Fyreflex sealant in a 10mm - 20mm annular gap and with a minimum 20mm high x 50mm wide fillet of Fyreflex sealant on the unexposed side of the penetration.

With reference to NI 1089 specimen C, the 114mm diameter steel pipe penetrated a 115mm thick concrete slab. It was protected with a 30mm depth of Fyreflex sealant in a 23mm annular gap and a 20x50mm Fyreflex sealant fillet on the unexposed side. The specimen did not fail integrity for 240 minutes duration of the test and failed insulation at 30 minutes into the test.

The proposed decrease in the annular gap will slightly improve the integrity performance of the seal around the penetration. Also, with the increase in sealant depth to 50mm, it is expected that the moisture in the acrylic sealant will act to cool the pipe down and improve the integrity performance of the seal.

The increase in slab thickness will also act to cool the pipe down and improve the performance of the seal around the pipe.

With reference to NI 1089 specimen C, the 114mm diameter steel extended 2000mm away from the furnace, which is much longer than the 500mm extension length allowed in AS 1530.4 -2014. The proposed construction would only have a 500mm extension and thus would be getting hotter at a faster rate than that tested in NI 1089 as there is now less metal to carry heat away on the unexposed side. Therefore, it is expected it will reach insulation failure sooner than 30 minutes.

Confidence in the ability of the concrete slab to perform for the required FRL is offered by reference to AS 3600-2018 clause 5.5, where the required slab thicknesses by that standard are the same as those proposed for the given FRL.

Based on the above discussion, and in the absence of any foreseeable integrity weakness it is considered that the proposed construction will maintain integrity and insulation for up to 240 minutes and 15 minutes respectively when tested in accordance with AS 1530.4-2014 and assessed in accordance with AS 4072.1 -2005 Amdt. 1.

#### ***Confirmation of aperture spacing***

AS 4072.1 -2005 Amdt. 1 clause 4.9.3 states that “the minimum distance between penetrations in a modular system shall be not less than 40 mm unless otherwise tested in specimen form.” It is noted also in clause 1.4.10 which defines a “penetration” as “An aperture through a fire-separating element for the passage of a service or services”

Based on the above, it is considered that AS 4072.1 -2005 Amdt. 1 clause 4.9.3 is applicable to the specimens considered in this assessment. The minimum aperture to aperture spacing of the proposed penetrations is thus 40mm.

## B.2 Variation to metal pipes in floors - with Twrap

The proposed construction comprises metal pipe penetrations in floors as tested in FRT180391 and FRT 190292.5 when subject to the following variations;

- Variation of slab thickness to 120mm where possible
- Change the gap around the pipe to be up to 20mm.
- Variations in sealant depth and fillet size as shown in Table B2a and B2b.
- Variations in pipe size and materials as shown in Table B2a and B2b.
- The separation of the specimens shall be at least 40mm refer to Figure 5b
- Wrap to be installed with overlap as per Figure 2-4

**Table B2a: Metal pipes in concrete slabs with Twrap**

Pipe material	Nominal pipe diameter OD (mm)	The gap between pipe and slab (mm)	Minimum Fyreflex sealant depth (mm)	Minimum Fyreflex sealant fillet size on the unexposed side (h x w) (mm)	Twrap on the unexposed side (mm) (2 <sup>nd</sup> layer)	Minimum concrete slab thickness (mm)
Copper	Up to DN50	10 -20	50	30 x 30	300	175
	Up to DN100	10 -20	60	30 x 30	750	120
		10 -20	60	30 x 30	800(300)	175
	Up to DN150	10 -20	50	30 x 30	850	175
Steel	Up to NB50	10 -20	50	30 x 30	300	175
	Up to NB100	10 -20	60	30 x 30	750	120
		10 -20	60	40 x 40	450 with unistrut	150
		10 -20	60	40 x 40	450 without unistrut	120
		10 -20	60	40 x 40	450 without unistrut	175
	Up to NB150	10 -20	50	30 x 30	600	175
		10 -20	50	30 x 30	600(300)	175

**Table B2b: Metal pipes in concrete slabs with Twrap**

Pipe material	Nominal pipe diameter OD	The gap around the pipe (mm)	Fyreflex sealant depth (mm)	Wrap length unexposed side	Slab thickness (mm)
Copper Type B	Up to DN50	10 -20	60	300	≥120
	Up to DN65			450	
	Up to DN100			600	
	Up to DN150			850	
Steel Medium Grade	Up to NB50			300	
	Up to NB150			600	

### **Copper and Steel Pipes up to 50mm in diameter penetrating a minimum 175mm slab**

The proposed construction comprises 50mm maximum diameter copper or steel pipes penetrating a minimum 175mm thick concrete slab with a minimum 50mm deep Fyreflex sealant in a 10mm - 20mm annular gap and with a minimum 30mm high x 30mm wide fillet of Fyreflex sealant and a 300mm length of Twrap on the unexposed side of the penetration.

With reference to FRT180391.1 specimen A, the 50mm diameter copper pipe penetrated a 175mm thick concrete slab and was protected with a 50mm depth of Fyreflex sealant in a 10mm annular gap



and a 15x15mm Fyreflex sealant fillet on the unexposed side. A 300mm length of Twrap protected the pipe on the unexposed side. When tested the specimen was able to maintain integrity for 241 minutes duration of the test and failed insulation at 143 minutes into the test.

Steel has a lower thermal conductivity than copper and when pipes are larger and thicker they will conduct more heat than a smaller and thinner pipe. Therefore, the result for FRT180391.1 specimen A may be applied to copper and ferrous metal pipes having outside diameters not greater than the tested diameter, and copper pipes with a wall thickness not more than the tested thickness in the referenced test.

For steel pipes, the slight increase in wall thickness can be tolerated as it will balance out the less conductive nature of the steel pipe. On balance, it is expected that the proposed steel pipe will perform similar or better than the tested pipe in the referenced test.

The increase in the annular gap is expected to increase the amount of heat flow into the annular gap, potentially heating up the sealant faster and may lead to a decrease in the integrity performance of the sealant seal.

However, the proposed fillet size is twice as large as the one tested in FRT180391.1 specimen A, which will provide a significant margin to the integrity performance of the seal.

Therefore, it is expected that the proposed increase in the annular gap in conjunction with the larger fillet will not detrimentally affect the integrity performance of FRT180391.1 specimen A for up to 120 minutes.

Confidence in the ability of the concrete slab to perform for the required FRL is offered by reference to AS 3600-2018 clause 5.5, where the required slab thicknesses by that standard are the same as those proposed for the given FRL.

Based on the above, it is expected that the proposed construction will be able to maintain integrity and insulation for up to 120 minutes when tested in accordance with AS 1530.4-2014 and assessed in accordance with AS 4072.1 -2005 Amdt. 1.

#### ***Copper and Steel Pipes up to 50mm in diameter penetrating a minimum 120mm slab***

The proposed construction comprises 50mm maximum diameter copper or steel pipes penetrating a minimum 120mm thick concrete slab with a minimum 60mm deep Fyreflex sealant in a 10mm - 20mm annular gap and with a minimum 30mm high x 30mm wide fillet of Fyreflex sealant and a 300mm length of Twrap on the unexposed side of the penetration.

With reference to FRT180391.1 specimen A, the 50mm diameter copper pipe penetrated a 175mm thick concrete slab and was protected with a 50mm depth of Fyreflex sealant in a 10mm annular gap and a 15x15mm Fyreflex sealant fillet on the unexposed side. A 300mm length of Twrap protected the pipe on the unexposed side. When tested the specimen was able to maintain integrity for 241 minutes duration of the test and failed insulation at 143 minutes into the test.

As discussed above, the proposed increase in the annular gap will be balanced out by the proposed increase in fillet size. The increase in sealant depth will improve the integrity performance of the seal.

The proposed slab is 50mm thinner than the 175mm slab tested and would thus have less heat sink effect. However, given the 53 minutes margin on insulation and 151 minutes margin on integrity, it is expected that the proposed specimen would be able to maintain integrity and insulation for up to 90 minutes.

Confidence in the ability of the concrete slab to perform for the required FRL is offered by reference to AS 3600-2018 clause 5.5, where the required slab thicknesses by that standard are the same as those proposed for the given FRL.

Based on the above discussions, it is expected that the proposed construction will be able to maintain integrity and insulation for up to 90 minutes when tested in accordance with AS 1530.4-2014 and assessed in accordance with AS 4072.1 -2005 Amdt. 1.

### ***Copper and Steel Pipes up to 100mm in diameter penetrating a minimum 120mm slab***

The proposed construction comprises 100mm maximum diameter copper and steel pipes penetrating a minimum 120mm thick concrete slab, with a minimum 60mm deep Fyreflex sealant in a 10mm - 20mm annular gap and with a minimum 30mm high x 30mm wide fillet of Fyreflex sealant and a Twrap length of 750mm on the unexposed side of the penetration.

With reference to FRT 190292.5 specimen E2, the 100mm diameter copper pipe penetrated a 60mm thick Maxilite panel and was protected with a 60mm depth of Fyreflex sealant in a 19mm annular gap and a 30mm x 30mm Fyreflex sealant fillet on the unexposed side. An 800mm length of Twrap protected the pipe on the unexposed side and when tested specimen failed integrity at 214 minutes and failed insulation on the Twrap at 150 minutes. The Maxilite barrier failed insulation at 189 minutes and the pipe failed at 212 minutes.

The proposed 750mm Twrap length is 50mm shorter than tested. A shorter length of Twrap will allow the unexposed face pipe thermocouples to read a higher temperature on the unexposed side. The 1mm increase in the maximum allowed annular gap will also allow slightly more heat to enter the annular gap and heat the sealant fast leading to earlier integrity failure of the seal.

However, the proposed concrete slab has a higher insulation performance per mm thickness than the tested 60mm Maxilite. Also, the proposed 120mm slab allows for a greater conduction path of the pipe from the exposed face to the unexposed face. Both of these factors will assist in the insulation and integrity performance of the specimen.

On balance, it is expected that the proposed variations will not detriment the integrity and insulation performance of FRT 190292.5 specimen E2 for up to 120 minutes.

Steel has a lower thermal conductivity than copper and when pipes are larger and thicker they will conduct more heat than a smaller and thinner pipe. Therefore, the result for FRT 190292.5 specimen E2 may be applied to copper and ferrous metal pipes having outside diameters not greater than the tested diameter, and copper pipes with a wall thickness not more than the tested thickness in the referenced test.

For steel pipes, the slight increase in wall thickness will balance out the less conductive nature of the steel pipe. On balance, it is expected that the proposed steel pipe will perform similar or better than the tested pipe in the referenced test.

Based on the above, the result for FRT 190292.5 specimen E2 is applicable to all copper and steel pipes up to 100mm in diameter.

Confidence in the ability of the concrete slab to perform for the required FRL is offered by reference to AS 3600-2018 clause 5.5, where the required slab thicknesses by that standard are the same as those proposed for the given FRL.

Based on the above, it is expected that the proposed construction will be able to maintain integrity and insulation for up to 120 minutes when tested in accordance with AS 1530.4-2014 and assessed in accordance with AS 4072.1 -2005 Amdt. 1.

### ***Copper Pipes up to 100mm in diameter penetrating a minimum 150mm slab***

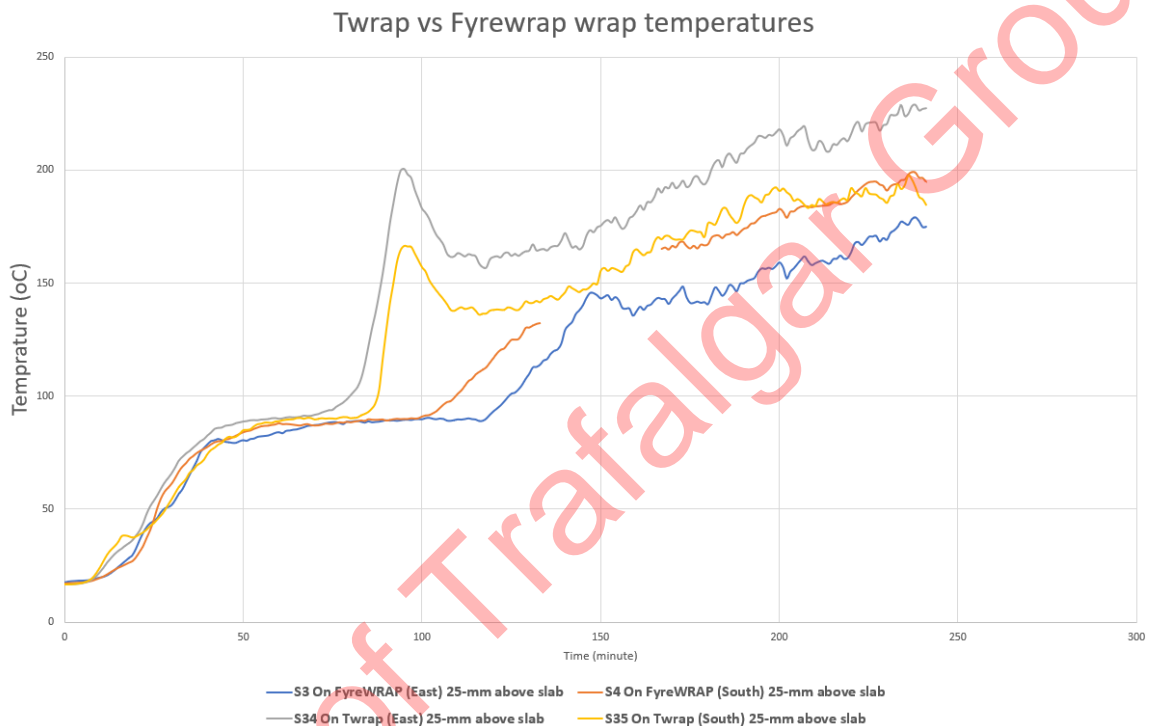
The proposed construction comprises 100mm maximum diameter copper pipes penetrating a minimum 150mm thick concrete slab, with a minimum 60mm deep Fyreflex sealant in a 10mm - 20mm annular gap and with a minimum 30mm high x 30mm wide fillet of Fyreflex sealant and 600mm length of Twrap on the unexposed side of the penetration.

With reference to FSP 2146 specimen 1, where a 100mm diameter copper pipe was protected with 60mm deep Fyreflex sealant and 30mm fillets as well as wrapped with 600mm length of Fyrewrap on the unexposed side. Specimen failed insulation at 133 minutes and failed integrity at 142 minutes when the pipe was burnt through, allowing venting to occur.

With reference to FSP 2146 specimen 4, where a 100mm diameter copper pipe was protected with 60mm deep Fyreflex sealant and 30mm fillets as well as wrapped with 600mm length of Twrap on the unexposed side. Specimen failed insulation at 82 minutes and failed integrity at 92 minutes when the pipe was burnt through, allowing venting to occur.

The burnt through of the copper pipe was due to localised hot spots in the furnace as in FRT 190292.5 specimen E2, it is shown that a 100mm diameter copper pipe unprotected on the underside can maintain integrity without venting for up to 214 minutes.

FSP 2146 specimens 1 and 4 were designed to compare the performance of Fyrewrap and Twrap. The 100mm copper pipe was used as the heating element under these wraps. Therefore, by disregarding the burnt through of the pipe, the pipe temperature, and the different wrap temperatures can be examined to determine the performance of the penetrations in this case.



**Figure B1: Wrap temperatures in FSP 2146**

With reference to Figure B1, prior to these pipes fluing, the insulation performance of the wraps was similar, with Twrap heating up slightly faster than Fyrewrap before they both plateaued in temperature rise to just under 100°C at around 50 minutes. During the fluing of the pipes, it was observed that Twrap also heated up faster than Fyrewrap as shown by the steeper gradient of the Twrap temperature peak. After fluing of the pipes, the Twrap and Fyrewrap temperature rise was again similar.

Therefore, it is reasonable and conservative to expect that if FSP 2146 specimen 1 had its copper pipe wrapped with Twrap, it would have also performed similarly to or just marginally worse than specimen 1 for up to 180 minutes.

Despite the cap melting of the fireside cap for FSP 2146 specimen 1 which comprised 100mm copper pipe with 600mm Fyrewrap, the specimen was able to maintain insulation for 133 minutes. Based on the above it is considered on balance of the performance of each wrap and the margin performance at 120 minutes for Fyrewrap, it is considered that if the copper pipe tested in FSP 2146 Specimen 1 was wrapped with Twrap, it would be able to maintain insulation for up to 120 minutes.

Based on the above, it is expected that the proposed construction will be able to maintain integrity and insulation for up to 120 minutes when tested in accordance with AS 1530.4-2014 and assessed in accordance with AS 4072.1 -2005 Amdt. 1.

### ***Copper Pipes up to 100mm in diameter penetrating minimum 120mm slab***

The proposed construction comprises 100mm maximum diameter copper pipes penetrating a minimum 120mm thick concrete slab, with a minimum 60mm deep Fyreflex sealant in a 10mm - 20mm annular gap and with a minimum 30mm high x 30mm wide fillet of Fyreflex sealant and 600mm length of Twrap on the unexposed side of the penetration.

With reference to FSP 2146 specimen 1, a 100mm diameter copper pipe was protected with 60mm deep Fyreflex sealant and 30mm fillets as well as wrapped with a 600mm length of Fyrewrap on the unexposed side of a 150mm slab. Specimen failed insulation at 133 minutes and failed integrity at 142 minutes when the pipe was burnt through, allowing venting to occur.

The proposed slab is 30mm thinner than the 150mm slab tested and would thus have less heat sink effect. However, given the 43 minutes margin on insulation and 52 minutes margin on integrity, it is expected that the proposed specimen would be able to maintain integrity and insulation for up to 90 minutes.

Confidence in the ability of the concrete slab to perform for the required FRL is offered by reference to AS 3600-2018 clause 5.5, where the required slab thicknesses by that standard are the same as those proposed for the given FRL.

Based on the above, it is expected that the proposed construction will be able to maintain integrity and insulation for up to 90 minutes when tested in accordance with AS 1530.4-2014 and assessed in accordance with AS 4072.1 -2005 Amdt. 1.

### ***Copper and Steel Pipes up to 65mm in diameter penetrating a minimum 120mm slab***

The proposed construction comprises a 50mm maximum diameter copper pipe penetrating a minimum 120mm thick concrete slab with a minimum 60mm deep Fyreflex sealant in a 10mm - 20mm annular gap and with a minimum 30mm high x 30mm wide fillet of Fyreflex sealant and a 450mm length of Twrap on the unexposed side of the penetration.

The above discussion demonstrated that a 50mm copper pipe with a 300mm Twrap on the unexposed side and a 100mm copper with a 600mm Twrap on the unexposed side can both maintain integrity and insulation for up to 90 minutes.

DN65 copper pipe has the same pipe thickness as the DN50 copper pipe, except it is just under 30% larger in diameter. A calculation was undertaken and it was confirmed that the proposed 150mm increase in wrap length will be sufficient to compensate for the increase in diameter such that the pipe will be able to maintain insulation for up to 90 minutes.

Based on the above, it is expected that the proposed construction will be able to maintain integrity and insulation for up to 90 minutes when tested in accordance with AS 1530.4-2014 and assessed in accordance with AS 4072.1 -2005 Amdt. 1.

### ***Copper Pipes up to 100mm in diameter penetrating minimum 175mm slab***

The proposed construction comprises 100mm maximum diameter copper pipes penetrating a minimum 175mm thick concrete slab, with a minimum 60mm deep Fyreflex sealant in a 10mm - 20mm annular gap and with a minimum 30mm high x 30mm wide fillet of Fyreflex sealant and an additional 300mm length of Twrap on top of the existing 800mm length of Twrap on the unexposed side of the penetration.

The proposed construction is similar to the construction discussed above. The difference being the proposed construction has an additional layer of Twrap which will allow the Twrap thermocouple located 25mm from the penetration to maintain insulation for at least another 30 minutes.

The increase in barrier thickness from the tested 60mm Maxilite panel to the 175mm concrete slab will also improve the Twrap and pipe insulation performance in allowing for a greater conduction path

between the furnace and the thermocouple on the unexposed side as well as concrete slab providing a heat sink effect.

Confidence in the ability of the concrete slab to perform for the required FRL is offered by reference to AS 3600-2018 clause 5.5, where the required slab thicknesses by that standard are the same as those proposed for the given FRL.

Based on the above discussions, it is expected that the proposed construction will be able to maintain integrity and insulation for up to 180 minutes when tested in accordance with AS 1530.4-2014 and assessed in accordance with AS 4072.1 -2005 Amdt. 1.

#### ***NB100 Steel Pipes penetrating a minimum 120mm slab***

The proposed construction comprises NB100 steel pipes penetrating a minimum 120mm thick concrete slab, with a minimum 60mm deep Fyreflex sealant in a 10mm - 20mm annular gap and with a minimum 40mm high x 40mm wide fillet of Fyreflex sealant and 450mm length of Twrap on the unexposed side of the penetration, without Unistrut pipe clamp system.

With reference to FSP 2146 specimen 1, the NB100m steel pipe helped by the Unistrut pipe clamp system penetrated a 150mm thick slab and was protected on the unexposed side with a 450mm length of Twrap. The specimen did not fail integrity for 241 minutes and failed insulation at 126 minutes on the Unistrut pipe clamp system. The pipe measured a temperature rise of 106oK at 120 minutes and 131oK at 180 minutes.

The proposed 120mm slab is thinner and thus has less thermal mass than the tested 150mm thick slab. However, given the low temperature of the pipe, it is expected that the specimen will not have a temperature rise of greater than 180°K at 120 minutes when installed in a 120mm thick slab.

The proposed 175mm slab is thicker and thus has more thermal mass than the tested 150mm thick slab. It is expected that the specimen will not have a temperature rise of greater than 180°K at 180 minutes when installed in a 175mm thick slab.

Confidence in the ability of the concrete slab to perform for the required FRL is offered by reference to AS 3600-2018 clause 5.5, where the required slab thicknesses by that standard are the same as those proposed for the given FRL.

Based on the above discussions, it is expected that the proposed 120mm, 150mm thick slab will be able to maintain integrity and insulation for up to 120 minutes and the proposed 175mm thick slab will be able to maintain integrity and insulation for up to 180 minutes when tested in accordance with AS 1530.4-2014 and assessed in accordance with AS 4072.1 -2005 Amdt. 1.

#### ***Copper Pipes up to 150mm in diameter penetrating minimum 175mm slab***

The proposed construction comprises 150mm maximum diameter copper pipes penetrating a minimum 175mm thick concrete slab, with a minimum 50mm deep Fyreflex sealant in a 10mm - 20mm annular gap and with a minimum 30mm high x 30mm wide fillet of Fyreflex sealant and 850mm length of Twrap on the unexposed side of the penetration.

With reference to FRT180391.1 specimen B, the 150mm diameter copper pipe penetrated a 175mm thick concrete slab and was protected with a 50mm depth of Fyreflex sealant in a 10mm annular gap and a 15x15mm Fyreflex sealant fillet on the unexposed side. A 700mm length of Twrap protected the pipe on the unexposed side. The specimen failed integrity at 171 minutes and failed insulation at 70 minutes on the pipe.

As discussed above, the proposed increase in the annular gap will be balanced out by the proposed increase in fillet size.

The pipe at 120 minutes measured a rise in temperature of 211°C. With the additional 150mm length of Twrap on the unexposed side, it is expected that the pipe will maintain insulation for 120 minutes.

Confidence in the ability of the concrete slab to perform for the required FRL is offered by reference to AS 3600-2018 clause 5.5, where the required slab thicknesses by that standard are the same as those proposed for the given FRL.

Based on the above discussions, it is expected that the proposed construction will be able to maintain integrity and insulation for up to 120 minutes when tested in accordance with AS 1530.4-2014 and assessed in accordance with AS 4072.1 -2005 Amdt. 1.

#### ***Steel Pipes up to 150mm in diameter penetrating minimum 175mm slab***

The proposed construction comprises 150mm maximum diameter steel pipes penetrating a minimum 175mm thick concrete slab, with a minimum 50mm deep Fyreflex sealant in a 10mm - 20mm annular gap and with a minimum 30mm high x 30mm wide fillet of Fyreflex sealant and an additional 300mm length of Twrap on top of the existing 600mm length of Twrap on the unexposed side of the penetration,

With reference to FRT 190292.5, specimen G comprises a 152.4mm OD x 5.3mm thick steel pipe penetrating a 175mm thick concrete slab protected on the unexposed side by 50mm depth of Fyreflex in a 10mm annular gap and finished off with a 30mm x 30mm of Fyreflex fillet. The pipe was then wrapped in a 600mm length of Twrap. The specimen maintain integrity for 241 minutes and failed insulation at 170 minutes on the wrap. The pipe failed insulation at 207 minutes.

The proposed construction is similar to the construction discussed above. The difference being the proposed construction has an additional layer of Twrap which will allow the Twrap thermocouple located 25mm from the penetration to maintain insulation for at least another 30 minutes.

Confidence in the ability of the concrete slab to perform for the required FRL is offered by reference to AS 3600-2018 clause 5.5, where the required slab thicknesses by that standard are the same as those proposed for the given FRL.

Based on the above discussions, it is expected that the proposed construction will be able to maintain integrity for up to 240 minutes and insulation for up to 180 minutes when tested in accordance with AS 1530.4-2014 and assessed in accordance with AS 4072.1 -2005 Amdt. 1.

#### ***Copper Pipes up to 150mm in diameter penetrating minimum 120mm slab***

The proposed construction comprises 150mm maximum diameter copper pipes penetrating a minimum 120mm thick concrete slab, with a minimum 60mm deep Fyreflex sealant in a 10mm - 20mm annular gap and with a minimum 30mm high x 30mm wide fillet of Fyreflex sealant and 850mm length of Twrap on the unexposed side of the penetration,

With reference to FRT180391.1 specimen B, the 150mm diameter copper pipe penetrated a 175mm thick concrete slab and was protected with a 50mm depth of Fyreflex sealant in a 10mm annular gap and a 15x15mm Fyreflex sealant fillet on the unexposed side. A 700mm length of Twrap protected the pipe on the unexposed side. The specimen failed integrity at 171 minutes and failed insulation at 70 minutes on the pipe. The pipe at 90 minutes measured a rise in temperature of 198°C.

As discussed above, the proposed increase in the annular gap will be balanced out by the proposed increase in fillet size. The increase in sealant depth will improve the integrity performance of the seal.

The proposed 120mm slab is thinner and thus has less thermal mass than the tested 175mm thick slab. However, the proposed additional 150mm length of Twrap on the unexposed side will allow for a greater conduction path to the unexposed side.

On balance, it is expected that the proposed specimen would be able to maintain integrity and insulation for up to 90 minutes.

Confidence in the ability of the concrete slab to perform for the required FRL is offered by reference to AS 3600-2018 clause 5.5, where the required slab thicknesses by that standard are the same as those proposed for the given FRL.



Based on the above discussions, it is expected that the proposed construction will be able to maintain integrity and insulation for up to 90 minutes when tested in accordance with AS 1530.4-2014 and assessed in accordance with AS 4072.1 -2005 Amdt. 1.

**Steel Pipes up to 150mm in diameter penetrating a minimum 120mm slab**

The proposed construction comprises 150mm maximum diameter steel pipes penetrating a minimum 120mm thick concrete slab, with a minimum 60mm deep Fyreflex sealant in a 10mm - 20mm annular gap and with a minimum 30mm high x 30mm wide fillet of Fyreflex sealant and an additional 300mm length of Twrap on top of the existing 600mm length of Twrap on the unexposed side of the penetration.

With reference to FRT 190292.5, specimen G comprises a 152.4mm OD x 5.3mm thick steel pipe penetrating a 175mm thick concrete slab protected on the unexposed side by 50mm depth of Fyreflex in a 10mm annular gap and finished off with a 30mm x 30mm of Fyreflex fillet. The pipe was then wrapped in a 600mm length of Twrap. The specimen maintained integrity for 241 minutes and failed insulation at 170 minutes on the wrap. The pipe failed insulation at 207 minutes.

The proposed 120mm slab is thinner and thus has less thermal mass than the tested 175mm thick slab. However, given the 117 minutes margin on the pipe insulation performance and 80 minutes margin on the wrap insulation performance, it is expected that the proposed penetration will be able to maintain insulation for up to 90 minutes.

Confidence in the ability of the concrete slab to perform for the required FRL is offered by reference to AS 3600-2018 clause 5.5, where the required slab thicknesses by that standard are the same as those proposed for the given FRL.

Based on the above discussions, it is expected that the proposed construction will be able to maintain integrity and insulation for up to 90 minutes when tested in accordance with AS 1530.4-2014 and assessed in accordance with AS 4072.1 -2005 Amdt. 1.

**Stainless steel pipes penetrating a floor**

The proposed construction comprises up to 54mm and up to 170mm maximum diameter stainless steel pipes penetrating a minimum 120mm thick concrete floor slab, with a minimum 60mm deep Fyreflex sealant in a 10mm - 20mm annular gap and with a minimum 30mm high x 30mm wide fillet of Fyreflex sealant and protected with various length of Twrap on the unexposed side of the penetration as shown in Table B2c.

**Table B2c: Proposed Stainless steel pipes in concrete slabs with Twrap**

Stainless-steel pipe	The gap around the pipe (mm)	Fyreflex sealant depth (mm)	Fyreflex sealant fillet size (h x w) (mm)	Twrap, Mono-wrap or Fyrewrap length above the slab (mm)	Twrap, Fyrewrap length above the slab (mm)	Slab thickness (mm)
Up to 54mm OD and a minimum 1.5mm wall thickness	10-20	60	30 x 30	300	NA	120
				450	NA	
				NA	300	150
						175
Up to 170mm OD and a minimum 1.5mm wall thickness	10-20	60	30 x 30	600	NA	150
				2 x 800	NA	120
				800(300)	NA	150
				NA	2 x 800	150
						175

With reference to FSP 2317, 54mm and 170mm stainless steel pipes penetrated a 150mm thick concrete slab and were protected on the top side with Twrap and sealant. The summary of these specimens is as per Table B2d below.

**Table B2d: Test summary of stainless steel pipes in concrete slabs with Twrap**

Test specimen	Support construction	Fyreflex Depth (mm)	Annular gap (mm)	Fillet on Unexp. side (H x W) (mm)	Twrap Unexp. side (mm)	Pipe	Performance (min.)
FSP 2317	150mm concrete slab	60	8-18	20 x 30	300mm Twrap	54mm x 1.5mm stainless steel	-/241NF/241NF
FSP 2317	150mm concrete slab	60	5-25	30 x 30	600mm Twrap	170mm x 1.5mm stainless steel	-/241NF/95 (on pipe, 101 on wrap)

*54mm stainless steel pipe penetrating a floor*

The proposed variation includes the 54mm stainless steel pipe as tested in FSP 2317 specimen 5 being installed in 120mm thick slabs with either the same wrap length or with a longer wrap length and sealed with a slightly larger fillet of sealant.

It is expected that when installed with the same wrap length, the reduction in slab thickness will result in earlier insulation failure. With a large margin in insulation performance, it is expected that the proposed construction will be able to maintain integrity and insulation for up to 90 minutes.

It is expected that when installed with a 450mm long wrap length, the increase in the conduction path will balance out the reduction in slab thickness. With 120 minutes of margin in insulation performance, it is expected that the proposed construction will be able to maintain integrity and insulation for up to 120 minutes.

The proposed variation includes the 54mm stainless steel pipe as tested in FSP 2317 specimen 5 being installed in 150mm and 175mm thick slabs with either the same wrap length as tested and sealed with a slightly larger fillet of sealant.

It is expected that the increased fillet size will improve the integrity performance of the pipe at the penetration seal while a thicker slab will improve the insulation performance of the pipe.

Based on the above, it is expected that the proposed construction will be able to maintain integrity and insulation for up to 180 and 240 minutes based on the design.

*170mm stainless steel pipe penetrating a floor*

The proposed variation includes the 170mm stainless steel pipe as tested in FSP 2317 specimen 6 being installed in 120mm, 150mm and 175mm thick slabs with a longer wrap length as well as an additional second layer of wrap at the same length.

It is expected that the 200mm additional wrap length will result in an increase in the conduction path that will act to reduce the heat sink effect due to the reduction in slab thickness for the 120mm slab. The additional layer of wrap will also allow the wrap 25mm from the slab to maintain insulation for up to 240 minutes. Based on a calculation of the pipe temperature gradient, it is expected that the proposed construction will be able to maintain integrity and insulation for up to 120, 180 and 240 minutes based on design.



The proposed variation includes the 170mm stainless steel pipe as tested in FSP 2317 specimen 6 being installed in 150mm thick slabs with either the same wrap length or in a 120mm slab though with a longer wrap length as well as an additional second layer of 300mm wrap.

FSP 2317 specimen 6 demonstrated that the 170mm stainless steel pipe was able to maintain insulation on the pipe and wrap for up to 90 minutes.

When the slab is reduced to 120mm, it is expected that the 200mm additional wrap length will result in an increase in the conduction path that will act to reduce the heat sink effect due to the reduction in slab thickness for the 120mm slab. The additional second layer of 300mm wrap will also allow the 2<sup>nd</sup> layer of wrap 25mm from the slab and 1<sup>st</sup> layer of wrap at 25mm from the second layer of wrap to maintain insulation for up to 120 minutes.

Based on the above discussions, it is expected that the proposed construction will be able to maintain integrity and insulation for up to 90, 120, 180 and 240 minutes based on design when tested in accordance with AS 1530.4-2014 and assessed in accordance with AS 4072.1 -2005 Amdt. 1.

### B.3 Variation to metal pipes in walls - with Twrap

The proposed construction comprises metal pipes tested in FRT 180392.1, FP 6033, FP 6372, FSP 1753, FRT 190298 R1.1, and FP11935-001. FRT 200160.2, FRT200397 R1.2 when subject to the following variations:

- Variations in pipe size and materials as shown in Table 2.
- The gap between the pipe and wall opening is to be a maximum of 10mm.
- Fyreflex size to be based on design.
- Variation of wrap length based on design.
- Variation to wall type and inclusion of a localised wall thickening.
- Wrap to be installed with overlap as per Figure 9-11.
- The separation of the specimens shall be at least 40mm refer to Figure 5b

#### ***Copper and steel pipes up to 150mm in diameter penetrating plasterboard lined stud walls.***

The proposed construction comprises copper and steel pipes up to 150mm in diameter penetrating plasterboard lined walls with various lengths of Twrap and fillet sizes.

With reference Table B3a, it shows the test results of various metal pipe penetrating plasterboard lined walls.

**Table B3a: Metal pipes in plasterboard lined walls with Twrap**

Test specimen	Support construction	Depth of Fyreflex (mm)	Annular gap (mm)	Fillet on Unexp side (H x W) (mm)	Twrap Unexposed side (mm)	Protected Pipe	Integrity (min.)	Insulation (min.)
FRT 180392.1 (A)	116mm Plasterboard lined stud wall	26+26	7	15 x 15	350 (overlap of wrap)	50 x 1.22mm copper pipe	130NF	130NF
FRT 180392.1 (B)	116mm Plasterboard lined stud wall	26+26	7	15 x 15	300 (no overlap of wrap)	50 x 1.22mm copper pipe	130NF	116 (wrap)
FRT 180392.1 (D)	116mm Plasterboard lined stud wall	26+26	9	10 x 10	500	101.6mm x 1.63mm copper pipe	130NF	95 (pipe)

Test specimen	Support construction	Depth of Fyreflex (mm)	Annular gap (mm)	Fillet on Unexp side (H x W) (mm)	Twrap Unexposed side (mm)	Protected Pipe	Integrity (min.)	Insulation (min.)
FRT 180392.1 (F)	116mm Plasterboard lined stud wall	26+26	4	15 x 15	400	114.6mm x 4.58mm Steel pipe	130NF	130NF
FP 6033 (9)	90mm plasterboard wall	13+13	5	50 x 50	300	100mm x 1.7mm copper pipe	92NF	50 (pipe) 67 (wall)
FRT 180392.1 (H)	116mm Plasterboard lined stud wall	26+26	10	15 x 15	800	152.4 x 2.03mm copper pipe	130NF	51 (pipe) 110 (wrap) 118 (wall)
FP 11935-001(2)	60mm Blue Maxilite	60	10	50 x 50	2 layers of 420mm wrap on the fireside and 1100mm non-fireside with an additional 300mm 2nd layer of wrap	150mm x 1.8mm copper pipe	180NF	104 (Maxilite) 137 (wrap)
FRT 190292.5 (G)	175mm concrete slab	50	10	30 x 30	600	152.4 x 5.3mm steel pipe	241	170

### ***Twrap configurations***

With reference to the results of FRT 180392.1 specimen A and B, it was observed that the failure of Specimen B Twrap was due to the lack of overlap of Twrap and thus resulted in leakage of furnace gas from the Twrap. If specimen B had a Twrap overlap, it is expected that the wrap and the specimen would have maintained insulation for up to 120 minutes.

With the exception of a 150mm copper pipe, all the other specimens shown in Table B3a demonstrated that a single layer of Twrap was sufficient for maintaining insulation of 100mm diameter copper and 150mm diameter steel pipes for up to 120 minutes.

The proposed additional layer of Twrap on FRT 180392.1 specimen H appeared to provide at least 30 minutes of insulation performance and allow the Twrap to maintain insulation for at least 120 minutes.

This confidence is provided by FP 11935-001 specimen 2, where the 150mm pipe with 2 layers of 420mm Twrap on the fireside and 1100mm length of Twrap with an additional 300mm 2<sup>nd</sup> layer of Twrap on non-fireside, failed insulation on the Twrap at 137 minutes.

Therefore, it is expected that when copper and steel pipes with diameters up to 150mm are wrapped in two layers of Twrap, and penetrating plasterboard walls, it will maintain insulation on the Twrap for up to 120 minutes.

### ***Sealant variations***

The proposed variation also comprises fillet size that is either the same or much larger than that in the referenced tests in Table B3a for pipes under 150mm. No flaming integrity failure has been observed in relation to the failure of sealant for up to 120 minutes, and any possible furnace gas breach at the

sealant in the annular gap is protected by Twrap around the pipe. Therefore, it is expected that the proposed slight increase in the annular gap to 10mm will not detrimentally affect the integrity or insulation performance of 150mm diameter copper and steel pipes for up to 120 minutes.

The proposed variation also comprises a plasterboard wall with a thickness from 90mm to 116mm. This would result in a sealant depth of either the same as that tested in the referenced tests or slightly more in the case of 2 x 16mm fire rated plasterboard lined stud walls. The referenced tests all demonstrated the ability to maintain integrity at the seal for up to 90 minutes for 90mm thick plasterboard walls, and 130 minutes for 116mm thick plasterboard walls. Therefore, it is confident that the proposed 96mm plasterboard lined will be able to maintain integrity for at least 90 minutes at the penetration seal.

With reference to the results for FRT 180392.1 specimen H where an insulation failure on the 116mm thick plasterboard lined the wall occurred at 118 minutes. This was attributed to heat radiating from the 150mm copper pipe which heated up the plasterboard cavity, resulting in earlier barrier relational failure. The proposed increase in Twrap length on each side of the wall will decrease the heat absorbed by the copper pipe on the fireside, and thus decrease the temperature of the pipe in the wall and thereby the radiation emitted in the wall cavity. Such a variation is considered sufficient to increase the insulation performance of the wall a further 2 minutes.

### ***Pipe temperatures***

Having addressed the localised integrity failure at the penetration seal and the insulation failure of the Twrap and the wall barrier for pipes up to 150mm, the only variable to be addressed regarding the insulation performance of the proposed pipe penetrations is the temperature of the pipe. This will be discussed below.

### ***Insulation of up to DN50 Copper pipes and NB50 Steel pipes***

The proposed construction comprises copper pipes up to DN50 and steel pipes up to NB50 penetrating 90mm, 96mm and 116mm thick plasterboard line walls with 300mm Twrap on each side.

With reference to the results of test FRT 180392.1 Specimen B, the 50 x 1.22mm copper pipe temperature rise was 143°K at 120 minutes.

The proposed wall thicknesses are 20-26mm less than the tested wall thickness, which may result in a higher temperature rise for the pipe on the unexposed side due to a decrease in the conduction path for the proposed construction. However, the exposure to the pipe at 60 minutes and 90 minutes is much less than that at 120 minutes. Even at 120 minutes, the copper pipe had a 37°C margin on insulation performance.

Steel pipe is less conductive than copper pipes. Also, a large thick metal pipe will conduct more heat than a smaller and thinner pipe. Therefore, the result for FRT 180392.1 B may be applied to copper and ferrous metal pipes having outside diameters not greater than the tested diameter, and copper pipes with a wall thickness not more than the tested thickness in the referenced test.

For steel pipes, the slight increase in wall thickness can be tolerated as it will balance out the less conductive nature of the steel pipe. On balance, it is expected that the proposed steel pipe will perform similar or better than the tested pipe in the referenced test.

On balance, it is expected that the proposed construction will achieve an FRL of -/60/60, -/90/90 and -/120/120 when installed in minimum 90mm, 96mm or 116mm thick plasterboard lined stud walls as shown in Tables B4 and B5 below when tested in accordance with AS 1530.4 – 2014 and assessed in accordance with AS 4072.1 -2005.

### ***Insulation of up to DN100 Copper pipes***

The proposed construction comprises Copper pipes up to DN100 installed in 90mm thick plasterboard line walls protected with 450mm Twrap on each side and in 96mm and 116mm thick plasterboard line walls protected with 600mm Twrap on each side.

With reference to FP 6033 Specimen 9, the 100mm Copper pipe with 300mm Twrap on each side of the 90mm thick plasterboard wall measured 202°K temperature rise on the pipe at 60 minutes and 255°K at 90 minutes.

With reference to FRT 180392.1 Specimen D, the 100mm Copper pipe with 500mm Twrap on each side of the 116mm thick plasterboard wall measured 197°K temperature rise on the pipe at 120 minutes.

With the proposed increase in wrap length, the conduction path will also increase between the furnace side and the unexposed side. Therefore, it is expected that the temperature rise measured on the pipe on the unexposed side will decrease.

On balance, it is expected that the proposed construction will achieve an FRL of -/60/60, -/90/90 and -/120/120 when installed in minimum 90mm, 96mm and 116mm thick plasterboard lined stud walls as shown in Tables B4 and B5 below when tested in accordance with AS 1530.4 – 2014 and assessed in accordance with AS 4072.1 -2005.

#### ***Insulation of up to DN100 Steel pipes***

The proposed construction comprises steel pipes up to DN100 installed in 90mm, 96mm and 116mm thick plasterboard line walls protected with 400mm Twrap on each side

With reference to FRT 180392.1 Specimen H, the 114 mm Steel pipe with 400mm Twrap on each side of the 116mm thick plasterboard wall measured 159°K temperature rise on the pipe at 120 minutes.

The proposed wall thicknesses are 20-26mm less than the tested wall thickness, which will result in a higher temperature reading on the pipe on the unexposed side due to a decrease in the conduction path.

However, the furnace severity experienced by the pipe at 60 minutes and 90 minutes is much less than that at 120 minutes. Even at 120 minutes, the steel pipe had a 21°C margin on insulation performance.

On balance, it is expected that the proposed construction will achieve an FRL of -/60/60, -/90/90 and -/120/120 when installed in minimum 90mm, 96mm and 116mm thick plasterboard lined stud walls as shown in Tables B4 and B5 below when tested in accordance with AS 1530.4 – 2014 and assessed in accordance with AS 4072.1 -2005.

#### ***Insulation of up to DN150 Copper pipes***

The proposed construction comprises copper pipes up to DN150 installed in 116mm thick plasterboard line walls protected with 1100mm of Twrap on each side and with an additional layer of 300mm Twrap on each side.

With reference to FRT 180392.1 specimen H, the 150mm copper pipe with 800mm Twrap on each side of the wall measured 217°K temperature rise on the pipe at 90 minutes and 228°C at 120 minutes.

With the proposed increase in wrap length, the conduction path will also increase between the furnace side and the unexposed side. It is expected that the temperature rise measured on the pipe on the unexposed side will be less than that tested.

Based on the above, it is expected that the proposed construction will achieve an FRL of -/120/120 when installed in a minimum 116mm thick plasterboard lined stud walls as shown in Tables B4 and B5 below when tested in accordance with AS 1530.4 – 2014 and assessed in accordance with AS 4072.1 - 2005.

#### ***Insulation of up to NB150 Steel pipes***

The proposed construction comprises steel pipes up to NB150 installed in plasterboard line walls protected with 600mm of Twrap on each side.

With reference to FRT200397 R1.2 specimen 10, a 150mm x 4.9mm steel pipe penetrated a 120 mm thick batt system and was protected on each side with a 50mm x 50mm fillet of sealant. The fireside

was wrapped with a 300mm length of Twrap while the non-fireside was wrapped with a 450mm length of Twrap. The pipe failed insulation at 119 minutes.

The proposed variation would include increases in the wrap length and a slight decrease in wall thickness. On balance, it is expected that the proposed variation will allow the pipe to maintain insulation performance for up to 120 minutes.

Based on the above, it is expected that the proposed construction will achieve an FRL of -/120/120 when installed in a minimum 116mm thick plasterboard lined stud walls as shown in Tables B4 and B5 below when tested in accordance with AS 1530.4 – 2014 and assessed in accordance with AS 4072.1 - 2005.

**Copper and steel Pipes up to 150mm in diameter penetrating masonry and concrete walls**

The proposed variation comprises a change in the penetration element from plasterboard lined wall equivalent or thicker masonry and concrete wall.

The change from a hollow plasterboard wall to a thicker masonry or concrete wall will result in a heat sink effect whereby the masonry or concrete wall will absorb furnace heat that would have otherwise heated up the metal pipes, thus allowing less heat to travel to the unexposed side. Subsequently, the integrity and insulation performance of the specimens are expected to improve.

Confidence in the ability of a concrete wall to perform for the required FRL is offered by reference to AS 3600-2018 clause 5.5, where the required wall thicknesses by that standard are the same as those proposed for the given FRL.

Confidence in the ability of the masonry wall to perform for the required FRL is offered by reference to AS 3700-2018 clause 6.5, where the required wall thicknesses by that standard are the same as those proposed for the given FRL.

Based on the above, it is expected that the proposed construction will achieve an FRL of -/60/60, -/90/90 and -/120/120 when installed in minimum 90mm thick, 110mm thick and 130mm thick masonry/concrete walls when tested in accordance with AS 1530.4 – 2014 and assessed in accordance with AS 4072.1 -2005.

**Copper and steel Pipes up to 150mm in diameter penetrating AAC and Speedpanel wall systems**

The proposed construction comprises copper and steel pipes up to 150mm in diameter penetrating various panel wall systems with various lengths of Twrap and fillet sizes.

With reference Table, B3b shows the test results of various metal pipes penetrating various types of panel barriers.

**Table B3b: Metal pipes in panel walls with Twrap**

Test specimen	Support construction	Depth of Fyreflex (mm)	Annular gap (mm)	Fillet on Unexposed side (H x W) (mm)	Twrap (mm)	Protected Pipe	Integrity (min.)	Insulation (min.)
FP 6372 (2b)	75mm AAC	75	6	15 x 15	300mm on each side	50mm x 1.22mm copper pipe	125NF	117(pipe)
FP 11935-001(1)	60mm Blue Maxilite	60	10	50 x 50	420mm fireside 600mm non-fireside (75mm overlap)	100mm x 1.7mm copper pipe	180NF	88 (Maxilite) 136 (wrap)

Test specimen	Support construction	Depth of Fyreflex (mm)	Annular gap (mm)	Fillet on Unexposed side (H x W) (mm)	Twrap (mm)	Protected Pipe	Integrity (min.)	Insulation (min.)
FP 11935-001(2)	60mm Blue Maxilite	60	10	50 x 50	2 layers of 420mm wrap on fireside 1100mm non-fireside with additional 300mm 2 <sup>nd</sup> layer of wrap	150mm x 1.8mm copper pipe	180NF	104 (Maxilite) 137 (wrap)
FSP 1753 (4)	75mm AAC	20 each side	8.5	15 x 15	300mm on each side	48mm x 3.5mm steel pipe	121NF	121NF
FRT 190298 R1.1 (A)	78mm Speedpanel	78	3.5	30 x 30	300mm fireside 450mm non-fireside	100mm x 3.1mm steel pipe	121NF	113 (Speed-panel)
FRT 180392.1 (H)	116mm Plasterboard lined stud wall	26+26	10	15 x 15	800mm on each side	152.4 x 2.03mm copper pipe	130NF	51 (pipe) 110 (wrap) 118 (wall)
FRT 200160.2 (E)	60mm Pronto Panel	60	16	40 x 40	NA	48mm x 3.2mm steel	121	71
FRT 200397 R1.2 (10)	2 layers of 60mm thick Fyrebatt	120	5	50 x 50	Twrap 300mm exposed side, 450mm unexposed face	150 x 4.9mm wall thickness steel pipe metal capping	240 NF	213 (Batt) 231 (Wrap) 119 (pipe)

#### **Insulation of up to NB 40 Steel pipes in 90 minute AAC wall system**

The proposed construction comprises 50mm diameter copper and steel pipes installed in an AAC wall system with an FRL of -/90/90, protected with a 40mm fillet of sealant on each side.

With reference to the results of test FRT 200160.2 Specimen B, this specimen demonstrated that a 60mm Pronto Panel wall system penetrated by NB 40 steel pipes and protected by a 40mm fillet on each side can maintain integrity for more than 90 minutes and insulation for 71 minutes.

The proposed 75mm barrier has less thermal mass than the tested 60mm Pronto Panel, which would result in a slightly hotter pipe on the unexposed side.

However, the 75mm Hebel wall is 15mm thicker than the 60mm Pronto wall, resulting in a longer conduction path for heat to travel in the pipe. This would therefore allow the pipe on the unexposed side to be slightly cooler.

On balance, and given the 11 minutes in insulation performance, it is expected that the proposed construction will be able to maintain integrity and insulation for up to 90 minutes and 60 minutes respectively when tested in accordance with AS 1530.4 – 2014 and assessed in accordance with AS 4072.1 -2005.



### ***Up to 50mm diameter copper and steel pipes in 90 minute AAC wall system***

The proposed construction comprises 50mm diameter copper and steel pipes installed in an AAC wall system with an FRL of -/90/90, protected with 300mm Twrap on each side.

With reference to FP 6372 specimen 2b and FSP 1753 specimen 4, these specimens demonstrated that a 75mm AAC panel wall system penetrated by copper and steel pipes up to 50mm diameter and protected by 300mm Twrap can maintain integrity and insulation for more than 90 minutes.

Provided that the proposed single mesh reinforced AAC panel wall system has a tested or assessed FRL of -/90/90, it is expected that when it is penetrated by copper and steel pipes up to 50mm diameter and protected by 300mm Twrap, it will also maintain integrity and insulation for up to 90 minutes.

Steel has a lower thermal conductivity than copper and when pipes are larger and thicker they will conduct more heat than a smaller and thinner pipe. Therefore, the result for FSP 1753 specimen 4, may be applied to copper and ferrous metal pipes having outside diameters not greater than the tested diameter, and copper pipes with a wall thickness not more than the tested thickness in the referenced test.

For steel pipes, the slight increase in wall thickness can be tolerated as it will balance out the less conductive nature of the steel pipe. On balance, it is expected that the proposed steel pipe will perform similar or better than the tested pipe in the referenced test.

Based on the above, it is expected that the proposed construction will be able to maintain integrity and insulation for up to 90 minutes when tested in accordance with AS 1530.4 – 2014 and assessed in accordance with AS 4072.1 -2005.

### ***Up to 50mm diameter copper metal pipes in 120 minute AAC wall system and Speedpanel wall system***

The proposed construction comprises 50mm diameter copper pipes installed in an AAC wall system with an FRL of -/120/120, protected with 300 or 350mm Twrap on each side, or in a Speedpanel wall system with an FRL of -/120/120, protected with 300mm Twrap on each side.

With reference to FP 6372 specimen 2b, this specimen demonstrated that a 75mm AAC panel wall system penetrated by copper up to 50mm diameter and protected by 300mm Twrap, was able to maintain integrity for more than 120 minutes, although the temperature of the pipe measured a 182°C temperature at 120 minutes.

The proposed increase in Twrap length by 50mm on each side of the wall will increase the conduction path between the furnace and the unexposed side of the pipe, allowing the pipe to maintain insulation for at least 120 minutes.

Alternatively, the proposed additional layer of 60mm thick Maxilite collar around the penetration on one side of the wall will also increase the conduction path between the furnace and the unexposed side of the pipe, allowing the pipe to maintain insulation for at least 120 minutes.

Provided that the proposed double caged reinforced AAC panel wall system has a tested or assessed FRL of -/120/120, it is expected that when it is penetrated by copper pipes up to 50mm diameter and protected by either 300mm Twrap with the extra layer of Maxilite collar at the panel penetration or 350mm Twrap, it will also maintain integrity and insulation for up to 120 minutes.

The proposed Speedpanel wall barrier is thicker than the tested 75mm AAC wall system. Provided that the proposed Speedpanel wall system has a tested or assessed FRL of -/120/120, it is expected that when it is penetrated by copper pipes up to 50mm diameter and protected by 300mm Twrap with the extra layer of Maxilite collar at the panel penetration, it will also maintain integrity and insulation for up to 120 minutes.

Based on the above, it is expected that the proposed construction will be able to maintain integrity and insulation for up to 120 minutes when tested in accordance with AS 1530.4 – 2014 and assessed in accordance with AS 4072.1 -2005.



### ***Up to 50mm diameter steel pipes in 120 minute AAC wall system and Speedpanel wall system***

The proposed construction comprises 50mm diameter steel pipes installed in an AAC wall system and a Speedpanel wall system with an FRL of -/120/120, protected with 300mm Twrap on each side.

With reference to FSP 1753 specimen 4, this specimen demonstrated that a 75mm AAC panel wall system penetrated by steel pipe up to 50mm diameter and protected by 300mm Twrap is able to maintain integrity and insulation for more than 120 minutes.

Provided that the proposed double caged reinforced AAC panel wall system has a tested or assessed FRL of -/120/120, it is expected that when it is penetrated by steel pipes up to 50mm diameter and protected by either 300mm Twrap, it will also maintain integrity and insulation for up to 120 minutes.

The proposed Speedpanel wall barrier is thicker than the tested 75mm AAC wall system. Provided that the proposed Speedpanel wall system has a tested or assessed FRL of -/120/120, it is expected that when it is penetrated by steel pipes up to 50mm diameter and protected by 300mm Twrap, it will also maintain integrity and insulation for up to 120 minutes.

Based on the above, it is expected that the proposed construction will be able to maintain integrity and insulation for up to 120 minutes when tested in accordance with AS 1530.4 – 2014 and assessed in accordance with AS 4072.1 -2005.

### ***Up to 100mm diameter copper pipes in 90 minute and 120 minute AAC wall systems and 120 minute Speedpanel wall system***

The proposed construction comprises 100mm diameter copper and steel pipes installed in an AAC wall system with an FRL of -/90/90 and -/120/120 as well as a Speedpanel wall system with an FRL of -/120/120, protected with 600mm Twrap on each side.

With reference to FP 11935-001 specimen 1, this specimen demonstrated that a minimum 60mm thick panel wall system penetrated by a maximum 100mm diameter copper by 600mm Twrap is able to maintain integrity at the seal for more than 121 minutes as well as maintaining insulation on the pipe for at least 121 minutes. The 60mm Maxilite barrier failed insulation at 88 minutes.

The proposed 75mm single mesh AAC wall and the 75mm double caged AAC wall barrier with an additional 60mm thick Maxilite collar are both thicker than the tested 60mm Maxilite barrier in FP 11935-001 specimen 1, which will result in a deep sealant depth in the annular gap. This will allow the seal to perform better. A thicker barrier will also result in an increase in the conduction path of the metal pipe from the furnace to the unexposed side, resulting in better insulation performance of the metal pipe on the unexposed side.

Provided that the proposed single mesh reinforced AAC panel wall system has a tested or assessed FRL of -/90/90, it is expected that when it is penetrated by copper pipes up to 100mm diameter and protected by 600mm Twrap, it will also maintain integrity and insulation for up to 90 minutes.

Provided that the proposed double caged reinforced AAC panel wall system has a tested or assessed FRL of -/120/120, it is expected that when it is penetrated by copper pipes up to 100mm diameter and protected by 600mm Twrap with the extra layer of Maxilite collar at the panel penetration, it will also maintain integrity and insulation for up to 120 minutes.

The proposed Speedpanel wall barrier is thicker than the tested 60mm Maxilite wall barrier. Provided that the proposed Speedpanel wall system has a tested or assessed FRL of -/120/120, it is expected that when it is penetrated by copper pipes up to 100mm diameter and protected by 600mm Twrap with the extra layer of Maxilite collar at the panel penetration, it will also maintain integrity and insulation for up to 120 minutes.

Based on the above, it is expected that the proposed construction will be able to maintain integrity and insulation for up to 90 and 120 minutes when tested in accordance with AS 1530.4 – 2014 and assessed in accordance with AS 4072.1 -2005.

### ***Up to 100mm diameter steel pipes in 90 minute and 120 minute AAC wall systems and 120 minute Speedpanel wall system***

The proposed construction comprises 100mm diameter steel pipes installed in an AAC wall system with an FRL of -/90/90 and -/120/120 as well as a Speedpanel wall system with an FRL of -/120/120, protected with 450mm Twrap on each side.

With reference to FRT 190298 R1.1 specimen A, this specimen demonstrated that a minimum 78mm thick Speedpanel wall system penetrated by a maximum of 100mm diameter steel pipes and protected by 450mm Twrap can maintain integrity at the seal for more than 121 minutes and insulation for more than 121 minutes.

It is expected the proposed additional 60mm Maxilite collar will not detrimentally affect its integrity and insulation performance for up to 120 minutes.

The proposed 75mm single mesh AAC wall system is slightly thinner than the 78mm Speedpanel wall tested in FRT 190298 R1.1 specimen A. Given the 30 minutes margin in integrity, it is expected that the sealant in the annular gap will be able to maintain integrity for at least 90 minutes. Given the 30 minutes margin in insulation, it is also expected that the steel pipe will be able to maintain insulation for at least 90 minutes.

Provided that the proposed single mesh reinforced AAC panel wall system has a tested or assessed FRL of -/90/90, it is expected that when it is penetrated by a maximum of 100mm diameter steel pipes and protected by 450mm Twrap, it will be able to maintain insulation for at least 90 minutes.

The proposed 75mm double caged system with the additional 60mm Maxilite collar is thicker than the tested 78mm thick Speedpanel wall in FRT 190298 R1.1 specimen A, which will result in a deep sealant depth in the annular gap. This will allow the seal to perform better. A thicker barrier will also result in an increase in the conduction path of the metal pipe from the furnace to the unexposed side, resulting in better insulation performance of the metal pipe on the unexposed side.

Provided that the proposed double caged reinforced AAC panel wall system has a tested or assessed FRL of -/120/120, it is expected that when it is penetrated by a maximum of 100mm diameter steel pipes and protected by 450mm Twrap with the extra layer of Maxilite collar at the panel penetration, it will be able to maintain insulation for more than 120 minutes.

Based on the above, it is expected that the proposed construction will be able to maintain integrity and insulation for up to 90 minutes and 120 minutes when tested in accordance with AS 1530.4 – 2014 and assessed in accordance with AS 4072.1 -2005.

### ***Up to 150mm diameter copper and steel pipes in 90 minute AAC wall system***

The proposed construction comprises copper pipes up to DN150 installed in an AAC wall system with an FRL of -/90/90 and protected with 1050mm Twrap on each side.

With reference to FRT 180392.1 specimen H, the 150mm copper pipe with 800mm Twrap on each side of the 116mm plasterboard wall measured 217°K temperature rise on the pipe at 90 minutes and 228°C at 120 minutes. The wrap failed insulation at 110 minutes.

The proposed wall thickness is 41mm less than the tested wall thickness, which will result in a higher temperature reading on the pipe on the unexposed side due to a decrease in the conduction path.

However, the furnace severity experienced by the pipe at 90 minutes is much less than that at 120 minutes. With the proposed increase in wrap length, the conduction path will also increase between the furnace side and the unexposed side.

On balance, it is expected that the temperature rise measured on the pipe on the unexposed side will be less than that tested.

Steel has a lower thermal conductivity than copper and when pipes are larger and thicker they will conduct more heat than a smaller and thinner pipe. Therefore, the result for FRT 180392.1 specimen

H may be applied to copper and ferrous metal pipes having outside diameters not greater than the tested diameter, and copper pipes with a wall thickness not more than the tested thickness in the referenced test.

For steel pipes, the slight increase in wall thickness can be tolerated as it will balance out the less conductive nature of the steel pipe. On balance, it is expected that the proposed steel pipe will perform similar or better than the tested pipe in the referenced test.

Provided that the proposed single mesh reinforced AAC panel wall system has a tested or assessed FRL of -/90/90, it is expected that when it is penetrated by copper and steel pipes up to 150mm diameter and protected by 1050mm Twrap, it will also maintain integrity and insulation for up to 90 minutes.

Based on the above, it is expected that the proposed construction will achieve an FRL of -/90/90 when installed in minimum 75mm thick single-caged AAC walls when tested in accordance with AS 1530.4 – 2014 and assessed in accordance with AS 4072.1 -2005.

#### ***Up to 150mm diameter copper pipes in 120 minute AAC wall system and Speedpanel wall system***

The proposed construction comprises copper pipes up to DN150 installed in an AAC wall and Speedpanel wall systems with an FRL of -/120/120 protected on each side with 1100mm Twrap and with an additional layer of 300mm Twrap on each side.

With reference to FP 11935-001 Specimen 2, the 150mm copper pipe penetrated a 60mm thick Maxilite barrier and was protected with 2 layers of 420mm wrap on the furnace side and 1100mm with an additional 300mm of Twrap on the unexposed side. The specimen measured 144°K temperature rise on the pipe at 120 minutes. The Maxilite barrier failed insulation at 104 minutes. The specimen did not fail integrity for at least 180 minutes.

The proposed additional 60mm Maxilite collar will also provide the wall barrier with an additional 60 minutes of insulation performance, allowing the wall to maintain insulation for at least 120 minutes.

Provided that the proposed double caged reinforced AAC panel wall and Speedpanel wall system are tested or assessed FRL of -/120/120, it is expected that when these wall types are penetrated by copper pipes up to 150mm diameter and protected by 1100mm Twrap plus an additional 300mm of Twrap, as well as the extra layer of Maxilite collar at the panel penetration, the penetration will be able to maintain integrity and insulation for up to 120 minutes.

Based on the above, it is expected that the proposed construction will achieve an FRL of -/120/120 when tested in accordance with AS 1530.4 – 2014 and assessed in accordance with AS 4072.1 -2005.

#### ***Up to 150mm diameter steel pipes in 120 minute AAC wall system and Speedpanel wall system***

The proposed construction comprises steel pipes up to NB150 installed in an AAC wall and Speedpanel wall systems with an FRL of -/120/120, protected on each side with 900mm Twrap and with an additional layer of 300mm Twrap on each side.

With reference to FRT 190292.5 Specimen G, a 150mm steel pipe with 600mm wrap above the 175mm thick concrete slab measured a 122°K temperature rise on the pipe at 120 minutes.

It is considered reasonable and conservative to apply the insulation performance pipe tested on the floor to a wall, provided allowance is made for the thickness of the separating element.

The proposed barriers, when including the additional 60mm Maxilite collar, has a total thickness of 135 and 138mm for the AAC and Speedpanel wall system respectively. Both proposed barriers are thinner and contain less thermal mass than the tested 175mm concrete slab, which will result in a higher pipe temperature on the unexposed end.

However, the proposed 300mm increase in Twrap length on each side of the wall will greatly increase the conduction path between the furnace and the unexposed side of the pipe, reducing the temperature measured on the pipe. The tested steel pipe also has a 58°C margin of insulation performance at 120 minutes.

It is expected that the positive effect of Twrap increase, as well as the margin in pipe insulation, will balance out the negative effect of the reduction in barrier thickness.

The proposed fillet size is half the size of that tested in FRT 190292.5 Specimen G. However, the proposed sealant depth is 10mm greater than that tested in FRT 190292.5 Specimen G. Also, the proposed construction also comprises fillets of sealant on both sides of the barrier. Both of these factors will act to balance out the effect of a reduction in fillet size.

With reference to FP 11935-001 Specimen 2, it is demonstrated that when a 150mm copper pipe penetrated a thick barrier, it requires an additional layer of Twrap so as to allow the Twrap to also maintain insulation for up to 120 minutes. Therefore, to be conservative, it is required that 150mm diameter steel pipes also require an additional layer of Twrap.

Provided that the proposed double caged reinforced AAC panel wall and Speedpanel wall system have a tested or assessed FRL of -/120/120, it is expected that when these wall types are penetrated by steel pipes up to 150mm diameter and protected by 900mm Twrap plus an additional 300mm of Twrap, as well as the extra layer of Maxilite collar at the panel penetration, the penetration will be able to maintain integrity and insulation for up to 120 minutes.

Based on the above, it is expected that the proposed construction will achieve an FRL of -/120/120 when tested in accordance with AS 1530.4 – 2014 and assessed in accordance with AS 4072.1 -2005

#### ***Up to 150mm diameter steel pipes in Speedpanel wall system – 90 minute insulation performance***

The proposed construction is similar to the proposed construction discussed in the section above, except it has no additional layer of 300mm Twrap on each side of the double caged AAC wall with an FRL of -/120/120.

With reference to FRT 180392.1 specimen H, the 150mm copper pipe with 800mm Twrap on each side of the wall measured 217°K temperature rise on the pipe at 90 minutes. The wrap failed insulation at 110 minutes.

Steel has a lower thermal conductivity than copper, therefore it is expected that the one layer of Twrap on the proposed 150mm steel pipe will perform similar or better than that in FRT 180392.1 specimen H, allowing the proposed construction to maintain insulation for at least 90 minutes.

Based on the above, it is expected that the proposed construction will achieve an FRL of -/120/90 when tested in accordance with AS 1530.4 – 2014 and assessed in accordance with AS 4072.1 -2005.

#### ***Up to 150mm diameter Copper pipes in Speedpanel wall system – 90 minute insulation performance***

The proposed construction comprises a 150mm diameter copper pipe in a Speedpanel wall system with an FRL of -/120/120, protected on each side with a 900mm length of Twrap.

With reference to FRT 180392.1 specimen H, the 150mm copper pipe with 800mm Twrap on each side of the wall measured 217°K temperature rise on the pipe at 90 minutes. The wrap failed insulation at 110 minutes.

The proposed barriers, when including the additional 60mm Maxilite collar, has a total thickness of 138mm, which is thicker than the tested 116mm plasterboard wall. Combined with the proposed increase in wrap length by 100mm, the conduction path will also increase between the furnace side and the unexposed side, which will reduce the temperature of the pipe on the unexposed side.

Both the Speedpanel wall and the 60mm Maxilite collar will have greater heat capacity than the hollow plasterboard wall. This will also act to draw heat away from the pipe, allowing the pipe temperature to decrease on the unexposed side.

Overall, it is expected that the temperature rise measured on the pipe on the unexposed side will be less than that tested such as to allow the pipe to maintain insulation for up to 90 minutes.

Based on the above, it is expected that the proposed construction will achieve an FRL of -/120/90 when tested in accordance with AS 1530.4 – 2014 and assessed in accordance with AS 4072.1 -2005

### ***Sealant fillet size***

The proposed fillet size is much smaller than some of the tested specimens in Table B3b. However, it is observed that when the 150mm copper pipe was tested in plasterboard lined stud wall in FRT 180392.1 specimen H, it only had a 15mm x 15mm fillet on each side of the wall.

The plasterboard barrier tested in FRT 180392.1 specimen H is considered to be more onerous than the solid panel barriers proposed due to the shallower sealant depth at the aperture allowed in a plasterboard lined wall compared to a solid panel wall.

Therefore, it is expected that when the 15mm x 15mm fillet is also applied to a 150mm copper pipe in the proposed solid panel walls, the integrity of the aperture will not be detrimentally affected for up to 120 minutes.

With reference to the specimens in Table B3b, no flaming integrity failure has been observed in relation to the failure of sealant for at least 120 minutes. Therefore, it is expected that the proposed slight increase in the annular gap to 10mm will not detrimentally affect the integrity or insulation performance of 150mm diameter copper and steel pipes for up to 120 minutes.

### ***Confirmation of service spacing***

AS 4072.1 -2005 clause 4.9.3 states that “the minimum distance between penetrations in a modular system shall be not less than 40 mm unless otherwise tested in specimen form.” It is noted also in clause 1.4.10 which defines a “penetration” as “An aperture through a fire-separating element for the passage of a service or services”

Based on the above, it is considered that AS 4072.1 -2005 Amdt. 1 clause 4.9.3 is applicable to the specimens considered in this assessment. The minimum aperture to aperture spacing of the proposed specimens is 40mm.

### ***Copper and steel Pipes up to 150mm in diameter penetrating masonry and concrete walls for 240-minute applications***

The proposed construction comprises 150mm diameter copper with a wall thickness of 2.03mm or 150mm diameter steel pipe installed in a min.180mm thick masonry/concrete wall system with an FRL of -/240/240, protected on each side with 50mm x 50mm sealant and 1500mm length of Twrap with an additional layer of 300mm of Twrap.

With reference to FRT200397 R1.2 Specimen 11, the 150mm x 2.03mm copper pipe penetrated a 120mm thick batt system and was protected with 300mm Twrap on the furnace side and 1100mm with an additional 300mm of Twrap on the unexposed side. The pipe was able to maintain integrity and insulation for up to 240 minutes.

With the proposed construction the increase in wall depth and increase in wrap length will result in an increase in the conduction path between the furnace side and the unexposed side pipe. It is expected that the temperature rise measured on the pipe on the unexposed side will be less than that tested.

Steel has a lower thermal conductivity than copper and when both pipes are larger and thicker, they will conduct more heat than a smaller and thinner pipe. Therefore, the result for FRT200397 R1.2 Specimen 11, may be applied to copper and ferrous metal pipes having outside diameters not greater than the tested diameter, and copper pipes with a wall thickness not more than the tested thickness in the referenced test.

For steel pipes, the slight increase in wall thickness can be tolerated as it will balance out the less conductive nature of the steel pipe. On balance, it is expected that the proposed steel pipe will perform similar or better than the tested pipe in the referenced test.

Based on the above, it is expected that the proposed construction will achieve an FRL of -/240/240 when tested in accordance with AS 1530.4 – 2014 and assessed in accordance with AS 4072.1 -2005.

**Stainless steel pipes penetrating various walls**

The proposed construction comprises up to 54mm and up to 170mm maximum diameter stainless steel pipes penetrating the various wall types discussed above, protected with various sizes of sealant and various lengths of Twrap as shown in Table B3c.

**Table B3c: Proposed Stainless steel pipes in walls with Twrap**

Stainless-steel pipe	Twrap or Fyrewrap length on each side of the wall (mm)	Support construction thickness (mm)	The gap around the pipe (mm)	Fyreflex sealant depth (mm)	Fyreflex sealant fillet size (h x w) (mm)
Up to 54mm and a minimum 1.5mm wall thickness	300mm	1 x 13mm Single-layer plasterboard walls (min. 90mm thick) Tested or assessed FRL of -/60/60.	≤10mm	Full depth of plasterboard linings	50 x 50
		1 x 16mm single-layer plasterboard walls (min. 96mm thick) Tested or assessed FRL of -/90/90.			
Up to 170mm and a minimum 1.5mm wall thickness	1100mm with an additional layer of 300mm wrap	2 x 13 or 16mm plasterboard walls (min. 116mm thick) Tested or assessed FRL of - /120/120			
Up to 54mm and a minimum 1.5mm wall thickness	300mm	Min. 75mm single mesh reinforced AAC panel walls tested or assessed FRL of - /90/90		Fyreflex to the full depth of the AAC panel	30 x 30
Up to 170mm and a minimum 1.5mm wall thickness	1050mm				
Up to 54mm and a minimum 1.5mm wall thickness	300mm	Min. 78mm Speedpanel wall tested or assessed FRL of -/120/120		Fyreflex to the full depth of Speedpanel	30 x 30
Up to 170mm and a minimum 1.5mm wall thickness	1100mm with an additional layer of 300mm wrap				
Up to 54mm and a minimum	450	Min. 120mm concrete wall in accordance with AS 3600 -2018	≤10mm	30mm from each side	30 x 30



Stainless-steel pipe	Twrap or Fyrewrap length on each side of the wall (mm)	Support construction thickness (mm)	The gap around the pipe (mm)	Fyreflex sealant depth (mm)	Fyreflex sealant fillet size (h x w) (mm)
1.5mm wall thickness	300	Min. 150mm and 170mm concrete wall in accordance with AS 3600 -2018			
Up to 170mm and a minimum 1.5mm wall thickness	2 x 800	Min. 120mm concrete wall in accordance with AS 3600 -2018			
		Min. 150mm and 175mm concrete wall in accordance with AS 3600 -2018			
Up to 54mm and a minimum 1.5mm wall thickness	450	Min. 130mm concrete wall in accordance with AS 3700 -2018			
	300	Min. 160mm and 180mm concrete wall in accordance with AS 3700 -2018			
Up to 170mm and a minimum 1.5mm wall thickness	2 x 800	Min. 130mm concrete wall in accordance with AS 3700 -2018			
		Min. 160mm and 180mm concrete wall in accordance with AS 3700 -2018			

#### *Stainless steel pipes in concrete or masonry walls*

The proposed construction for stainless steel pipes in concrete or masonry walls is similar to that for stainless steel pipes in slabs except for the wrap and fillet of sealant are applied on both sides of the wall while the depth of sealant is distributed evenly on each side of the wall so that the total sealant depth remains at 60mm as tested.

It is understood the stainless-steel pipe will remain rigid for the duration of the test and is not prone to collapse, it is reasonable to apply their result when tested in a slab to when installed in a similarly rigid wall where the additional wrap on the fireside will slightly improve the performance of the pipe compared the tested configuration wrapped one side.

Based on the above, it is expected that the proposed construction will achieve integrity and insulation of up to 120, 180 and 240 minutes based on design when tested in accordance with AS 1530.4 – 2014 and assessed in accordance with AS 4072.1 -2005.

#### *Stainless steel pipes in Hebel, Speedpanel and plasterboard walls*

The proposed construction comprises stainless steel pipes tested in FSP 2317 specimens 5 and 6 to be installed in lightweight wall systems as discussed above.

With reference to the 54mm, stainless steel pipe tested in FSP 2317 specimen 5 to the 50mm copper pipe tested in FRT 180391 specimen A, when the difference in slab thickness and therefore the effect of thermal mass is accounted for before the copper pipe melted, the 54mm stainless steel pipe wrapped with 300mm Twrap performed similar or slightly better than the 50mm copper pipe with the same wrap length.

With reference to the 170mm stainless steel pipe tested in FSP 2317 specimen 6 to the 150mm copper pipe tested in FRT 180391 specimen B, a similar comparison can be made as above, and it is also observed that the 170mm stainless steel pipe wrapped with 800mm Twrap performed similar or slightly better than the 150mm copper pipe with the same wrap length.



Therefore, it is reasonable to apply the result and variations made to DN50mm and DN150mm copper pipes in various lightweight wall types as discussed above to 54mm and 170mm stainless steel pipes in these walls respectively.

The proposed constructions in Hebel walls are also protected with a slightly larger fillet than that for copper pipe, which will act to improve the performance of the seal around the pipe.

Based on the above, it is expected that the proposed construction will achieve integrity and insulation of up to 120, 180 and 240 minutes based on design when tested in accordance with AS 1530.4 – 2014 and assessed in accordance with AS 4072.1 -2005.

## B.4 Variation to cable in floors – discontinuous cable tray without wraps

The proposed construction shall be for penetrations as tested in NI 1089, NI 2689 and EWFA 51894700.1 when subject to the following variations;

- Variation of slab thickness to 120mm where possible
- Variation to include cable tray for 1m on either side of the concrete slab no closer than 100mm from the slab on each side.
- Sealant depth and fillet size shall vary.
- The separation of the specimens shall be at least 40mm refer to Figure 5a

### **Cables in NI 1089**

The proposed construction shall be cables tested in NI 1089 specimen B with an increase of slab support construction thickness to a minimum of 175mm thick.

With reference to NI 1089 specimen B as summarized in Table A2, cables extended 2000mm away from the furnace, which is much longer than the 500mm extension length allowed in AS 1530.4 -2014. The proposed construction would only have a 500mm extension and thus would be getting hotter at a faster rate than that tested in NI 1089 as there is now less conductive material to carry heat away on the unexposed side. Therefore, it is expected it will reach insulation failure sooner than 110 minutes.

However, the increase in slab thickness will also act to cool the cables down and improve the performance of the seal around the cables, thus allowing the penetration seal to maintain integrity for longer.

Confidence in the ability of the concrete slab to perform for the required FRL is offered by reference to AS 3600-2018 clause 5.5, where the required slab thicknesses by that standard are the same as those proposed for the given FRL.

On balance, it is expected that the proposed construction will be able to maintain integrity for up to 240 minutes and insulation for 110 minutes when tested in accordance with AS 1530.4-2014 and assessed in accordance with AS 4072.1 -2005 Amdt. 1.

### **Cables in EWFA 51894700.1**

The proposed construction shall be cables tested in EWFA 51894700.1 specimen 4 with the inclusion of a minimum 175mm concrete slab as a support construction.

It is expected that the concrete slab support construction with its relatively higher heat capacity will act to absorb more heat from the cables than the 60mm Maxilite as tested in EWFA 51894700.1 and thus allow the penetration seal to maintain integrity for longer.

Confidence in the ability of the concrete slab to perform for the required FRL is offered by reference to AS 3600-2018 clause 5.5, where the required slab thicknesses by that standard are the same as those proposed for the given FRL.

On balance, it is expected that the proposed construction will be able to maintain integrity for up to 240 minutes and insulation for 60 minutes when tested in accordance with AS 1530.4-2014 and assessed in accordance with AS 4072.1 -2005 Amdt. 1.

#### **Cables and cable trays in NI 2689**

The proposed construction shall be cables tested in NI 2689 with the inclusion of a minimum 120mm concrete slab as a support construction.

With reference to NI 2689 specimens B, D, F, G, J and L as summarized in Table A2, cables extended 2000mm away from the furnace, which is much longer than the 500mm extension length allowed in AS 1530.4 -2014. The proposed construction would only have a 500mm extension and thus would be getting hotter at a faster rate than that tested in NI 2689 as there are now fewer conductive materials to carry heat away on the unexposed side. Therefore, it is expected it will reach sealant and may degrade sooner than that tested in NI 2689.

However, it is expected that the proposed concrete slab support construction with its relatively higher heat capacity will act to absorb more heat from the cables than the 75mm E Core panel as tested in NI 2689 and thus allow the penetration seal to maintain integrity for longer.

It is also proposed to increase the cable trays as tested in NI 2689 specimens L and J to a maximum width of 1000mm. Since the cable tray does not penetrate the support construction and is kept at the tested distance of 100mm away from the slab and 50mm away from the sealant fillet, it is expected that it will not interact with the penetration seal and thus will not detrimentally affect the integrity performance of the penetrations.

Confidence in the ability of the concrete slab to perform for the required FRL is offered by reference to AS 3600-2018 clause 5.5, where the required slab thicknesses by that standard are the same as those proposed for the given FRL.

On balance, it is expected that the proposed construction will be able to maintain integrity for up to 120 minutes when tested in accordance with AS 1530.4-2014 and assessed in accordance with AS 4072.1 -2005 Amdt. 1.

#### **Confirmation of service spacing**

AS 4072.1 -2005 clause 4.9.3 states that “the minimum distance between penetrations in a modular system shall be not less than 40 mm unless otherwise tested in specimen form.” It is noted also in clause 1.4.10 which defines a “penetration” as “An aperture through a fire-separating element for the passage of a service or services”

Based on the above, it is considered that AS 4072.1 -2005 Amdt. 1 clause 4.9.3 is applicable to the specimens considered in this assessment. The minimum aperture to aperture spacing of the proposed specimens is 40mm.

## **B.5 Variation to cable in floors – continuous cable trays with wrap**

The proposed construction shall be for penetrations as tested in FSP 2052, FRT 190292.5 and FRT 180931.1 when subject to the following variations;

- Inclusion of min. 120mm thick slab thickness penetrated by specimen as tested in FSP 2052 specimens 3, 4 and 5
- Inclusion of 120mm and 175mm thick slab penetrated by specimen as tested in FRT 190292.5 specimen E1.
- Inclusion of 175mm thick slab penetrated by specimen as tested in FRT 190292.5 specimen E1, with 630mm<sup>2</sup> single core cable removed, and protected two layers of 450mm length of Twrap on specimen instead of tested one layer

- Inclusion of 120mm thick slab penetrated by specimen as tested in FRT 180931.1 specimen C, with 630 mm<sup>2</sup> single core cable removed.
- Wrap to be installed with overlap as per Figures 13-14
- The separation of the specimens shall be at least 40mm refer to Figure 5b

The proposed variation to specimens 3, 4 and 5 as tested in FSP 2052 comprises a reduction of slab thickness to 120mm.

With reference to FSP 2052, the various cable bundle specimens penetrated a 150mm thick concrete slab. None of the specimens had integrity nor insulation failure due to the slab near their penetration.

The proposed variation comprises reducing the slab thickness from the tested 150mm to 120mm thick, which is a 20% reduction in slab mass.

The depth of sealant remains the same depth in the proposed construction. The reduction in slab mass will reduce the heat sink effect provided by the slab, and so increase the temperature of the sealant fillet on the unexposed side.

The maximum temperature recorded on the tested specimen fillets at 120 minutes was 119°C, which is a 42% margin till insulation failure. It is expected that this margin is more than sufficient to account for the 20% reduction in slab mass and the consequent temperature rise of the sealant.

Confidence in the ability of the concrete slab to perform for the required insulation performance of 120 minutes is offered by reference to AS 3600-2018 clause 5.5, where the required thickness for a slab to maintain insulation for 120 minutes is 120mm.

Based on the above, it is expected that the proposed construction will not detrimentally affect the fire resistance performance of the specimens in FSP 2052 when tested in accordance with AS 1530.4-2014 and assessed in accordance with AS 4072.1 -2005 Amdt. 1.

#### ***120 and 180 minute insulation systems***

The proposed variation to FRT 190292.5 specimen E1 comprises the inclusion of 120mm and 175mm thick slab as support construction.

With reference to FRT 190292.5 specimen E1, a set of Appendix D1 cables on a 315mm wide x 50mm deep cable tray penetrated a 60mm thick horizontally orientated white Maxilite board and was protected with 50mm x 50mm fillets on the exposed side of the board and then wrapped in 450mm length of Twrap. Loose mineral wool was used to fill the gap between wrap and service. The specimen did not fail integrity for 241 minutes and failed insulation at 154 minutes on the Maxilite board at the penetration. The 630mm<sup>2</sup> single core cable was able to maintain insulation for 184 minutes while the remaining cables were all able to maintain insulation for 240 minutes.

It is expected that the proposed concrete slab support construction with its relatively higher heat capacity will act to absorb more heat from the cables than the 60mm Maxilite as tested in FRT 190292.5 and thus allow the penetration seal to maintain integrity for longer.

Confidence in the ability of the concrete slab to perform for the required FRL is offered by reference to AS 3600-2018 clause 5.5, where the required slab thicknesses by that standard are the same as those proposed for the given FRL.

Based on the above, it is expected that the proposed construction will be able to maintain integrity and insulation for up to 120 minutes and 180 minutes for 120mm thick slab and 175mm thick slab respectively when tested in accordance with AS 1530.4-2014 and assessed in accordance with AS 4072.1 -2005 Amdt. 1.

### **240 minute System**

The proposed variation to FRT 190292.5 specimen E1 comprises the inclusion of a 175mm slab as substrate, with 630mm<sup>2</sup> single core cable removed, and protected two layers of 450mm length of Twrap on specimen instead of tested one layer.

With reference to FRT 190292.5 specimen E1, aside from the 630mm<sup>2</sup> single core cable, the remaining cables in specimen E1 were all able to maintain insulation for 240 minutes, with the maximum temperature rise on these cables being 147°C. The Twrap failed insulation at 199 minutes, with the temperature rise on the Twrap at 240 minutes being 355°C.

The proposed removal of the large 630mm<sup>2</sup> single core cable which failed insulation prior to 240 minutes would allow the rest of the specimen to maintain insulation for 240 minutes.

It is shown in specimen E1 that one layer of Twrap was sufficient to maintain the hot specimen insulation performance for 199 minutes. It is expected that the proposed extra layer of Twrap around the cables and cable tray will allow the specimen to maintain insulation for at least another 51 minutes.

It is expected that the proposed concrete slab support construction with its relatively higher heat capacity will act to absorb more heat from the cables than the 60mm Maxilite as tested in FRT 190292.5 and thus allow the penetration seal to maintain integrity for longer.

Based on the above, it is expected that the proposed construction will be able to maintain integrity and insulation for up to 240 minutes for a 175mm thick slab when tested in accordance with AS 1530.4-2014 and assessed in accordance with AS 4072.1 -2005 Amdt. 1.

### **90 minute System**

The proposed variation to FRT 180931.1 specimen C comprises the inclusion of a 120mm thick slab as substrate.

With reference to FRT 180931.1 specimen C, a set of Appendix D1 cables on a 300mm wide x 47mm deep cable tray penetrated a 60mm thick horizontally orientated blue Maxilite board and was protected with 50mm x 50mm fillets on the exposed side of the board and then wrapped in 300mm length of Twrap. Loose mineral wool was used to fill the gap between wrap and service. The specimen fails integrity at 165 minutes and insulation at 62 minutes on the 630mm<sup>2</sup> single core cable.

It is expected that the proposed concrete slab support construction with its relatively higher heat capacity will act to absorb more heat from the cables than the 60mm Maxilite as tested in FRT 190292.5 and thus allow the penetration seal to maintain integrity for longer.

It was observed that the cables experienced core slippage at 60 minutes into the test, thus reducing the heat conducted from the furnace side to the unexposed side, making the wrap temperature and the cable temperature of this specimen unrepresentative.

However, the proposed specimen is similar to that tested in FRT 190292.5 specimen E1 for the 120 minute system discussed above, though the wrap length is reduced by 150mm. Therefore, the wrap temperature for FRT 190292.5 specimen E1 and the cable temperatures for FRT 190292.5 specimen E1 are applicable for this proposed construction for FRT 180931.1 specimen C.

Based on the performance of the Twrap in FRT 190292.5 specimen E1, it is evident that a single layer of Twrap was sufficient to allow the proposed cables and cable tray to maintain insulation for at least 199 minutes. In FRT 190292.5 specimen E1, the temperature rise measured on the 185mm<sup>2</sup> cable at 90 minutes was 94°C.

Taking into consideration the increase in barrier thickness from the tested 60mm Maxilite to the proposed 120mm slab, as well as the decrease in wrap length from the tested 450mm to the proposed 300mm, a thermal gradient calculation was made for the 185mm<sup>2</sup> cable at 90 minutes into the test. It was found that this cable, which is the most severe of the remaining Appendix A D1 cables, was able to not reach 180°K temperature rise at 90 minutes and thus maintain insulation.

Confidence in the ability of the concrete slab to perform for the required FRL is offered by reference to AS 3600-2018 clause 5.5, where the required slab thicknesses by that standard are the same as those proposed for the given FRL.

Based on the above, it is expected that the proposed construction will be able to maintain integrity and insulation for up to 120 minutes for a 120mm thick slab when tested in accordance with AS 1530.4-2014 and assessed in accordance with AS 4072.1 -2005 Amdt. 1.

#### **Confirmation of service spacing**

AS 4072.1 -2005 clause 4.9.3 states that “the minimum distance between penetrations in a modular system shall be not less than 40 mm unless otherwise tested in specimen form.” It is noted also in clause 1.4.10 which defines a “penetration” as “An aperture through a fire-separating element for the passage of a service or services”

Based on the above, it is considered that AS 4072.1 -2005 Amdt. 1 clause 4.9.3 is applicable to the specimens considered in this assessment. The minimum aperture to aperture spacing of the proposed specimens is 40mm.

## **B.6 Variation to cable in walls – continuous cable trays with wrap**

The proposed construction comprises cables tested in FP 11935, FRT 180392.1, FP 6033, FSP 1729A, FSP 1795, and FRT 180323 R4.0 when subject to the following variation:

- The inclusion of min. 75mm thick double caged Hebel wall, min. 78mm thick Speedpanel wall, min. 120mm thick concrete wall and 130mm thick masonry wall designed in accordance with AS 3700 for an FRL of -/180/120 as barriers penetrated by FP 11935 specimen 3.
- The inclusion of cable bundles of up to 10 x CAT 6 or 10 x TPS cables as tested in FRT 180392.1 specimen J.
- The inclusion of cable bundles of up to 8 x 3C+E power cables as tested in FRT 180392.1 specimen C, with a maximum gap between cable and wall to be 20mm.
- The inclusion of cable bundles of up to 3 x 19 mm OD, 3C+E power cables as tested in FP 6033 specimen 8.
- The inclusion of cable bundles of up to 3 x 19 mm OD, 3C+E power cables as tested in FP 6033 specimen 8 penetrating a min. 96mm thick plasterboard lined stud wall lined with a layer of 16mm fire rated plasterboard on each side of the stud.
- The inclusion of cable bundles of up to 3 x 19 mm OD, 3C+E power cables as tested in FP 6033 specimen 8 penetrating a min. 96mm thick plasterboard lined stud wall lined with a layer of 16mm fire rated plasterboard on each side of the stud and 16mm FR patch on each side
- The inclusion of cable bundles of up to 5 x CAT6 or 5 x TPS cables as tested in FSP 1729A specimen 2.
- The inclusion of cable bundles of up to 4 x CAT6 or 4 x TPS cables as tested in FSP 1795 specimen 2.
- Cables as tested in FRT 180323 R4.0 specimen H, with an increase sealant size to 50mm and the inclusion of 300mm Twrap on each side of penetration.
- The inclusion of cable bundles of up to 4 x CAT6 cables or 4 x 2C+E Prysmian cables or 4 x Firesense TP cables as tested in FRT 180323 R4.0 specimen G, with a maximum gap between cable and wall to be 5mm and an increase in sealant fillet size to 50mm.
- Inclusion of up to 4 x 6mm OD RG6 coax cables as tested in FSP 2249 specimen 4 installed in various wall types with annular gaps no greater than 5mm:
  - o 75mm single mesh AAC, Fyreflex sealant to the full depth of the wall and 30mm x 30mm fillet on each side
  - o 75mm double mesh AAC, Fyreflex sealant to the full depth of the wall and 30mm x 30mm fillet on each side

- 78mm Speedpanel, min. 130mm Masonry/concrete wall with Fyreflex sealant to the full depth of the wall and 30mm x 30mm fillet on each side
- 2 x min. 13mm layered plasterboard wall system, sealant to the full depth of lining and 30mm fillet sealant + 300mm Twrap on each side of the wall
- 1 x min. 13mm layered plasterboard wall system + 1 x min. 13mm FR patch on each side, sealant to the full depth of lining and 50mm fillet sealant on each side of the wall
- Wrap to be installed with overlap as per Figure 13
- The separation of the specimens shall be at least 40mm refer to Figure 5b
- Addition of various combinations of Eltech VRF cables (7mm total OD with 1.5mm diameter conductor, part number ELT7501P), installed in the following wall types
  - 120 minute 116mm or thicker plasterboard system
    - up to 6 x VRF cables
    - Protection as per 10 x TPS cables in 120mm thick plasterboard system
  - 90 minute 96mm or thicker plasterboard system
    - up to 5 x VRF cables
    - Protection as per 5 x TPS cables in 96mm thick plasterboard system
  - 90 minute 75mm or thicker Hebel panel
    - up to 4 x VRF cables
    - Protection as per 4 x TPS cables in 90 minutes 75mm Hebel panel
  - 120 minute 78mm or thicker Speedpanel
    - up to 4 x VRF cables
    - Protection as per 4 x TPS cables in 120 minutes 78mm thick Speedpanel
  - 90 minute 2x20mm Corex board lined wall including
    - up to 5 x VRF cables
    - annular gaps to be  $\leq 5$ mm and fully filled with Fyreflex sealant
    - 30mm x 30mm fillet of Fyreflex sealant on each side of the cable
    - 300mm Twrap on each side of the cable
  - 120 minute 2x25mm Corex board lined wall including
    - up to 5 x VRF cables
    - annular gaps to be  $\leq 5$ mm and fully filled with Fyreflex sealant
    - 30mm x 30mm fillet of Fyreflex sealant on each side of the cable
    - 300mm Twrap on each side of the cable

### **FP 11935 specimen 3**

The proposed construction comprises the inclusion of min. 75mm thick double caged Hebel wall, 78mm thick Speedpanel wall and min. 120mm thick concrete or 130mm thick masonry walls as barriers penetrated by FP 11935 specimen 3.

With reference to FP 11935 specimen 3, Appendix A D1 cables penetrated a 60mm thick vertically orientated blue Maxilite barrier. The specimen did not fail integrity for the 180-minute duration of the test and failed insulation on the cable tray at 144 minutes.

The proposed double caged reinforced AAC panel wall and Speedpanel wall system are both thicker than the tested barrier, and therefore will increase the heat conduction path on the cable tray, allowing the cable tray to be cooler on the unexposed side.

Provided that the proposed double caged reinforced AAC panel wall and Speedpanel wall system have a tested or assessed FRL of -/120/120, it is expected that the wall barrier will be able to maintain insulation for up to 120 minutes.

The proposed masonry/concrete wall is of greater thickness than the tested barrier, which will result in a greater heat conduction path along with the services and a greater heat sink effect that will draw heat away from the services. Both factors will enable the cable and cable trays to be cooler on the unexposed side.



Confidence in the ability of the masonry wall to perform for the required FRL is offered by reference to AS 3700-2018 clause 6.5, where the required wall thicknesses by that standard are the same as those proposed for the given FRL.

Based on the above, it is expected that the proposed construction will achieve an FRL of -/120/120 when installed in min. 75mm thick double caged Hebel wall and min. 78mm thick Speedpanel wall. It will also achieve an FRL of -/180/120 when installed in min. 120mm thick concrete or 130mm thick masonry walls when tested in accordance with AS 1530.4 – 2014 and assessed in accordance with AS 4072.1 -2005.

#### ***FRT 180392.1 specimen J***

The proposed construction comprises the inclusion of cable bundles of up to 10 x CAT 6 or 10 x TPS cables as tested in FRT 180392.1 specimen J installed in a 116mm thick plasterboard lined stud wall.

With reference to FRT 180392.1 specimen J, 5 x TPS cables 2.5mm<sup>2</sup>(5.29mm x 12.1mm) and 5 x CAT6 cables. (5.75mm diameter) penetrated a 116mm thick plasterboard lined stud wall. The specimen was able to maintain integrity and insulation for the 130 minutes duration of the test. The temperature rise measured at 120 minutes was 78°C on the Twrap and 59°C on the TPS cable and 47°C on the CAT 6 cable.

Typically, the ratio of copper conductors to the plastic sheath is greater in TPS cables than in CAT6 cables. This is evident in the higher temperature rise measured on the TPS cable compared to the CAT 6 cable in FRT 180392.1 specimen J.

The proposed bundles of up to 10 x CAT 6 cables would greatly increase the amount of plastic content going through the penetration, which may be a flaming risk. However, given the relatively low temperature measured on the specimen as well as the absence of any integrity failure at 130 minutes, it is expected that the increase in plastic content will not result in flaming failure for up to 120 minutes.

The proposed bundles of up to 10 x TPS cables would greatly increase the amount of copper conductor going through the penetration, which will increase the overall specimen temperature. However, given the low temperature measured on the TPS cable and on the Twrap at 120 minutes, it is expected that the doubling of copper conductor content will not result in insulation failure for up to 120 minutes.

Based on the above, it is expected that the proposed construction will achieve an FRL of -/120/120 when tested in accordance with AS 1530.4 – 2014 and assessed in accordance with AS 4072.1 -2005.

#### ***Up to 6 VRF cables***

The proposed construction comprises up to 6 VRF cables penetrating in a 116mm thick plasterboard lined stud wall protected in the same manner as FRT 180392.1 specimen J.

The proposed VRF cables are of similar construction to the tested CAT 6 cables in that it comprises stands of copper wire protected with PVC sheath and bundled inside PVC insulation, However, VRF cables are slightly larger in copper wire diameter and overall cable. Therefore it is expected that the VRF cables are more conductive than the CAT 6 cables.

Since the proposed number of VRF cables is much less than that tested in FRT 180392.1 specimen J, it is expected that the large margin in performance will allow these cables to perform in the same manner as the cables discussed above.

Based on the above, it is expected that the proposed construction will be able to maintain integrity and insulation for up to 120 minutes when tested in accordance with AS 1530.4 – 2014 and assessed in accordance with AS 4072.1 -2005.

#### ***FRT 180392.1 specimen C***

The proposed construction comprises the inclusion of cable bundles of up to 8 x 3C+E power cables as tested in FRT 180392.1 specimen C, with a maximum gap between cable and wall to be 20mm.



With reference to FRT 180392.1 specimen C, 8 x 18mm OD 3C+E Power 16mm<sup>2</sup> penetrated a 116mm thick plasterboard lined stud wall, protected on each side with a 300mm length of Twrap. The specimen was able to maintain integrity and insulation for the 130 minutes duration of the test. The temperature rise measured at 120 minutes was 93°C on the Twrap and 93°C on the cables.

The proposed decrease in the number of cables in the penetration would decrease the amount of plastic and copper conductor content, leading to a decrease in flame risk and also a decrease in the temperature rise of the cables on the unexposed side.

Based on the above, it is expected that the proposed construction will achieve an FRL of -/120/120 when tested in accordance with AS 1530.4 – 2014 and assessed in accordance with AS 4072.1 -2005.

#### ***FP 6033 specimen 8***

The proposed construction comprises the inclusion of cable bundles of up to 3 x 19 mm OD, 3C+E power cables as tested in FP 6033 specimen 8.

With reference to FP 6033 specimen 8, 3 x 19 mm, OD 3C+E 16mm<sup>2</sup> power cables penetrated a 90mm thick plasterboard lined stud wall. The specimen was able to maintain integrity for the 92 minutes duration of the test and failed insulation on the wall at 68 minutes. The temperature rise measured at 90 minutes was 240°C on the sealant and 220°C on the cables.

The proposed decrease in the number of cables in the penetration would decrease the amount of plastic and copper conductor content, leading to a decrease in flame risk and also a decrease in the temperature rise of the cables on the unexposed side.

Based on the above, it is expected that the proposed construction will achieve an FRL of -/60/60 when tested in accordance with AS 1530.4 – 2014 and assessed in accordance with AS 4072.1 -2005.

The proposed construction comprises the inclusion of cable bundles of up to 3 x 19 mm OD, 3C+E power cables as tested in FP 6033 specimen 8 penetrating a min. 96mm thick plasterboard lined stud wall lined with a layer of 16mm fire rated plasterboard on each side of the stud.

The proposed increase in plasterboard lining thickness will increase the depth of sealant on each side of the wall by 3mm, which will marginally improve the integrity performance of the seal.

The combined effect of a slightly thicker plasterboard wall barrier and the additional 300mm Twrap on each side of the wall will greatly extend the conduction path of the service such that the temperature rise to be measured at 90 minutes on the cable will be less than 180°C.

Provided that the proposed plasterboard wall system has a tested or assessed FRL of -/90/90, it is expected that the wall barrier will be able to maintain insulation for up to 90 minutes.

Based on the above, it is expected that the proposed construction will achieve an FRL of -/90/90 when tested in accordance with AS 1530.4 – 2014 and assessed in accordance with AS 4072.1 -2005.

The proposed construction comprises the inclusion of cable bundles of up to 3 x 19 mm OD, 3C+E power cables as tested in FP 6033 specimen 8 penetrating a min. 96mm thick plasterboard lined stud wall lined with a layer of 16mm fire rated plasterboard on each side of the stud, and with 16mm FR patch on each side and gap around cable in plasterboard to be 20mm.

It is expected that the increase in gap size will balance the increased depth of sealant such that the penetration will maintain integrity and insulation for up to 90 minutes.

Based on the above, it is expected that the proposed construction will achieve an FRL of -/90/90 when tested in accordance with AS 1530.4 – 2014 and assessed in accordance with AS 4072.1 -2005.

### ***FSP 1729A specimen 2***

The proposed construction comprises the inclusion of cable bundles of up to 5 x CAT6 or 5 x TPS cables as tested in FSP 1729A specimen 2.

With reference to FSP 1729A specimen 2, 3 x TPS power cables and 2 x Cat 6 cables penetrated a 96mm thick plasterboard lined stud wall. The specimen was able to maintain integrity for the 121 minutes duration of the test and failed insulation on the wall at 94 minutes. The temperature rise measured at 90 minutes was 165°C on the wall and 105°C on the cables.

Typically, the ratio of copper conductors to the plastic sheath is greater in TPS cables than in CAT6 cables. This is evident in the higher temperature rise measured on the TPS cable compared to the CAT 6 cable in FSP 1729A specimen 2.

The proposed bundles of up to 5 x CAT 6 cables would greatly increase the amount of plastic content going through the penetration, which may be a flaming risk. However, given the relatively low temperature measured on the specimen as well as the absence of any integrity failure at 121 minutes, it is expected that the increase in plastic content will not result in flaming failure for up to 90 minutes.

The proposed bundles of up to 5 x TPS cables would greatly increase the amount of copper conductor going through the penetration, which will increase the overall specimen temperature. However, given the low temperature measured on the TPS cable at 90 minutes, it is expected that the increase of copper conductor content will not result in insulation failure for up to 90 minutes.

Based on the above, it is expected that the proposed construction will achieve an FRL of -/90/90 when tested in accordance with AS 1530.4 – 2014 and assessed in accordance with AS 4072.1 -2005.

### ***FSP 1795 specimen 2***

The proposed construction comprises the inclusion of cable bundles of up to 4 x CAT6 or 4 x TPS cables as tested in FSP 1795 specimen 2.

With reference to FSP 1795 specimen 2, 2 x CAT6 6.3mm diameter cables, and 2 x TPS cables 2.5mm<sup>2</sup> cables penetrated a 75mm thick AAC wall. The specimen was able to maintain integrity and insulation for the 96 minutes duration of the test. The temperature rise measured at 90 minutes was 110°C on the sealant and 147°C on the cables.

Typically, the ratio of copper conductors to the plastic sheath is greater in TPS cables than in CAT6 cables. This is evident in the higher temperature rise measured on the TPS cable compared to the CAT 6 cable in FSP 1795 specimen 2.

The proposed bundles of up to 4 x CAT 6 cables would greatly increase the amount of plastic content going through the penetration, which may be a flaming risk. However, given the relatively low temperature measured on the specimen as well as the absence of any integrity failure at 96 minutes, it is expected that the increase in plastic content will not result in flaming failure for up to 90 minutes.

The proposed bundles of up to 4 x TPS cables would greatly increase the amount of copper conductor going through the penetration, which will increase the overall specimen temperature. However, given the low temperature measured on the TPS cable at 90 minutes, it is expected that the increase of copper conductor content will not result in insulation failure for up to 90 minutes.

Based on the above, it is expected that the proposed construction will achieve an FRL of -/90/90 when tested in accordance with AS 1530.4 – 2014 and assessed in accordance with AS 4072.1 -2005.

### ***FRT 180323 R4.0 specimen H***

The proposed construction comprises cables as tested in FRT 180323 R4.0 specimen H, with an increase in sealant fillet size to 50mm and the inclusion of 300mm Twrap on each side of penetration.

With reference to FRT 180323 R4.0 specimen H, 3 x 18mm OD 3C+E Power 16mm<sup>2</sup> cables penetrated a 78mm thick Speedpanel wall, protected by 30 x 30mm Fyreflex fillets on each side of the wall. The

specimen was able to maintain integrity for the 121 minutes duration of the test and failed insulation on the sealant at 46 minutes. The temperature rise measured at 120 minutes was 540°C on the sealant and 295°C on the cables.

The high temperature observed on the fillet of sealant is attributed to the venting of the moisture from the Speedpanel wall as its concrete core heats up. The proposed addition of Twrap will allow the temperature rise measured at 25mm away from the wall penetration to be no more than 180°C.

The proposed increase in sealant fillet size will improve the integrity performance of the seal. The proposed addition of 300mm of Twrap on each side of the wall will increase the heat conduction path of the cable such that the cables will be able to maintain insulation for up to 120 minutes.

Confidence in the ability of the Twrap to maintain insulation for up to 120 minutes is provided by FRT 180392.1 specimen C, where 8 x 18mm OD 3C+E Power 16mm<sup>2</sup> cables that penetrated a 116mm thick plasterboard lined stud wall were protected on each side with 300mm length of Twrap. The specimen was able to maintain integrity and insulation for the 130 minutes duration of the test. The temperature rise measured at 120 minutes was 93°C on the Twrap and 93°C on the cables.

The proposed construction has 5 fewer cables than that in FRT 180392.1 specimen C. Therefore, it is expected that the proposed cables and the Twrap will maintain insulation for 120 minutes.

Based on the above, it is expected that the proposed construction will achieve an FRL of -/120/120 when tested in accordance with AS 1530.4 – 2014 and assessed in accordance with AS 4072.1 -2005.

#### ***FRT 180323 R4.0 specimen G***

The proposed construction comprises cables as tested in the inclusion of cable bundles of up to 4 x CAT6 cables or 4 x 2C+E Prysmian cables or 4 x Firesense TP cables as tested in FRT 180323 R4.0 specimen G, with a maximum gap between cable and wall to be 5mm and an increase sealant fillet size to 50mm.

With reference to FRT 180323 R4.0 specimen G, 2 x CAT6 cables (5.75mm diameter), 2 x 2C+E cables 2.5mm<sup>2</sup> (6.21mm OD) and 2 x Firesense TP cable(5.1mm OD) penetrated a 78mm thick Speedpanel wall, protected by 30 x 30mm Fyreflex fillets on each side of the wall. The specimen was able to maintain integrity and insulation for the 121 minutes duration of the test. The temperature rise measured at 120 minutes was 148°C on the sealant and 120°C on the cables.

With reference to FSP 1729A specimen 2, 3 x TPS power cables and 2 x Cat 6 cables penetrated a 96mm thick plasterboard lined stud wall. The specimen was able to maintain integrity for the 121 minutes duration of the test and failed insulation on the wall at 94 minutes. The temperature rise measured at 120 minutes was 159°C on the sealant and 137°C on the cables.

The proposed number of cables is less than the total number of cables tested in FRT 180323 R4.0 specimen G. This means less plastic is in the penetration which will reduce the flaming risk of this specimen.

Also, the most conductive cable, 2C+E Prysmian cables are limited to 4 cables in total, which will result in a similar amount of conductive material as the cables tested in FSP 1729A specimen 2 which did not fail integrity nor insulation on the cable for 120 minutes.

The proposed wall barrier is slightly thinner than the wall tested in FSP 1729A specimen 2. Yet with the increase in sealant fillet size, the conduction path of the resultant cable is actually more than that tested in FSP 1729A specimen 2.

On balance, it is expected that the proposed construction will achieve an FRL of -/120/120 when tested in accordance with AS 1530.4 – 2014 and assessed in accordance with AS 4072.1 -2005.

*VRF cables in 96mm plasterboard wall, 75mm Hebel wall and 78mm speed panel wall*

The proposed construction comprises up to 5 VRF cables penetrating in a 96mm thick plasterboard lined stud wall, up to 4 VRF cables penetrating in a 75mm Hebel panel wall or 78mm Speedpanel wall, protected in the same manner as these wall types discussed above.

The proposed VRF cables are of similar construction to the tested CAT 6 cables in that it comprises stands of copper wire protected with PVC sheath and bundled inside PVC insulation, However, VRF cables are slightly larger in copper wire diameter and overall cable. Therefore it is expected that the VRF cables are more conductive than the CAT 6 cables.

It is expected that the large margin in performance will allow these cables to perform in the same manner as the cables discussed above.

Based on the above, it is expected that the proposed construction will be able to maintain integrity and insulation for up to 90 and 120 minutes based on design when tested in accordance with AS 1530.4 – 2014 and assessed in accordance with AS 4072.1 -2005.

#### ***FSP 2249 specimen 4***

The proposed construction comprises the inclusion of a minimum of 90mm thick plasterboard wall, 116mm thick plasterboard wall, min. 75mm thick single or double caged Hebel wall, 78mm thick Speedpanel wall and min. 120mm thick concrete or 130mm thick masonry walls as barriers penetrated by FSP 2249 specimen 4.

With reference to FSP 2249 specimen 4, 4 x 6mm OD RG6 coax cables penetrated a 75mm thick AAC panel, with sealant filled to the full depth of the panel and a 30mm fillet on each side of the cable. The specimens did not fail integrity or insulation for up to 121 minutes duration of the test.

The proposed 75mm single or double cage panel, 78mm Speedpanel and the 120mm thick concrete or 130mm thick masonry walls would all have the same or greater conduction path compared to the tested panel in FSP 2249 specimen 4. Therefore, it is reasonable to expect that the cables when installed in these walls, will be able to perform similarly or better.

The proposed 116mm plasterboard wall is thicker than the 75mm AAC wall tested in FSP 2249 specimen 4, which would increase the conduction path of the services. However, the wall has less moisture content and which would result in faster heating up of services.

Also, the proposed overall sealant depth is less than that tested in FSP 2249 specimen 4. However, the proposed fillet size is greater than that tested in FSP 2249 specimen 4.

On balance, with no signs of integrity or insulation failure at 120 minutes, it is expected that when FSP 2249 specimen 4 is installed in the proposed 116mm plasterboard wall, it will also maintain integrity and insulation for up to 120 minutes.

The proposed 90mm plasterboard wall is thicker than the 75mm AAC wall tested in FSP 2249 specimen 4, which would increase the conduction path of the services. However, the wall has less moisture content and which would result in faster heating up of services

Also, the proposed overall sealant depth is less than that tested in FSP 2249 specimen 4. However, the proposed fillet size is greater than that tested in FSP 2249 specimen 4.

On balance, with 60 minutes of margin in performance, it is expected that when FSP 2249 specimen 4 is installed in the proposed 90mm plasterboard wall, it will also maintain integrity and insulation for up to 60 minutes.

#### ***Confirmation of service spacing***

AS 4072.1 -2005 clause 4.9.3 states that “the minimum distance between penetrations in a modular system shall be not less than 40 mm unless otherwise tested in specimen form.” It is noted also in clause 1.4.10 which defines a “penetration” as “An aperture through a fire-separating element for the passage of a service or services”

Based on the above, it is considered that AS 4072.1 -2005 Amdt. 1 clause 4.9.3 is applicable to the specimens considered in this assessment. The minimum aperture to aperture spacing of the proposed specimens is 40mm.

## B.7 Inclusion of penetrations in Corex walls

The proposed construction comprises metal pipes tested in FRT 220112 subjected to the following variations;

- Addition of 90 minute Corex wall constructions (2x20mm Corex boards on steel stud) as tested in FRT 220112 when penetrated by the following services
  - o Steel and copper pipes up to 100mm with 600mm TWrap and 15mm fillets of FyreFLEX sealants based on FRT 220112 specimen G
  - o Steel and copper pipes up to 50mm with 300mm TWrap and 15mm fillets of FyreFLEX sealants based on FSP 2230 specimen 4
  - o Stainless steel pipe up to 100mm with 600mm Twrap, with a layer of 100mm width x 60mm Maxilite Pad or 3 layers of 100mm width x 20mm thick Corex boards Pad on one side
  - o Include three additional service penetrations that are protected as tested in FRT220112 specimen A and include one of the following cable types
    - Up to 30 x TPS cables 2.5mm<sup>2</sup>
    - Up to 30 x TPS fire 1.5mm<sup>2</sup>
    - Up to 30 x CAT6 cables,
  - o Include up to 8 x 19mm OD, 3C+E 16mm<sup>2</sup> power cables protected as tested in FRT220112 specimen E
- Addition of 120 minute Corex wall constructions (2x25mm Corex boards on steel stud) as tested in FRT 220112 when penetrated by the following services
  - o Steel and copper pipes up to 100mm with 600mm TWrap and 15mm fillets of FyreFLEX sealants based on FRT 220112 specimen G
  - o Stainless steel pipe up to 100mm with 600mm Twrap, with a layer of 100mm width x 60mm thick Maxilite Pad or 2 layers of 100mm width x 25mm thick Corex boards Pad on each side
  - o Include three additional service penetrations that are protected as tested in FRT220112 specimen A and include one of the following cable types
    - Up to 30 x TPS cables 2.5mm<sup>2</sup>
    - Up to 30 x TPS fire 1.5mm<sup>2</sup>
    - Up to 30 x CAT6 cables,
  - o Include up to 8 x 19mm OD, 3C+E 16mm<sup>2</sup> power cables protected as tested in FRT220112 specimen E

It is required that the proposed -/90/90 Corex wall constructions and -/120/120 Corex wall constructions be tested or assessed for an FRL of at least -/90/90 and -/120/120 when exposed to fire from each direction.

### **FRT 220112 specimen G**

With reference to FRT 220112 specimen G, a 100mm copper pipe penetrated a 40mm thick Corex board wall system and was protected with 600mm of Twrap on each side. When tested, the penetration was able to maintain integrity for the 121 minutes duration of the test and failed insulation on the wall at 92 minutes. The pipe and the wrap both were able to maintain insulation for at least 120 minutes. It was found that the thermocouple locations on the specimens were less onerous than that required by AS 1530.4 – 2014.

The proposed construction comprises the inclusion of copper and steel pipes up to 100mm protected in the same manner on each side of the wall RT 220112 specimen G, and be installed in a 40mm thick and 50mm thick Corex board wall system.

It is expected that the increase in wall thickness will allow the localised area around the penetration to also maintain insulation for longer. The proposed additional layer of wrap on the 100mm copper pipe will also improve the insulation performance on the wrap at the opening and therefore address the less onerous location of the thermocouple on FRT 220112 specimen G. Therefore it is expected that the installation of the proposed construction in a 50mm thick Corex wall will maintain insulation for up to 120 minutes.

As discussed above, it is expected that steel pipes of a similar diameter to copper pipe will perform in a similar manner.

Based on the above, it is expected that the proposed construction will be able to maintain integrity and insulation for up to 90 minutes and 120 minutes based on design when tested in accordance with AS 1530.4 – 2014 and assessed in accordance with AS 4072.1 -2005.

#### ***FSP 2230 specimen 4***

With reference to FSP 2230 specimen 4, a 50mm copper pipe penetrated a 41mm thick laminated plasterboard wall system and was protected with 300mm of Twrap on each side. When tested, the penetration was able to maintain integrity and insulation for the 98 minutes duration of the test.

The proposed construction comprises the inclusion of copper and steel pipes up to 50mm protected in the same manner on each side of the wall as in FSP 2230 specimen 4 though with a reduced size of sealant, and be installed in a 40mm thick Corex board wall system.

With 8 minutes of margin in performance, the 15mm reduction in fillet size of sealant, and the 1mm decrease in wall thickness, it is expected that the installation of the proposed construction in a 40mm thick Corex wall will maintain integrity and insulation for up to 90 minutes.

As discussed above, it is expected that steel pipes of a similar diameter to copper pipe will perform in a similar manner.

Based on the above, it is expected that the proposed construction will be able to maintain integrity and insulation for up to 90 minutes when tested in accordance with AS 1530.4 – 2014 and assessed in accordance with AS 4072.1 -2005.

#### ***Up to 100mm stainless steel pipe***

The proposed construction comprises the installation of stainless steel pipes of up to 100mm diameter installed in 40mm thick Corex wall systems and protected on each side with 600mm Twrap, as well as a layer of 100mm width x 60mm Maxilite Pad or 3 layers of 100mm width x 20mm thick Corex boards Pad on one side of the penetration.

The proposed construction also comprises the installation of stainless steel pipes of up to 100mm diameter installed in 50mm thick Corex wall systems and protected on each side with 600mm Twrap, as well as a layer of 100mm width x 60mm Maxilite Pad or 2 layers of 100mm width x 25mm thick Corex boards Pad on each side of the penetration.

With reference to FP 11935-001 specimen 1, this specimen demonstrated that a minimum 60mm thick panel wall system penetrated by a maximum 100mm diameter copper with 600mm Twrap and 50mm x 50mm fillet of sealant on each side, is able to maintain integrity at the seal for more than 180 minutes as well as maintaining insulation on the pipe for at least 120 minutes while the 60mm Maxilite barrier failed insulation at 88 minutes.

The proposed construction comprises a slight decrease in base wall thickness as well as a slight decrease in fillet size. With a 60 minutes to 90 minutes margin on integrity performance, it is expected that the proposed construction will be able to maintain integrity and insulation for up to 90 and 120 minutes.



Also, the proposed construction comprises an increase in the overall wall thickness at the penetration. This will act to increase the conduction path of the pipe, and therefore improve the overall insulation performance of the penetration.

An analysis of copper and stainless steel pipes was carried out based on the pipes of similar size installed in similar construction, and it was found that the copper pipe result from FP 11935-001 specimen 1 can be conservatively applied to stainless steel pipes in the proposed wall systems.

Based on the above, it is expected that the proposed construction will be able to maintain integrity and insulation for up to 90 minutes and 120 minutes based on design when tested in accordance with AS 1530.4 – 2014 and assessed in accordance with AS 4072.1 -2005.

#### ***FRT220112 specimen A***

The proposed construction comprises the inclusion of cable bundles of up to 30 x TPS cables 2.5mm<sup>2</sup> or up to 30 x TPS fire 1.5mm<sup>2</sup> or up to 30 x CAT6 cables, protection as tested in FRT 220112 specimen A when installed in a 40mm or a 50mm thick Corex wall system.

With reference to FRT 220112 specimen A, the 40mm thick Corex wall was penetrated by a bundle of 10 x 12mm x 5mm TPS cables 2.5mm<sup>2</sup>, 10 x 7mm OD TPS fire 1.5mm<sup>2</sup> and 10 x 6mm OD CAT6 cables, seal on each side with 50mm x 50mm fillet of sealant and wrapped on each side with 300mm length of Twrap. The penetration failed on the wall at 103 minutes while maintaining insulation on the cables and the wrap for up to 120 minutes. It was found that the thermocouple locations on the specimens were less onerous than that required by AS 1530.4 – 2014.

Given that there were no signs of impending integrity failure at 120 minutes, and low temperature observed on the cables at 120 minutes and based on the discussions above, it is reasonable to apply this result to the proposed construction for up to 120 minutes.

Based on the above, it is expected that the proposed construction will be able to maintain integrity and insulation for up to 90 minutes and 120 minutes based on design when tested in accordance with AS 1530.4 – 2014 and assessed in accordance with AS 4072.1 -2005.

#### ***FRT 220112 specimen E***

The proposed construction comprises the inclusion of cable bundles of up to 8 x 19mm OD, 3C+E 16mm<sup>2</sup> power cables, protection as tested in FRT 220112 specimen E when installed in a 40mm or a 50mm thick Corex wall system.

With reference to FRT 220112 specimen E, the 40mm thick Corex wall was penetrated by a bundle of 8 x 19mm OD, 3C+E 16mm<sup>2</sup> power cables, seal on each side with 50mm x 50mm fillet of sealant and wrapped on each side with 300mm length of Twrap. The penetration failed on the wall at 103 minutes while maintaining insulation on the cables and the wrap for up to 120 minutes. It was found that the thermocouple locations on the specimens were less onerous than that required by AS 1530.4 – 2014.

Given that there were no signs of impending integrity failure at 120 minutes, and low temperature observed on the cables at 90 minutes and based on the discussions above, it is reasonable to apply this result to the proposed construction for up to 90 minutes when the thermocouples are in the location as required by AS 1530.4 -2014.

It is expected that the increase in wall thickness will allow the localised area around the penetration to also maintain insulation for longer. The proposed additional layer of wrap will also improve the insulation performance on the wrap at the opening and therefore address the less onerous location of the thermocouple on FRT 220112 specimen G. Therefore it is expected that the installation of the proposed construction in a 50mm thick Corex wall will maintain insulation for up to 120 minutes.

Based on the above, it is expected that the proposed construction will be able to maintain integrity and insulation for up to 90 minutes and 120 minutes based on design when tested in accordance with AS 1530.4 – 2014 and assessed in accordance with AS 4072.1 -2005.



### VRF cables

The proposed construction comprises up to 5 VRF cables penetrating in a 40mm or a 50mm thick Corex wall system, seal on each side with 30mm fillets, and protected on each side with 300mm Twrap.

The proposed VRF cables are of similar construction to the tested CAT 6 cables in that it comprises stands of copper wire protected with PVC sheath and bundled inside PVC insulation, However, VRF cables are slightly larger in copper wire diameter and overall cable. Therefore it is expected that the VRF cables are more conductive than the CAT 6 cables.

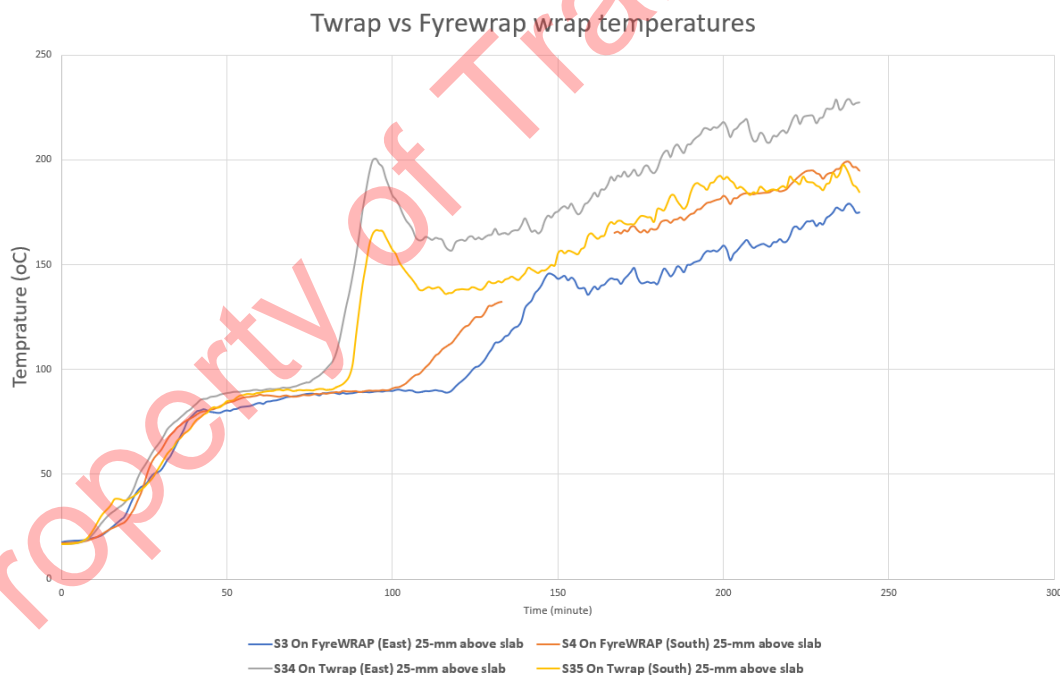
Since the proposed number of VRF cables is less than that tested in FRT220112 specimen A, it is expected that the large margin in performance will allow these cables to perform in the same manner as the cables discussed above, despite having a slightly smaller fillet of sealant.

Based on the above, it is expected that the proposed construction will be able to maintain integrity and insulation for up to 90 minutes and 120 minutes based on design when tested in accordance with AS 1530.4 – 2014 and assessed in accordance with AS 4072.1 -2005.

## B.8 Optional use of Firewrap in place of Twrap

The proposed variation comprises the substitution of Firewrap where Twrap wrapped is used in the penetrations proposed in this assessment.

With reference to FSP 2146 specimens 1 and 4, which comprised 100mm copper pipes wrapped either in 600mm length of Firewrap or Twrap respectively on the unexposed side of a 150mm thick concrete slab. Specimen 4, which was the pipe with Twrap flued at 86 minutes while specimen 1, which was the pipe with Firewrap flued at 138 minutes. Neither specimen showed any integrity failure associated with the wrap or penetration seal for up to 241 minutes duration of the test.



**Figure B2: Wrap temperatures in FSP 2146**

The test was designed to compare the performance of Firewrap and Twrap. With reference to Figure B2, prior to these pipes fluing, the insulation performance of the wraps was similar, with Twrap heating up slightly faster than Firewrap before they both plateaued in temperature rise to just under 100°C at around 50 minutes. During the fluing of the pipes, it was observed that Twrap also heated up faster than Firewrap as shown by the steeper gradient of the Twrap temperature peak. After fluing of the pipes, the Twrap and Firewrap temperature rise was again similar.

Therefore, it is reasonable and conservative to expect that when copper pipe which flued in FSP 2146 specimen 1, was wrapped with Fyrewrap, it would have also performed similarly to or marginally better than specimen 4 (Twrap) for up to 180 minutes.

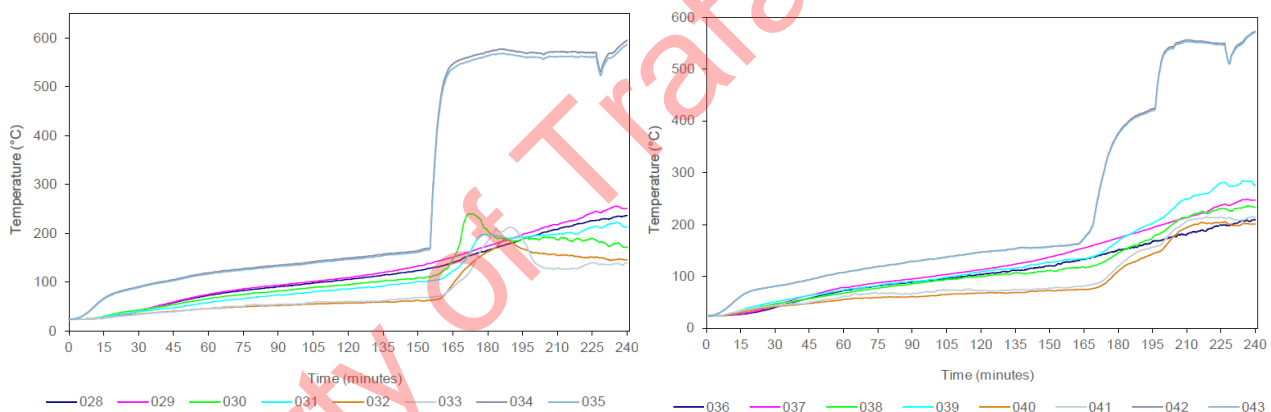
With reference to FSP 2146, both Twrap and Fyrewrap have demonstrated their ability to not caused flaming for up to 240 minutes. Since a 100mm copper pipe was used as the standard heating element for the comparison of these wraps, its high rate of heat transfer ability allows the above comparisons to be applicable to other penetrations mentioned in this report.

Based on the above, it is expected that when the penetrations discussed in sections B2, B3, B5 and B6 are wrapped with Fyrewrap instead of Twap, it would not detrimentally affect the insulation performance of the proposed penetrations for up to 180 minutes and their integrity performance for up to 240 minutes when tested in accordance with AS 1530.4 – 2014 and assessed in accordance with AS 4072.1 -2005.

## B.9 Optional use of Monowrap in place of Twrap

The proposed variation comprises the substitution of Monowrap where Twrap wrapped is used in the proposed service installed in slabs for up to 120 minute applications as discussed in this assessment.

With reference to FRT 210467, specimen F comprised 40mm diameter copper pipes protected with Monowrap at a 300mm length above a 150mm thick slab while specimen G comprised 40mm diameter copper pipes protected with Twrap at a 300mm length above a 150mm thick slab. Neither specimen showed any integrity failure associated with the wrap or penetration seal for up to 240 minutes duration of the test. The thermocouple temperatures of these specimens are shown in Figure B3.



**Figure B3: FRT 210467 specimens F and G temperatures (Monowrap left, Twrap right)**

The test was designed to compare the performance of Monowrap and Twrap. With reference to Figure B3, before the specimen pipe flued, the temperature profiles on the wrap and pipes are similar, with the Monowrap temperature at 120 minutes being slightly lower than the Twrap temperature.

With reference to FRT 210467, both Twrap and Monowrap have demonstrated their ability to not caused flaming for up to 240 minutes when protecting services penetrating a slab and wrapped from above.

Based on the above, it is expected that when the penetrations discussed in Sections B2 and B5 (floors) are wrapped with Monowrap instead of Twap, it would not detrimentally affect the insulation performance of the proposed penetrations for up to 120 minutes and their integrity performance for up to 240 minutes when tested in accordance with AS 1530.4 – 2014 and assessed in accordance with AS 4072.1 -2005.

## B.10 Optional additional fillet of Fyreflex sealant

The proposed construction comprises the inclusion of an optional additional 30mm x 30mm fillet of Fyreflex at the base of wrapped services and the support construction as per Figure 5.

The addition of sealant is expected to improve the performance of the services slightly as it moves the thermocouples on the wrap further away from the wall.

Based on the above, it is expected that when the penetrations discussed in sections B2, B3, B5 and B6 are treated with the additional sealant, it would not detrimentally affect the performance of the proposed penetrations for up to 240 minutes when tested in accordance with AS 1530.4 – 2014 and assessed in accordance with AS 4072.1 -2005.

Property of Trafalgar Group

CONTACT US

**t** 1300 363 400  
+61 3 9545 2176  
**e** enquiries@csiro.au  
**w** www.csiro.au

YOUR CSIRO

Australia is founding its future on science and innovation. Its national science agency, CSIRO, is a powerhouse of ideas, technologies and skills for building prosperity, growth, health and sustainability. It serves governments, industries, business and communities across the nation.

FOR FURTHER INFORMATION

**Infrastructure Technologies**

Keith Nicholls  
Team Leader - Fire Assessments  
**t** +61 2 94905450

**e** keith.nicholls@csiro.au

**w** <https://research.csiro.au/infratech/fire-safety/fire-testing/>

Brett Roddy

Group Leader | Infrastructure Technologies North Ryde

**t** +61 2 94905449

**e** brett.rodny@csiro.au

**w** <https://research.csiro.au/infratech/fire-safety/fire-testing/>

Property of Trafalgar Group