

# FyreSET®

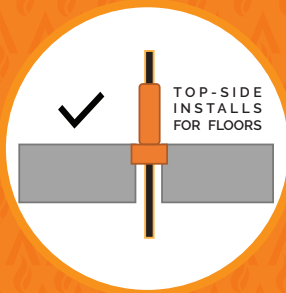

FyreSET® Mortar is an Australian Made special cement based mixture formulated specifically for fire rating applications, in particular openings in fire barriers that include complicated or mixed service penetration types.



## KEY FEATURES



- Perfect for high FRL applications up to -/240/240
- Effective heat sink for small 'wrap free' cable penetrations
- Easily mixed on site
- Surface mounted or flush set
- Allows for a neat install
- Fire tested for use with FyreBOX™ Cast-In systems
- Fire tested to AS1530.4-2014

## APPLICATIONS



Electricians	Power
	Data Cables PVC Conduits
Fire Professionals	Sprinkler Pipes
	Fire Cables
Plumbers	Copper and Steel Pipes

## TRADES

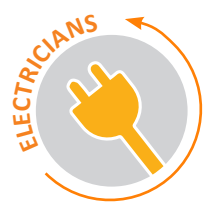



# TABLE OF CONTENTS



Section		Page
	Overview	3
	Compliance	4
	Fire Resistance Level	5
FRL Tables	Electrical/Comms Cable	6
	Copper Pipes	7
Installation	Surface Mounted and Z-Clips	8
	Preparing	9
	FyreFLEX® Sealant and TWRAP™	10
	FyreBOX™ Cast-In with FyreSET®	11
	System Range	12
	FAQ	13
Technical Drawing	FyreSHIELD Plus - Ceiling Details	14-18

# FyreSET®

## WHAT IS FyreSET®?

Trafalgar Fire FyreSET® Mortar is a cement-based mixture formulated specifically for fire rating applications, in particular openings in fire barriers that include complicated or mixed service penetration types. FyreSET® Mortar is easily mixed on site with water to a required consistency for either pouring or trowelling into floor slab penetrations. FyreSET® Mortar has been fire tested in numerous configurations and with a multitude of service penetration types as required by the National Construction Code, providing FRLs up to-/240/240 (system dependent).

FyreSET® Mortar can be installed as a surface-mounted or flush-set (backfilled) system and has been fire tested with a range of cable and metal pipe service penetrations to AS1530.4-2014. FyreSET® Mortar has over 30 years of proven performance in Australia's harshest building site conditions, giving confidence in long-term integrity and compliance and is ready for NCC 2022 requirements.

## APPLICATIONS

FyreSET® Mortar systems are suitable for use in any building where penetrations are made through concrete floor slabs with large openings. They have been tested and approved for the following services:

- Cable trays up to 600mm with power and data
- Cable bundles with TPS, CAT6 and Firesense cables
- Copper pipes
- Steel pipes
- PVC Conduits (with FyreCHOKE Conduit Collars)
- FyreBOX™ Cast-In, for multiple services including insulated pipes and PEX pipes, etc.

## SPECIFICATIONS

Specification	Detail
Weight	10kg
Density	850kg/m <sup>3</sup>
Curing time	24-48 hours
Mixing	4-6 litres of water
VOC and ODP	Low
Loadbearing	No, take measures to prevent foot traffic over all penetrations



# FyreSET® NCC2022 READY



## COMPLIANCE WITH THE NATIONAL CONSTRUCTION CODE (NCC)

Formerly known as BCA

Under the building code, a Deemed to Satisfy (DTS) solution is one that satisfies the performance requirements set out in section C of volume one. Section C specifically deals with the fire protection of openings in fire barriers (i.e. service penetrations in fire rated walls and floors).

### Section C3.15 - Openings for Service Installations

Where any service penetrates a fire barrier that has a Fire Resistance Level (FRL) with respect to integrity and insulation, the installation should comply with: A Fire Tested System - An identical prototype, installed in the same wall or floor system that has been tested/approved to the fire testing standard AS1530.4 and AS4072.1 which has achieved an FRL of equal to greater than that required by the fire barrier.

For example, if the site has a -/120/120 plasterboard wall system with an electrical conduit penetration, the product used to seal the cables must have been fire tested at an approved laboratory WITH the conduit filled with electrical cables IN the same wall type AND tested for at least 120 minutes without failing the integrity or insulation criteria.

*Compliance will only be achieved when the installation on site mirrors the tested system.*

## TEST AND ASSESSMENT REPORTS

Fire testing is a timely and expensive process, and it is impossible to test every single possible service configuration 'identically' in a practical sense. Under the building code C3.15(a)(i)(B) a testing authority is permitted to write a formal assessment conforming the likely fire performance (FRL) of the penetration. The guidelines for what can and can't be included in a formal assessment are outlined in AS4072.1.

For copies of our most recent test reports from a NATA approved laboratory in accordance with AS1530.4-2014, for use as evidence of compliance please visit [tfire.com.au](http://tfire.com.au) or contact [technical@tgroup.com.au](mailto:technical@tgroup.com.au) for more details.

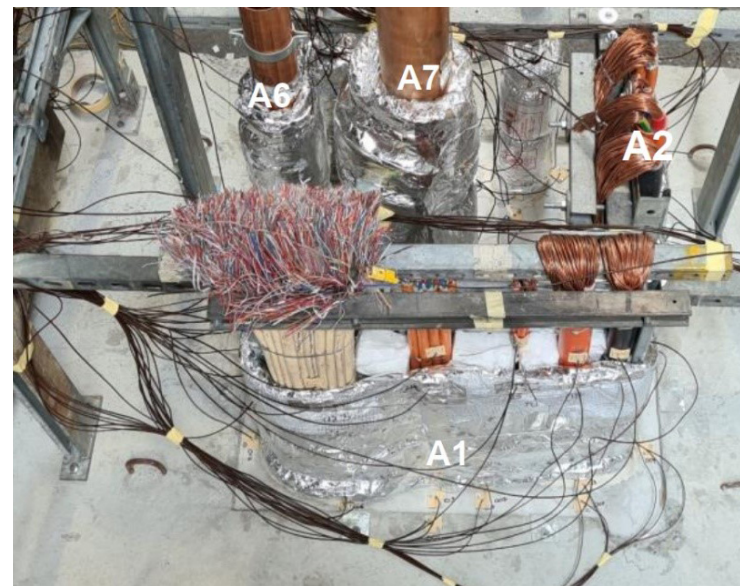

# FyreSET®

## FIRE RATING – HOW IS FIRE PERFORMANCE MEASURED?

An FRL (fire resistance level) is a handy way of summarising the performance of a building element. It consists of 3 numbers, all given in minutes:

### FRL 240/240/240

(example)



#### Structural Adequacy

The ability of the building element to support the weight of adjacent building elements.

ie: a brick wall supporting a concrete floor slab above.



#### Integrity

The ability of an element to prevent the passage of flames and hot gasses.

ie: a plasterboard wall remaining intact and not allowing holes to form.

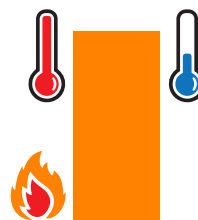

#### Insulation

The ability of an element to resist heat transfer from the exposed face to the unexposed face.

ie: a bundle of cables remaining below a set temperature limit on the unexposed side of the wall penetration system.

*Note: Penetrations are not required to have a Structural Adequacy rating and is usually expressed as a dash. For example, a penetration through a 2 hour load bearing wall would be written as -/120/120.*

## INTEGRITY

The FyreSET® system will achieve the integrity performance for up to 4 hours physically stopping the direct spread of fire, however the insulation performance of the penetration will be limited to the type of barrier being used and conductivity of the services in the penetration.

## INSULATION (TEMPERATURE RISE)

Heat transfer via conduction (or heat rise) will occur through the conductive parts of any penetration system. To limit heat rise through the FyreSET® Mortar penetration systems, our 25mm thick TWRAP™ foil encased blanket can be wrapped around the services and to achieve up to 4 hours of insulation performance. There are some applications that won't require any TWRAP™ to achieve the full FRL, please refer to the tables below for specific details.

## FRL Approvals Tables

# ELECTRICAL/COMMS CABLE

## Floor Penetrations



Mortar Thickness	Service Type	Service Specification	FRL Acheived	TWRAP Length	Test Reference
100mm	Cable bundles* (or single)	Bundle of 10x TPS power	-/240/180	Wrap Free	FRT 200255 FRT 200256
		Bundle of 10x CAT6 data cables	-/240/180	Wrap Free	
		Bundle of 10x Firesense cables (2.5mm <sup>2</sup> )	-/240/180	Wrap Free	
		Bundle of 8x power cables in a bundle (bundles spaced 50mm apart)	-/240/120	450mm	
		180mm <sup>2</sup> three core Earth cables approx. 42mm OD (cable spaced 50mm apart)			
	630mm <sup>2</sup> single core cables approx. 53mm OD (cable spaced 50mm apart)				
	Cable trays*	Up to 600mm (with above cables)	-/120/120	450mm	
Up to 300mm with power cables only		-/240/120	450mm		
Up to 300mm with power cables only, against a		-/240/180	450mm	FRT 200256	
150mm	Single Cables	Up to 32mm OD Aluminium core cables	-/240/120	Wrap Free	NI 1388**
	Cable Trays	Up to 300mm with CAT6, TPS or Firesense cables	-/240/120	Wrap Free	FAS 200221

\* Testing from AS1530.4-2014 Appendix D1 and D2 cable sets

\*\* Testing to AS1530.4-2005

All cable are copper core unless stated otherwise, and may be cast directly into FyreSET® Mortar.  
 All cable penetrations require a 50 x 50mm fillet of FyreFLEX® sealant to the top side for the floor slabs.

## FRL Approvals Tables

### COPPER PIPES

#### Floor Penetrations



Mortar Thickness	Service Specification (up to size)	FRL Achieved	TWRAP Length	Test Reference
100mm	DN32 type B copper pipe	-/90/90	300mm	FAS 200424
	DN50 type B copper pipe	-/240/120	450mm	FRT 200256
	DN80 type B copper pipe	-/90/90	600mm	FRT 200255
	DN100 type B copper pipe	-/120/120	800mm	FRT 200255
	DN150 type B copper pipe	-120/120	1200mm (with additional 300mm second layer at the base)	FRT 200118

### STEEL PIPES

#### Floor Penetrations



Mortar Thickness	Service Specification (up to size)	FRL Achieved	TWRAP™ Length	Test Reference
100mm	Up to 50NB steel pipe	-/240/120	450mm	FRT 200256
	Up to 100NB steel pipe	-/240/240	450mm	FRT 200256
	Up to 150NB steel pipe	-/120/120	1200mm (with additional 300mm second layer at the base)	FRT 200118
150mm	Up to 100NB steel pipe	-/240/240	450mm	FRT 200256 FRT 190292

Metal Pipes should not be cast directly into mortar/concrete. Cast pipes into place with backing rod or other removable material to set an annular gap ranging from 5-20mm that can be sealed with FyreFLEX® sealant to a depth of 60mm. All installations for pipes require a 50x50mm fillet of FyreFLEX® sealant to the top side for the FRLs listed.

# INSTALLATION

## OPTION 1 - SURFACE MOUNTED HOB

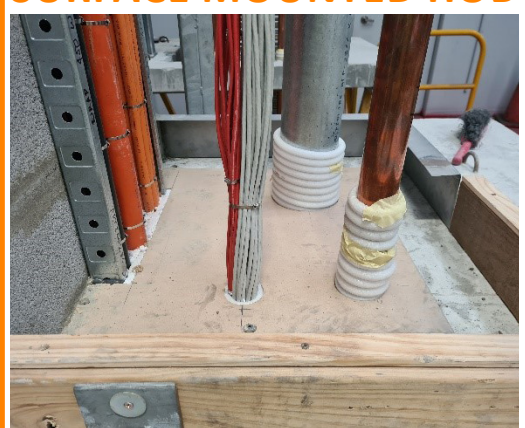

Form up the top side of the slab with MDF, then build up the formwork for the hob ensuring that the mortar will overlap the base MDF by at least 100mm. It is generally best practice to use permanent steel Z brackets for mechanical protection. **Max size 450 x 450 mm.**

## OPTION 2 - FLUSH MOUNTED

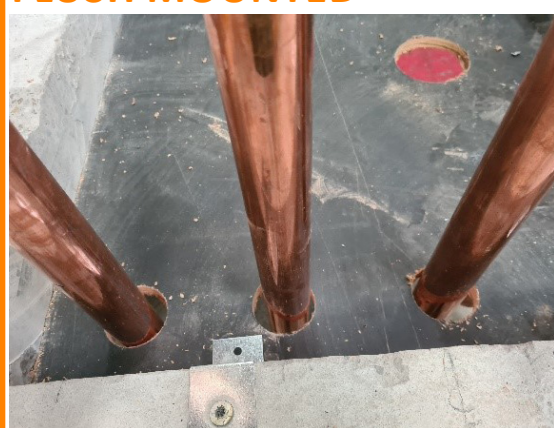

Form up the opening from below, or at a suitable depth so that FyreSET® mortar can be backfilled from the top side to the correct depth. **Max size 800 x 800mm.**

*If temporary formwork is used around a surface mounted system, it must be removed, and the perimeter of the hob sealed with FyreFLEX® sealant fillet 25 x 25mm.*

## FIT Z-CLIPS



When using the flush mounted mortar system, Z-clips are essential to key the mortar into the slab to ensure life safety as well as fire performance.

## FIT Z-CLIPS CO

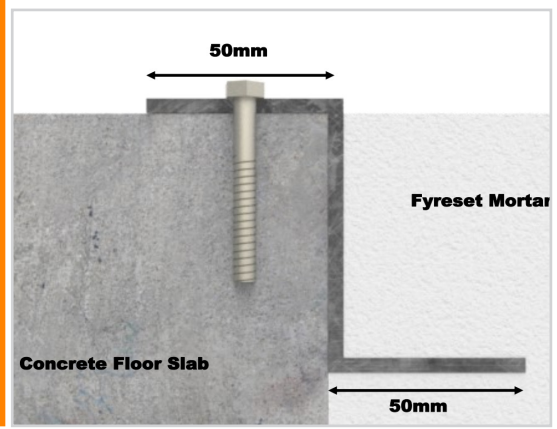

Z-clips are a light gauge Z-shaped steel bracket sized to suit the depth of mortar, and should be bolted to the slab with M6 x 40mm concrete anchors at 300mm centres.



# INSTALLATION

## PREPARE METAL PIPES



Ensure that there is an annular gap formed to allow the pipe system to expand due to thermal expansion, vibration or slab movement.

Wrap PE backing rod or other similar material around the pipes before pouring mortar for a quick, effective and easily removable solution.

## PREPARE CABLE/CABLE



Cable trays and cable bundles can be cast directly into the mortar. PVC conduits must have a 25mm FyreCHOKE Conduit Collar installed to the top side of the formwork to be cast into place.

Stuff small gaps in the formwork with cardboard or other material to prevent mortar from pouring through.

*Check the approvals tables in this manual for details of the FyreFLEX® Sealant Fillets (size requirements). Ensure services maintain 50mm of separation in the FyreSET® system.*

## MIX & POUR



For a pourable mix Trafalgar Fire recommends approx. 4-5L of water for each 10kg bag. Mix in well.

For floor penetrations, it is important to ensure a wet mix to allow the mortar to flow into small openings/crevices. Be sure to fill lips of cable trays.

## CURE



Allow mortar to cure. Typically 24 hours is enough to begin FyreFLEX® Installation.

# INSTALLATION

## FyreFLEX® Sealant



Remove any backing rods from around the services and apply FyreFLEX® sealant as per the FRL tables from [pages 7-9](#). For metal pipes, ensure sealant is backfilled to the correct depth.

## TWRAP™



Wrap services with TWRAP™ for the required distance off the floor slab as per the FRL tables. Strap in place with 4.6mm Steel cable ties 50mm from each end, and 200mm centres.

*If the required FRL is without insulation (e.g. -/240/-), contact Trafalgar Fire for more 'wrap-free' solutions.*

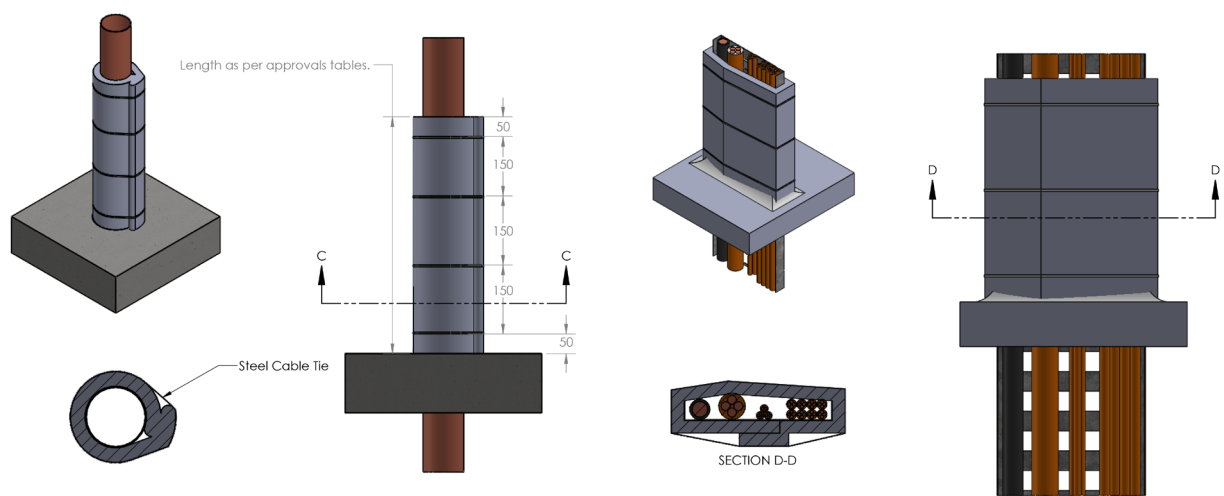

**Note:**

- Each 300mm width of Twrap has a 50mm overlap onto itself around the service.
- 4.6mm wide stainless steel cable ties 50mm from each end, and at 150mm centres in between.

**NOTE:**

- Each 300mm width of TWrap has a 50mm overlap onto itself round the service.
- 4.6mm wide stainless steel cable ties 50mm from each end, and at 150mm centres in between

## FyreBOX™ Cast-In with FyreSET®

The Trafalgar Fire FyreBOX™ Cast-In is approved in 120mm depth FyreSET® Mortar. For a multiple penetration system with a mixed variety of services, refer to the [FyreBOX™ Cast-In Technical Manual](#) for listings of tested services, FRLs and TWRAP™ details.

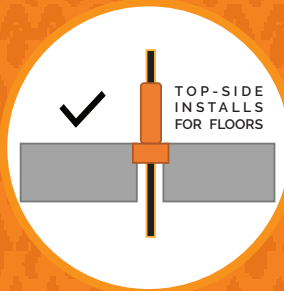

### KEY FEATURES

- Cast into slab to save time in construction
- Allows multiple and mixed services to pass through one opening
- Mixed services approved in any quantity or configuration
- Space saving, eliminates the need for 200mm separation between adjacent services
- Fire tested in independent laboratories
- Thoroughly tested to AS1530.4-2014

### APPLICATIONS

<b>Electricians</b>	Power Data cables Conduits
<b>Plumbers</b>	Steel and Copper pipes PVC pipes PEX pipes PEX-AL-PEX pipes
<b>HVAC&amp;R</b>	Insulated pipes
<b>Active Fire</b>	Sprinkler pipes Fire cables

### TRADES



## SYSTEM RANGE



- 75mm for 2 hours
- Non-Load Bearing

CLICKABLE CODES

Item Number	Size	Colour	Pallet Qty
FyreSET 10	10kg	Grey	64 Bags
Z-Brackets H90	1.1mm Gal- 50 x 90 x 50mm - Width 50mm	-	Each
Z-Brackets H160	1.1mm Gal- 50 x 160 x 50mm - Width 50mm	-	Each

## FyreSET® SYSTEM COMPONENTS

CLICKABLE CODES

Item Number	Description	Min Order Qty	Pallet QTY
FyreFLEX 300W FyreFLEX 300G	FyreFLEtX Sealant Cartridge 300ml White or Grey	1	1920
FyreFLEX 600W FyreFLEX 600G	FyreFLEX Sealant Sausage 600ml White or Grey	1	1040
FyreFLEX 10G	FyreFLEX® sealant Pail 10L Grey	1	64
TWrap 300	300mm wide, 25mm thick blanket	7620mm long roll	24
TWrap 450	450mm wide, 25mm thick blanket	7620mm long roll	12
TWrap 600	600mm wide, 25mm thick blanket	7620mm long roll	12

## FAQ

**Q How many bags of FyreSET® Mortar do I need for my BxWxH cm opening?**

**A** Bag quantity = (BxWxH in centimetres) divided by 14000.

**Q Can I walk over the opening once it has set?**

**A** FyreSET® Mortar is not load bearing, please take the appropriate precautions to ensure the mortar is not treated as trafficable.

**Q Do I need to use fire rated sealant?**

**A** Yes. You need to seal around the services with a fillet of FyreFLEX® sealant.

**Q Do I need to use permanent formwork for my mortar installation?**

**A** No, formwork can be removed if the mortar is installed using Z-brackets to secure the mortar fill. Contact Trafalgar Fire for more details.

**Q Can I leave my timber formwork in place after the install is complete?**

**A** Combustible formwork can be left on the exposed face with no detriment to the FRL achieved.

**Q Can I use FyreSET® Mortar to fire-stop plastic pipes and conduits?**

**A** Yes, FyreCHOKE Micro Collars have been tested, cast into FyreSET® Mortar for 25mm size PVC.

**Q Can I have cables at the edge of the opening?**

**A** Yes - FyreSET® Mortar has been tested with cables both centred and at the edges of the opening.

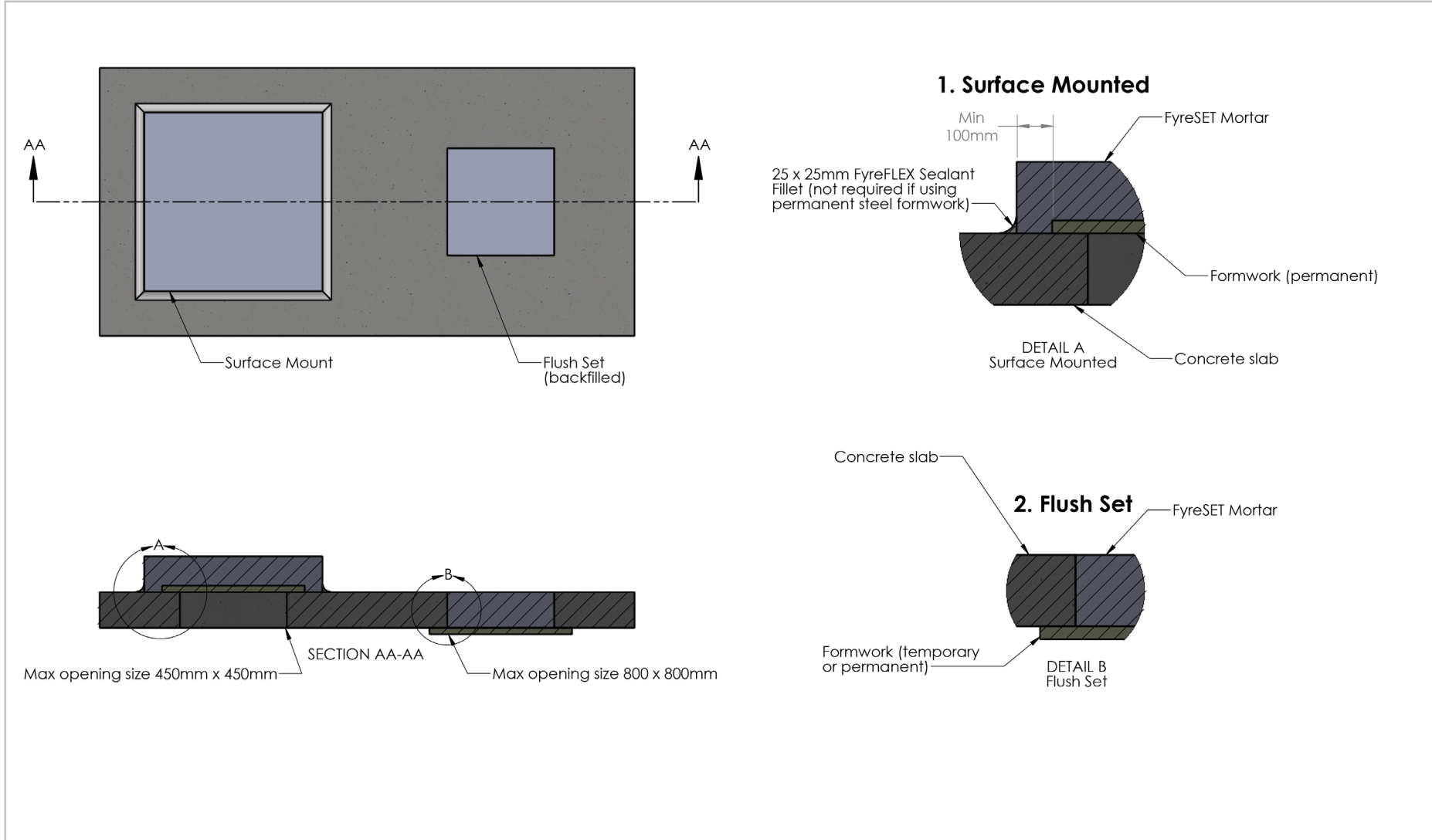

<b>Drawing Name:</b> Fill Types				<b>Test Standard:</b> AS1530.4	<b>Codes:</b>	<b>Revision:</b>	<b>Date:</b>	<b>No.:</b>	<b>NOTICE:</b>
<b>Project Title:</b> FyreSET Mortar Installation Drawing				<b>Fire resistance level:</b>	<b>Drawn By:</b> SM	<small>NOTE: ALL DIMENSIONS ARE IN MILLIMETRES (mm).</small>			
<b>Drawing No. :</b> 1	<b>Sheet:</b> 1 of 3	<b>Date:</b> 7/12/2020	<b>Scale:</b> NTS	<b>Based on Report No.:</b>	<b>Checked By:</b> JH	<input type="checkbox"/> STANDARD DRAWING	 <small>Trafalgar Head Office: PO BOX 545 Chester Hill NSW 2162 T: 1800 888 714 F: 1800 201 500 E: technical@tgroup.com.au W: www.fire.com.au</small>		
						<input type="checkbox"/> PROJECT DRAWING			

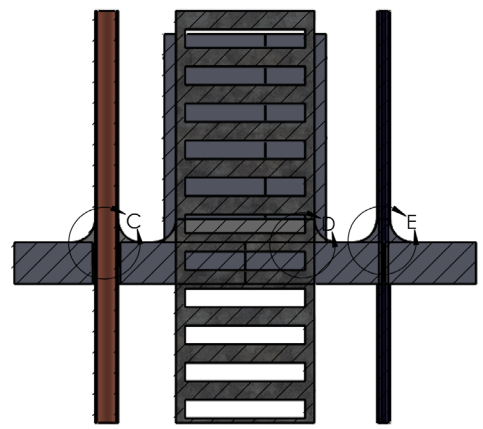
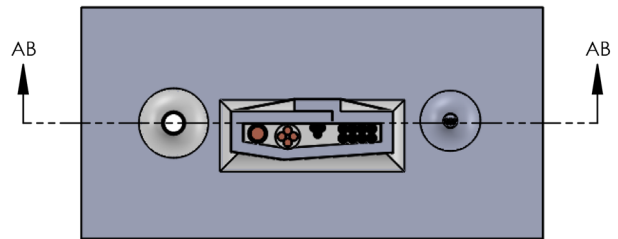

SECTION AB-AB

**1. Metal Pipe**

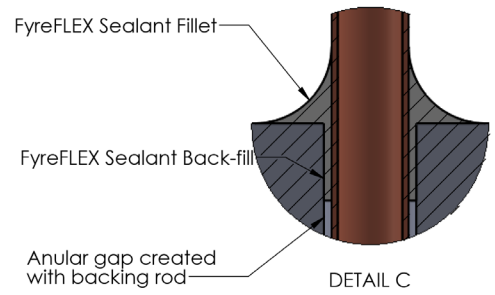

DETAIL C

**2. Cable Tray**

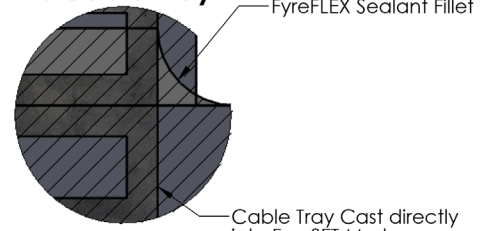

DETAIL D

**3. Cable Bundle**

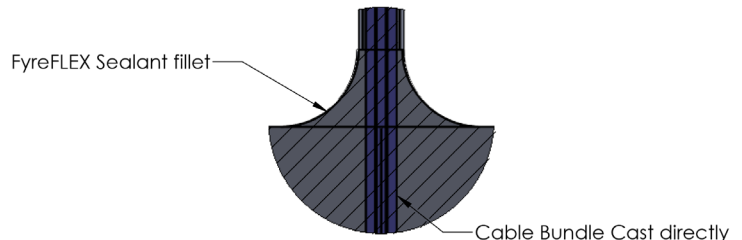

DETAIL E

**Drawing Name:** Service Installation

**Project Title:** FyreSET Mortar Installation Drawing

**Drawing No. :**  
2

**Sheet:**  
2 of 3

**Date:**  
7/12/2020

**Scale:**  
NTS

**Test Standard:**  
AS1530.4

**Fire resistance level:**

**Based on Report No.:**

**Codes:**

**Drawn By:**  
SM

**Checked By:**  
JH

**Revision:**

**Date:**

**No.:**

NOTE: ALL DIMENSIONS ARE IN MILLIMETRES (mm)

Trafalgar Head Office:  
PO BOX 545  
Chester Hill NSW 2162  
T: 1800 888 714  
F: 1800 201 500  
E: technical@tgroup.com.au  
W: www.tfire.com.au

STANDARD DRAWING  
 PROJECT DRAWING



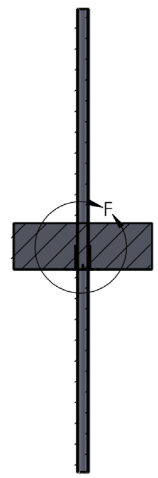

SECTION AC-AC

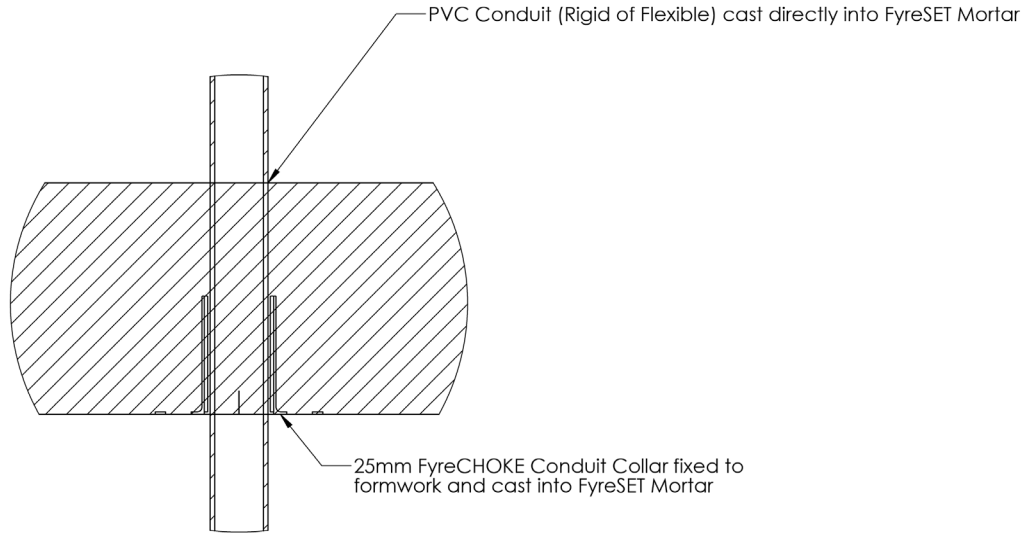

DETAIL F

<b>Drawing Name:</b> FyreCHOKE Collar				<b>Test Standard:</b> AS1530.4	<b>Codes:</b>	<b>Revision:</b>	<b>Date:</b>	<b>No.:</b>	<b>NOTICE:</b>
<b>Project Title:</b> FyreSET Mortar Installation Drawing				<b>Fire resistance level:</b>	<b>Drawn By:</b> SM	<small>NOTE: ALL DIMENSIONS ARE IN MILLIMETRES (mm)</small>			
<b>Drawing No. :</b> 3	<b>Sheet:</b> 3 of 3	<b>Date:</b> 7/12/2020	<b>Scale:</b> NTS	<b>Based on Report No.:</b>	<b>Checked By:</b> JH	<input type="checkbox"/> STANDARD DRAWING	 <b>TRAFALGAR FIRE</b> PO BOX 545 Chester Hill NSW 2162 T: 1800 888 714 F: 1800 201 500 E: technical@group.com.au W: www.tfire.com.au		
<input type="checkbox"/> PROJECT DRAWING									



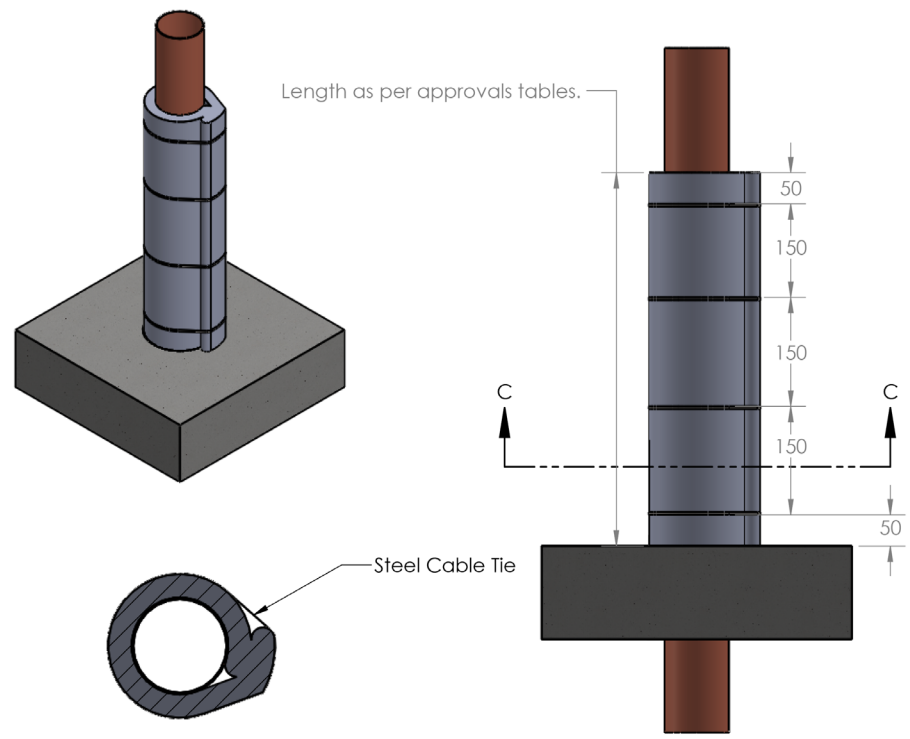



**Note:**

- Each 300mm width of TWrap has a 50mm overlap onto itself around the service.
- 4.6mm wide stainless steel cable ties 50mm from each end, and at 150mm centres in between.

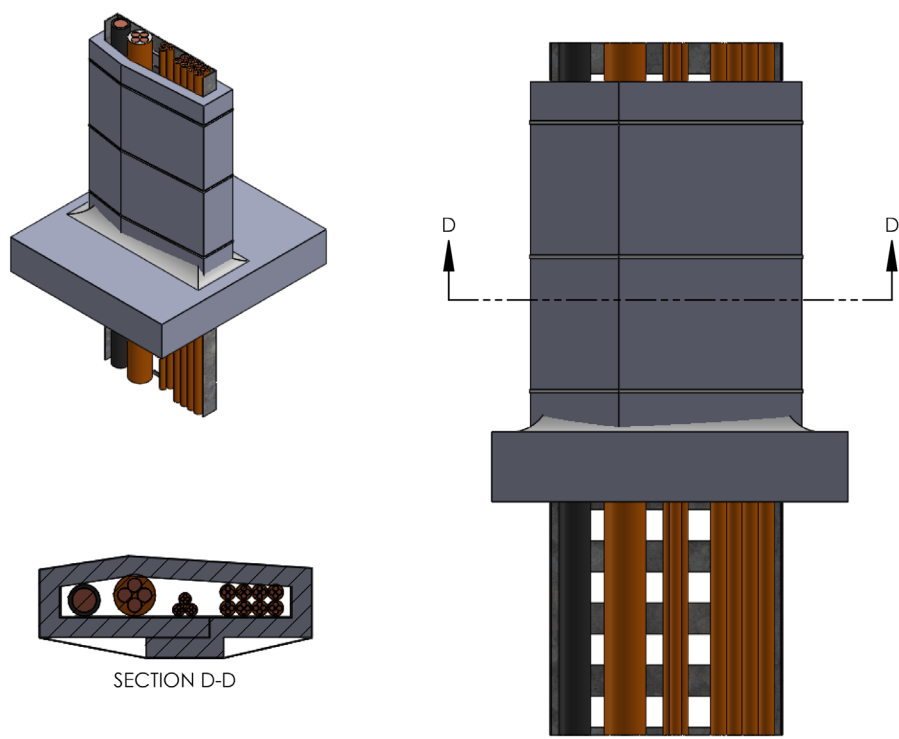
<b>Drawing Name:</b> TWrap detail			<b>Test Standard:</b> AS1530.4	<b>Codes:</b>	<b>Revision:</b>	<b>Date:</b>	<b>No.:</b>	<b>NOTICE:</b>
<b>Project Title:</b> Wrap Drawing			<b>Fire resistance level:</b>	<b>Drawn By:</b> SM	<small>NOTE: ALL DIMENSIONS ARE IN MILLIMETRES (mm)</small> <b>Trafalgar Head Office:</b> PO BOX 545 Chester Hill NSW 2162 T: 1800 888 714 F: 1800 201 500 E: info@tfire.com.au W: www.tfire.com.au			
<b>Drawing No. :</b> 1	<b>Sheet:</b> 1 of 2	<b>Date:</b> 1/12/2020	<b>Scale:</b> NTS	<b>Based on Report No.:</b>				



- NOTE:**
- Each 300mm width of TWrap has a 50mm overlap onto itself round the service.
  - 4.6mm wide stainless steel cable ties 50mm from each end, and at 150mm centres in between

<b>Drawing Name:</b> TWrap Detail Cont.				<b>Test Standard:</b> AS1530.4	<b>Codes:</b>	<b>Revision:</b>	<b>Date:</b>	<b>No.:</b>	<b>NOTICE:</b>
<b>Project Title:</b> Wrap Drawing				<b>Fire resistance level:</b>	<b>Drawn By:</b> SM	<small>NOTE: ALL DIMENSIONS ARE IN MILLIMETRES (mm)</small>  <b>TRAFALGAR FIRE</b> Trafalgar Head Office: PO BOX 545 Chester Hill NSW 2162 T: 1800 888 714 F: 1800 201 500 E: technical@tgroup.com.au W: www.tfire.com.au			
<b>Drawing No. :</b> 2	<b>Sheet:</b> 2 of 2	<b>Date:</b> 1/12/2020	<b>Scale:</b> NTS	<b>Based on Report No.:</b>	<b>Checked By:</b> JH				