

FyreWrap® Access Panel

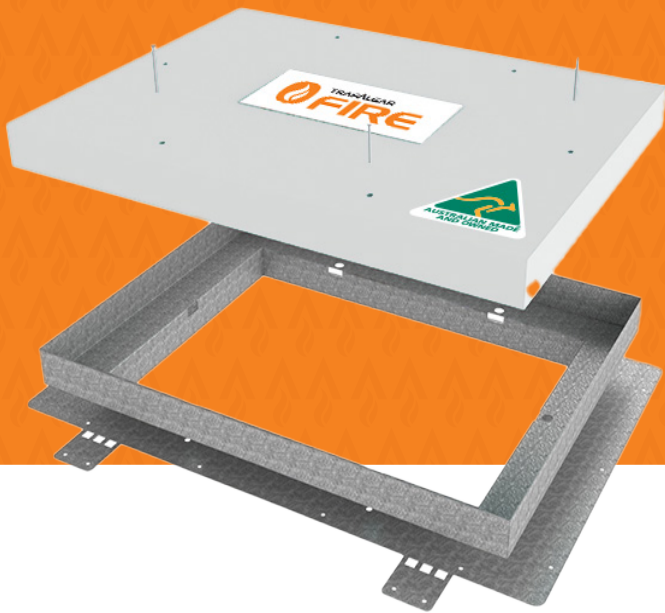

FyreWrap® Access Panels are a patented system designed for use on ducts protected by the innovative FyreWrap® system. These panels form part of a fully certified system to AS1530.4 to provide fire ratings on ducts and allow access easily and quickly. The patented design allows for easy installation and use and with various stock and custom sizes available the product can be widely used.

KEY FEATURES



- Provides fast clean and easy access to fire protected ducts
- Sized to fit over existing duct access panels
- FRL up to 180/180/180
- Welded steel frame with flexible fastening tabs
- Screw fixing with machine screws for robust access
- Available in custom sizes

APPLICATIONS



Provides access to duct work for:

- Inspection
- Service
- Repair
- Replacement of internal equipment:
 - Filters
 - Volume Control Devices
 - Dampers
 - Fans

TRADES



FyreWrap® is a registered Trademark of Unifrax

TABLE OF CONTENTS



| Section | | Page |
|--------------------|--|------|
| | Product Overview | 1 |
| | Fire Resistance Level | 3 |
| | Specifications | 4 |
| Installation | FyreWrap® Access Panels - Profile Detail | 5 |
| | FyreWrap® Access Panels | 6 |
| | System Range | 7 |
| | FAQ | 8 |
| Technical Drawings | Access Panel Details | 9 |
| | Fan Enclosure - Front View | 10 |
| | Fan Enclosure - Side View | 11 |
| | Out of Line Damper | 12 |

FyreWrap® Access Panel

Fire Rating – How is fire performance measured?

An FRL (fire resistance level) is a handy way of summarising the performance of a building element. It consists of 3 numbers, all given in minutes. Ductwork uses a different FRL than other applications, shown below:

FRL 180/180/180

(example)



Structural Adequacy

The duct will maintain its size and shape allowing operation.



Integrity

The ability of an element to prevent the passage of flames and hot gases.

ie: no gases or flame passing in or out of the duct.



Insulation

The ability of an element to resist heat transfer from the exposed face to the unexposed face.

ie: the temperature inside or outside the duct (dependency on test type) staying below the limit.

Structural Adequacy

FyreWrap® will allow structural adequacy up to 3 hours (external fire) or 3 hours (internal fire). Unprotected supports are possible with FyreWrap® due to its lightweight nature.

Integrity

The FyreWrap® system will achieve the integrity performance of 3 hours (external fire) or 3 hours (internal fire)

Insulation (Temperature Rise)

FyreWrap® can achieve up to 3 hours insulation performance for internal and external fires with options for one or more layers depending on the FRL requirement.

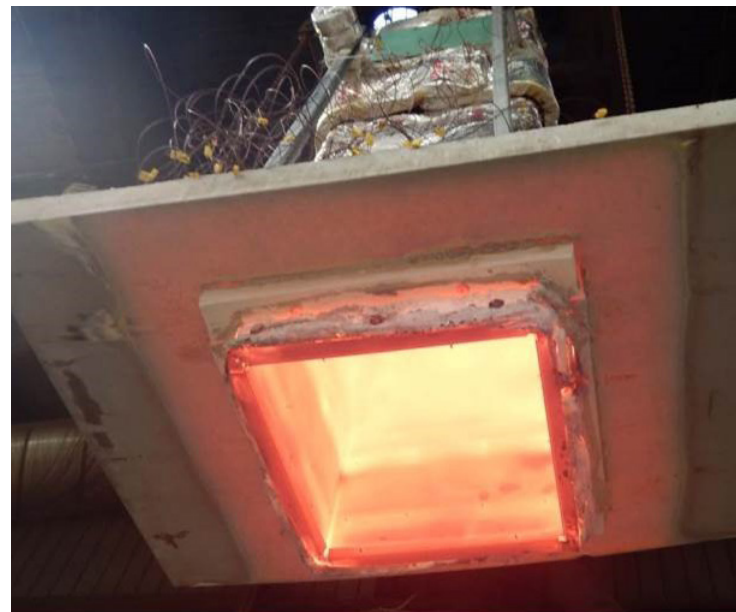

Note: FyreWrap® Access Panels are tested for internal fire applications only.

FyreWrap® Access Panel

- Patented design with features that ensure complete flexibility and ease of installation.
- Are simply installed by fitting directly over the existing 'non-rated duct access panel' and fixed to the duct using rivets through a series of pre-drilled holes.
- Provide additional flexibility on site as they can be either pre-installed or easily retro-fitted.
- Include patented, bendable fastening tabs for slimline ducts to allow access without the need for a full box encasement.

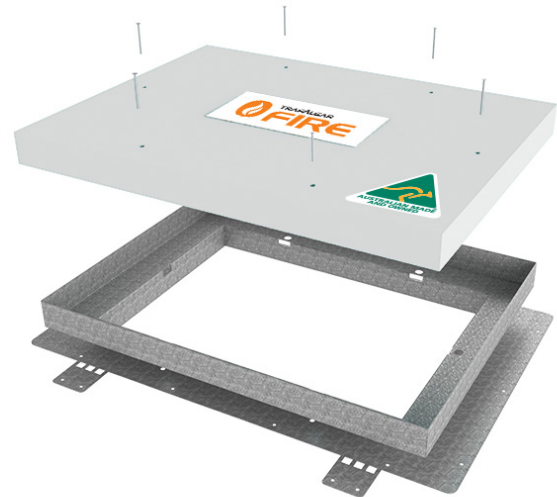

SPECIFICATIONS

| | | |
|---|-------------|--|
|  | Fire Rating | 180/180/180 |
| | Door Panel | Paint grade white hardboard incorporating FyreBOARD Maxilite® high performance fire rated board. |
| | Frame | Welded galvanised steel featuring patented and bendable fastening tabs. |
| | Fixing | Screw fixed using reusable machine screw fixings which are an integral part of the design. |
| | Sizes | 708mm x 558mm 558mm x 433mm 433mm x 301mm 304mm x 214mm Custom up to 708mm x 558mm |

INSTALLATION

FyreWrap® ACCESS PANELS

PROFILE DETAIL

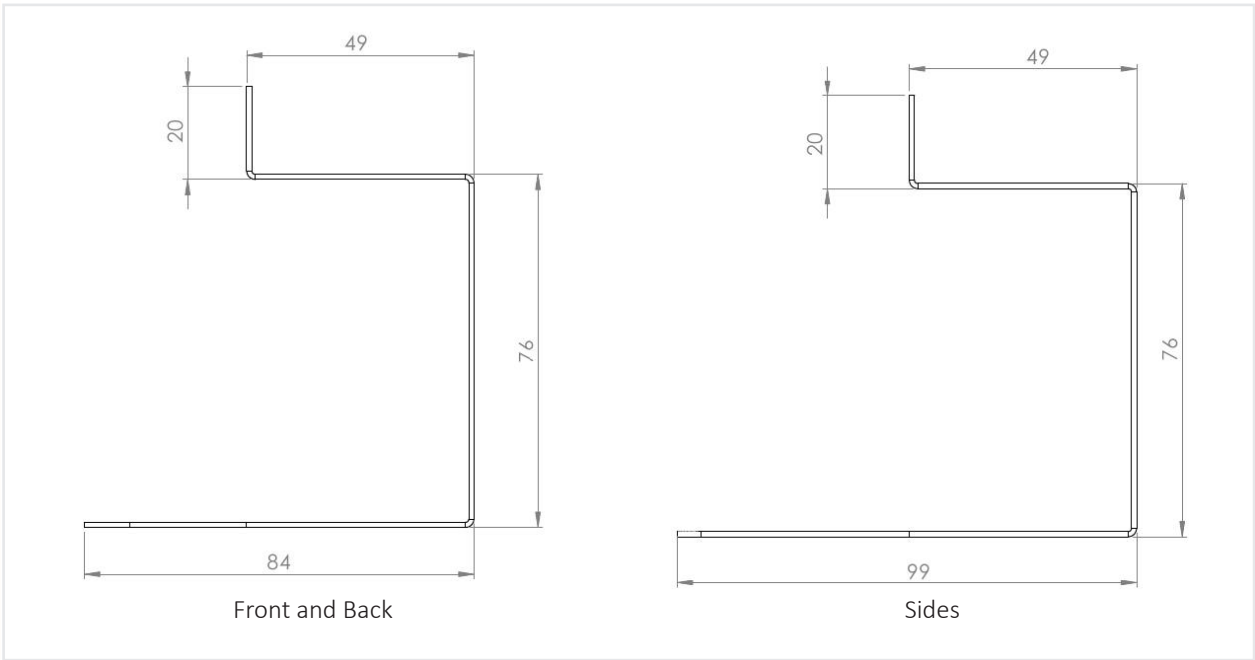

PREPARE

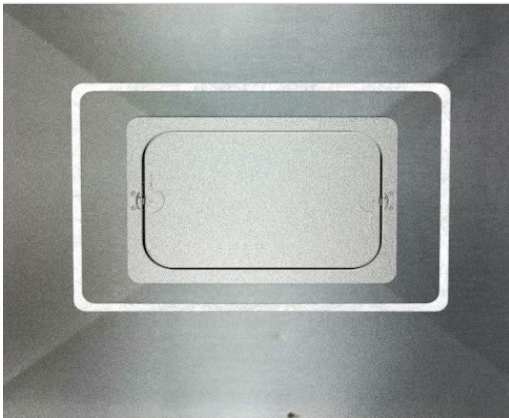

Apply FyreFLEX Sealant around the perimeter of the duct access panel to form a 'gasket' where the FyreWrap® access panel will sit.

FIX



Using the preformed holes in the FWAP frame, drill and fix (using steel rivets or self-tapping screws only) the frame to the ductwork.

- * Fixings are required at maximum 150mm spacing.
- * If required for low profile ductwork, the top and bottom fold-over tabs can be folded over and fixed through the top/bottom side of the ducting.

INSTALLATION

FyreWrap® ACCESS PANELS

FyreWrap® FIRST LAYER



Install FyreWrap® Elite 1.5 according to FyreWrap® installation instructions, ensuring that the material fits snugly into the provided recess in the FWAP frame on all sides. See the [FyreWRAP® Ductwork Technical Manual](#) for more details.

FyreWrap® SECOND LAYER



Install a second layer of FyreWrap® Elite 1.5, 100mm wide on all sides of the FyreWrap® Access Panel, fixing as per the standard FyreWrap® Elite 1.5 installation requirements (steel strapping or welded pins at 200mm centres).

TAPE EDGES

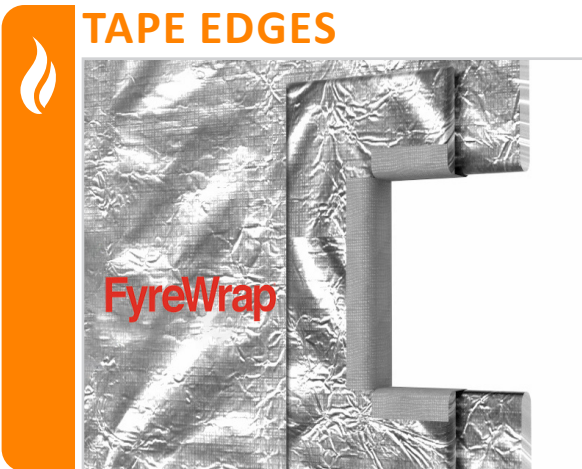

Tape the edges of both layers of FyreWrap® Elite 1.5 together.

FINISH



Finish the installation with a fillet of FyreFLEX Sealant to the perimeter of the FyreWrap® Access Panel, ensuring that none of the metal frame remains exposed.

FyreWrap® ACCESS PANEL

- Provides fast clean and easy access to fire protected ducts
- Sized to fit over existing duct access panels
- FRL up to 180/180/180
- Welded steel frame with flexible fastening tabs
- Screw fixing with machine screws which are an integral part of the product design
- Available in custom sizes

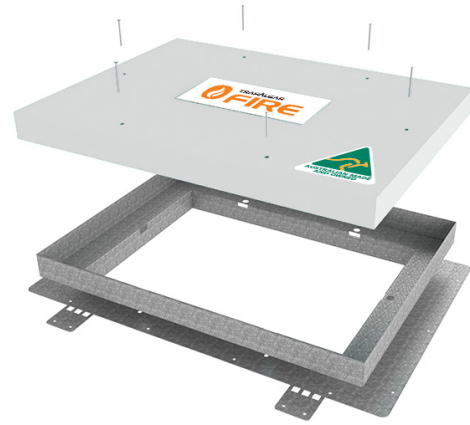

| Item Number | Size | To Suit | FyreWrap® System | Qty | Pallet Qty |
|-----------------|-------------------------------|---------|------------------|-----|------------|
| FW-AP-2L-AP0 | 708mm x 558mm | AP0 | 2 Layer | 1 | 10 Panels |
| FW-AP-2L-AP1 | 558mm x 433mm | AP1 | 2 Layer | 1 | 10 Panels |
| FW-AP-2L-AP2 | 433mm x 301mm | AP2 | 2 Layer | 1 | 30 Panels |
| FW-AP-2L-AP3 | 304mm x 214mm | AP3 | 2 Layer | 1 | 40 Panels |
| FW-AP-2L-CUSTOM | Custom Up to 708mm x 558mm | Custom | 2 Layer | 1 | - |

FyreWrap® ACCESS PANEL SYSTEM

| Item Number | Size | Thickness | Qty | Pallet Qty |
|--------------------------------|---|-----------|--------|------------|
| FyreFLEX 300W FyreFLEX 300G | FyreFLEX Sealant Cartridge 300ml White or Grey | - | 1 | 1920 |
| FyreFLEX 600W FyreFLEX 600G | FyreFLEX Sealant Sausage 600ml White or Grey | - | 1 | 1040 |
| FyreWrap® Elite 610 | 610mm wide x 7620mm long | 38mm | 1 roll | 12 rolls |
| FyreWrap® Elite 1220 | 1220mm wide x 7620mm long | 38mm | 1 roll | 6 rolls |

FAQ?

Q What sizes do the panels come in?

A There are a number of stock sizes to suit typical applications (AP0, AP1, etc...), however custom sizes are also available.

Q Do I need any other products?

A Simply FyreFLEX® Sealant for use in installation.

Q Do I need to remove the existing duct access panel?

A No, the FyreWrap® Access Panel fits directly over the existing panel.

Q How hard is it to open the panel?

A The panel is secured to the framing using steel machine screws for quick and easy access.

Q Can FyreWrap® Access Panels be used on ducts that have been treated with a spray product?

A No, the FyreWrap® Access Panel must be used in conjunction with FyreWrap® Elite. See the [FyreWrap® Ductwork Technical Manual](#) for more information.

SOCIAL MEDIA



FyreWrap® Access Panel Details

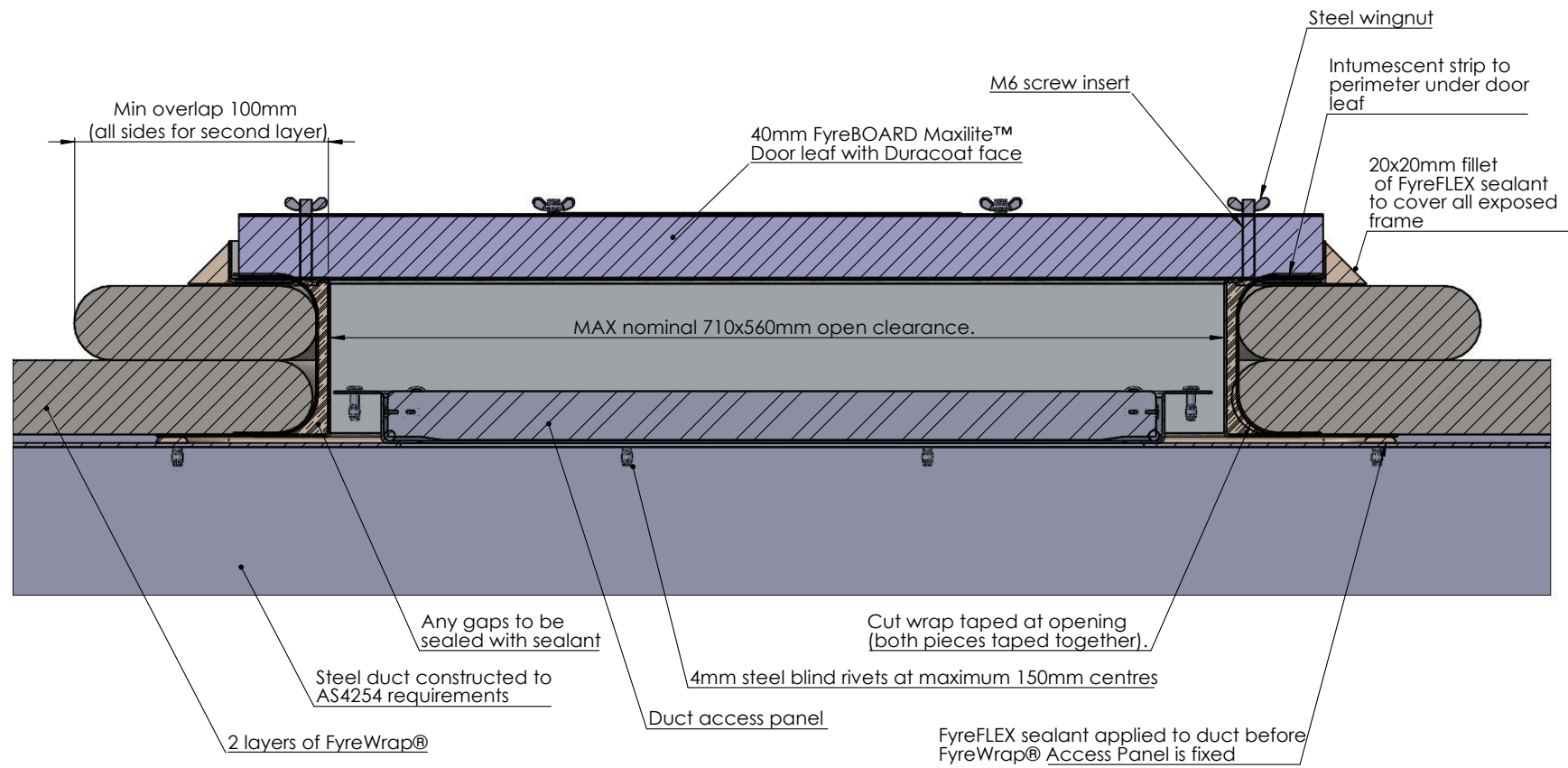

NOTE: Maximum FyreWrap® Access Panel size: Nominal 710x560mm open clearance

| | | | | | | | | | |
|---|---------------------------|----------------------------|---------------|--|--------------------------|---|--------------|-------------|---|
| Drawing Name: 2. FWAP MKII | | | | Test Standard: AS1530.4 - 2014 | Codes: | Revision: | Date: | No.: | NOTICE: |
| Project Title: FyreWrap® Install Details | | | | Fire resistance level: 120/120/120 | Drawn By: JH | | | | <small>NOTE: ALL DIMENSIONS ARE IN MILLIMETRES (mm)</small> |
| Drawing No. : 21 | Sheet: 21 of 26 | Date: 16/11/2016 | Scale: | Based on Report No.: FCO 3226 | Checked By: CT | <input type="checkbox"/> STANDARD DRAWING <input type="checkbox"/> PROJECT DRAWING | | | |

FWAP Fan Enclosure - Front View

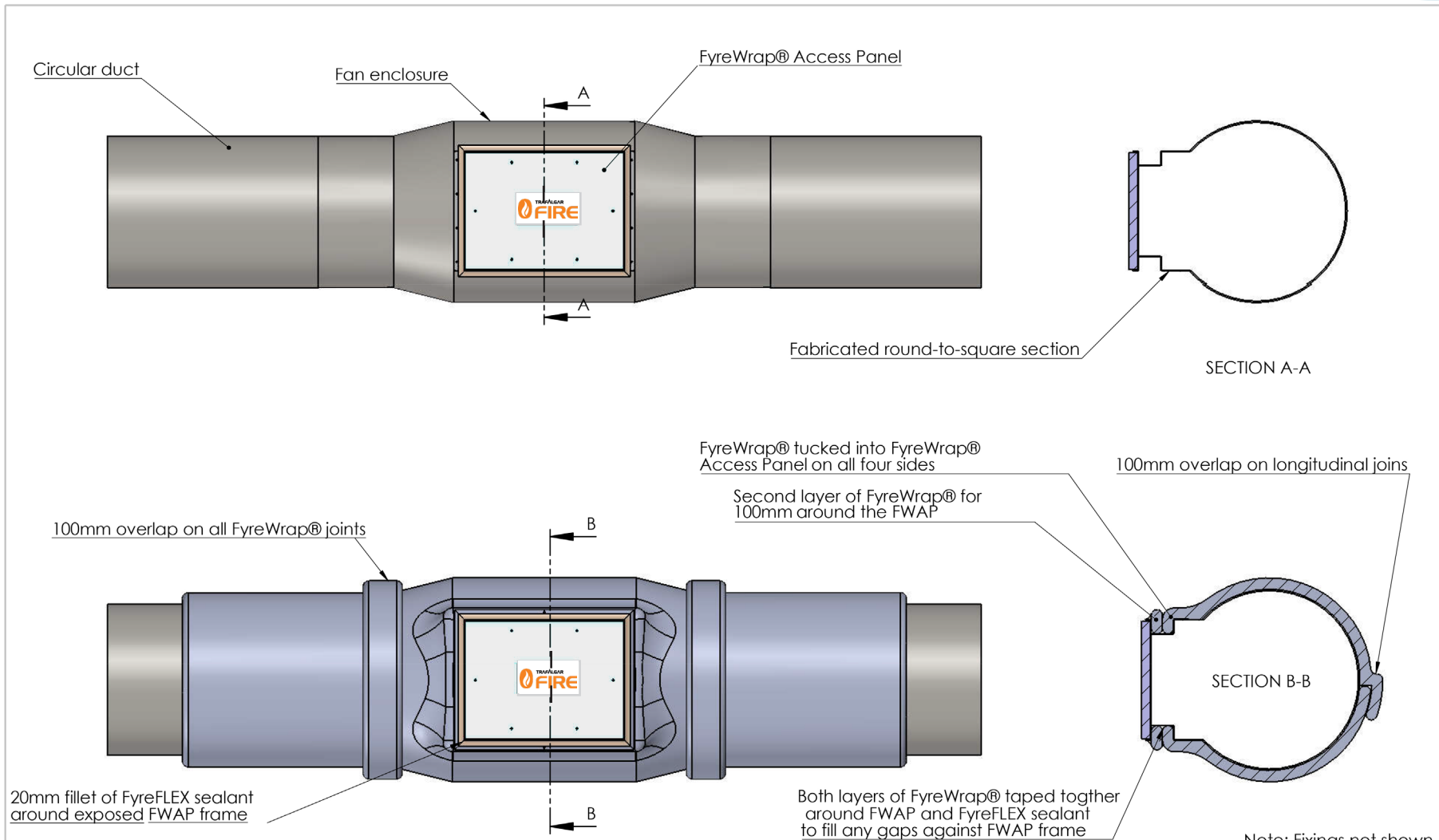

Note: Fixings not shown

| | | | | | | | | | |
|--|-------------------------|----------------------------|---------------|-----------------------------------|--------------------------|--|--|------------------|---|
| Drawing Name: FWAP - fan enclosure front view | | | | Test Standard: AS1530.4 | Codes: | Revision: Issued for Install | Date: 13/12/2016 | No.: 1 | NOTICE: |
| Project Title: FyreWrap® for fan enclosures | | | | Fire resistance level: | Drawn By: JH | | | | <small>NOTE: ALL DIMENSIONS ARE IN MILLIMETRES (MM)</small> |
| Drawing No. : 2 | Sheet: 2 of 2 | Date: 13/12/2016 | Scale: | Based on Report No.: | Checked By: CT | <input checked="" type="checkbox"/> STANDARD DRAWING | <input type="checkbox"/> PROJECT DRAWING | | |

FWAP Fan Enclosure - Side View

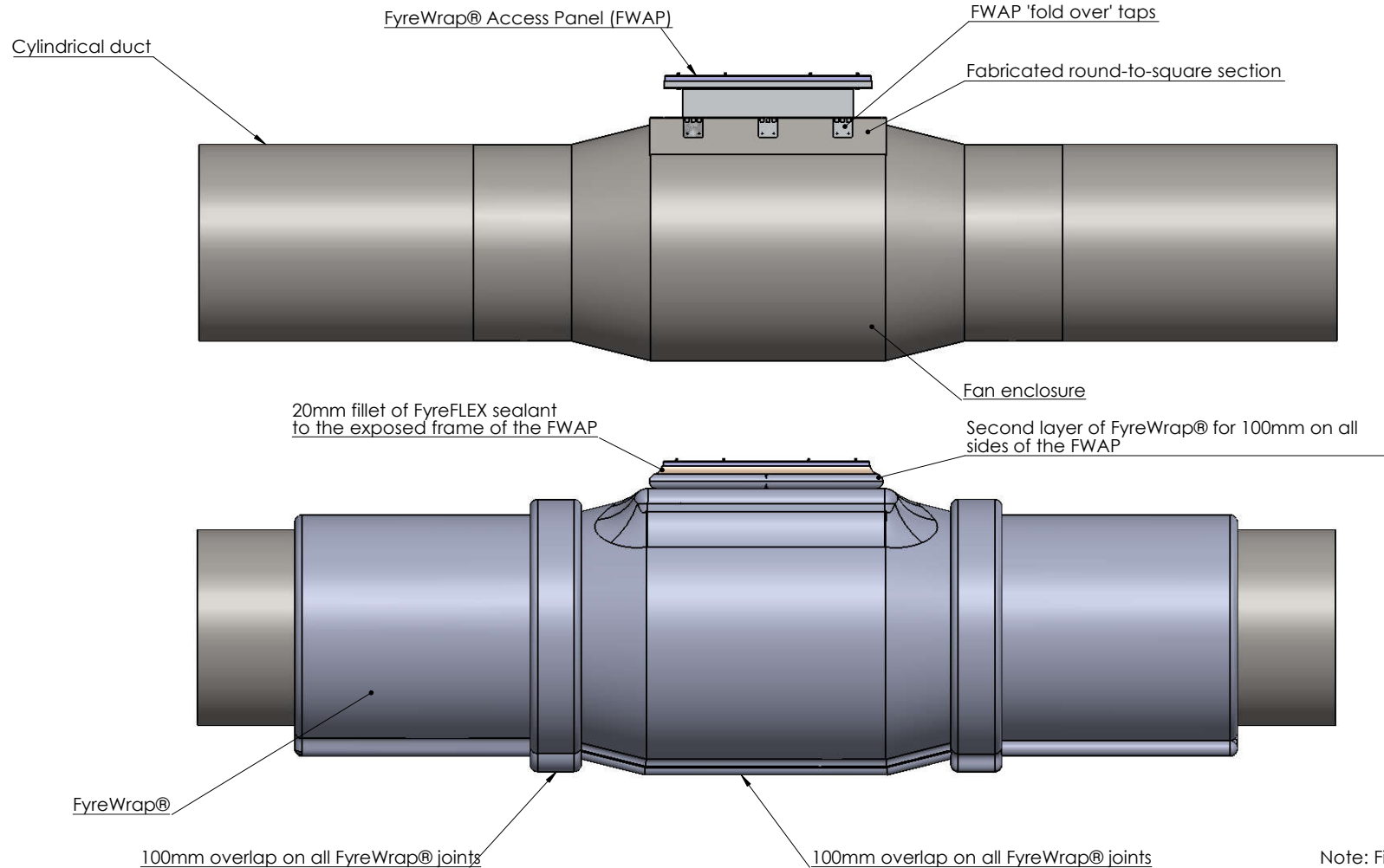

| | | | | | | | | | |
|---|-------------------------|----------------------------|---------------|-----------------------------------|--------------------------|--|----------------------------|------------------|----------------|
| Drawing Name: FWAP - fan enclosure side view | | | | Test Standard: AS1530.4 | Codes: | Revision: | Date: 13/12/2016 | No.: 1 | NOTICE: |
| Project Title: FyreWrap® for fan enclosures | | | | Fire resistance level: | Drawn By: JH | NOTE: ALL DIMENSIONS ARE IN MILLIMETRES (mm) | | | |
| Drawing No. : 1 | Sheet: 1 of 2 | Date: 13/12/2016 | Scale: | Based on Report No.: | Checked By: CT | <input checked="" type="checkbox"/> STANDARD DRAWING <input type="checkbox"/> PROJECT DRAWING | | | |

Out of Line Damper

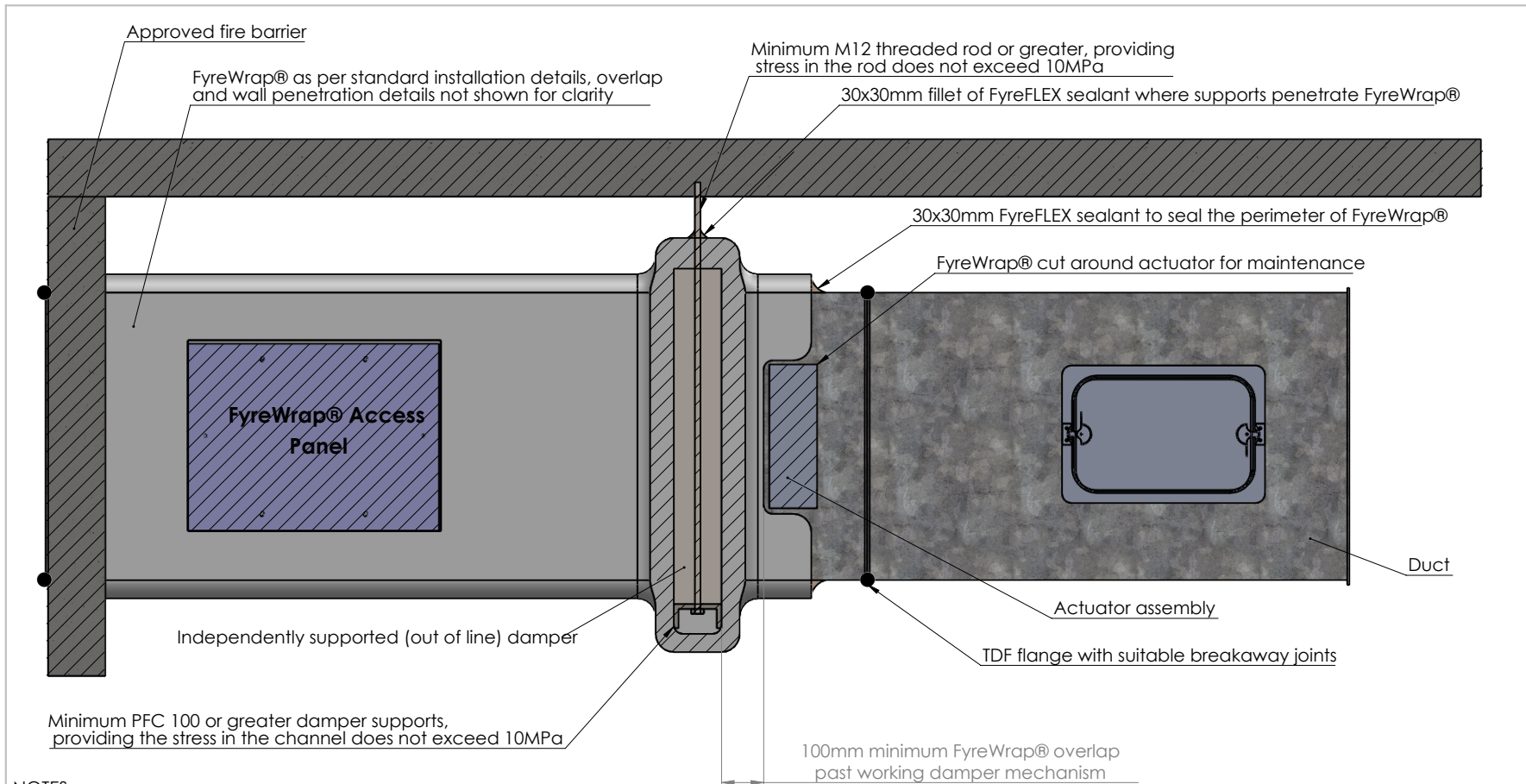

NOTES:

- FyreWrap® overlaps have not been shown for clarity
- Dampers to be installed to manufacturers instructions
- Damper fixings not shown for clarity
- Adequate fixings of FyreWrap® to be in conjunction with Trafalgar Fire's recommendation of maximum nominal duct size
- Threaded rod diameters and steel sections **MUST NOT** exceed the allowable stress limit of 10MPa in accordance with Trafalgar Fire's **BRANZ FAR 2567 report**
- indicates required location of break-away joints

| | | | | | | | | | |
|---|---------------|----------------------------|---------------|-----------------------------------|--------------------------|--|--------------|-------------|----------------|
| Drawing Name: Out of line damper install | | | | Test Standard: AS1530.4 | Codes: | Revision: | Date: | No.: | NOTICE: |
| Project Title: Out of line damper drawings | | | | Fire resistance level: | Drawn By: JH | NOTE: ALL DIMENSIONS ARE IN MILLIMETRES (mm) | | | |
| Drawing No. : | Sheet: | Date: 12/10/2020 | Scale: | Based on Report No.: | Checked By: CT | | | | |

