

TRAFALGAR CAST-IN PEX (CIPEX) CAST-IN FIRE COLLAR SYSTEMS



Trafalgar's Australian Made CIPEX Cast in fire collars are made specifically to tackle fire stopping for large PEX-AL-PEX pipes. Just like floor waste applications, Trafalgar has found that a mechanically assisted intumescent fire collar system is necessary to close these multi-layered pipes.



KEY FEATURES



- Robust and moisture resistant materials
- Simple install
- Tested to AS1530.4-2014 and AS4072.1

APPLICATIONS



- Cast into the slab during concrete pour
- Large Multi-Layer PEX-AL-PEX Pipes
- Water riser pipes up to 63mm

TRADES



TABLE OF CONTENTS



Section		Page
	Overview	1
	Compliance	3
FRL Tables	Fire Resistance Level	4
	Fire Test Approvals	5
	Installation Steps	6
	Upgrade Works	7
	System Range	8
	FAQ	9
	Technical Drawings	10

230123

COMPLIANCE

The National Construction Code (NCC) requires all service penetrations be treated in accordance with section C3.15, which in turn calls for the entire penetration system to be fire tested identically to how it is intended to be installed on the building site, in accordance with AS1530.4-2014. The key to this is that you are installing a system.

That comprises of:

- The floor slab thickness
- The type and size of the pipe
- The connecting fittings if present
- Installed in the same configuration (i.e. stack or floor waste).

The tested system must achieve or maintain the FRL of the floor slab (separating element) that it is installed into.

WHAT ARE PEX-AL-PEX PIPES?

With the price of copper increasing, alternative pipe materials are becoming more and more common for plumbing systems. Multi-layered pipes like PEX-AL-PEX are being developed in larger diameters to facilitate water and gas risers in modern building to take the place of the traditional copper pipes. These multi-layered pipes comprise of various layers of cross linked polyethylene with a sheath of Aluminium to provide high strength and pressure ratings required at larger diameters.

This presents an issue where new services are being introduced to the market with limited passive fire protection systems tested to maintain the FRL of the fire barriers that they penetrate through. Due to the aluminium layer which forms part of these multi-layer pipes, they are much harder to close during a fire and therefore need a mechanically assisted intumescent fire collar and also thermal insulation to deal with heat transfer.

WHAT ARE CIPEX COLLARS?

Trafalgar is proud to provide a compliant new Cast-In mechanically assisted fire collar developed and fire tested specifically for PEX-AL-PEX pipe materials. FRL ratings of up to -/120/120 have been achieved for fire rated concrete floor slabs for pipe sizes 40, 50 and 63mm.

Trafalgar is also currently finalizing a new range of patent pending mechanically assisted retrofittable fire collars for these pipe types – contact us for more information.

APPLICATIONS

- **40mm PEX-AL-PEX**
- **50mm PEX-AL-PEX**
- **63mm PEX-AL-PEX**

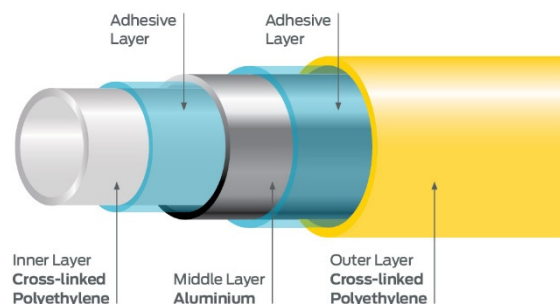

FIRE RESISTANCE LEVEL

FIRE RATING – HOW IS FIRE PERFORMANCE MEASURED?

An FRL (fire resistance level) is a handy way of summarising the performance of a building element. It consists of 3 numbers, all given in minutes:

FRL - /120/120

(example)



Structural Adequacy

The ability of the building element to support the weight of adjacent building elements.

ie: a brick wall supporting a concrete floor slab above.



Integrity

The ability of an element to prevent the passage of flames and hot gasses.

ie: a plasterboard wall remaining intact and not allowing holes to form.

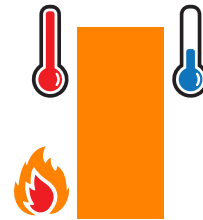

Insulation

The ability of an element to resist heat transfer from the exposed face to the unexposed face.

ie: a bundle of cables remaining below a set temperature limit on the unexposed side of the wall penetration system.

Penetrations are not required to have a Structural Adequacy rating and is usually expressed as a dash. For example, a penetration through a 2-hour load bearing wall would be written as -/120/120.

INTEGRITY

The CIPEX Collar system will achieve the integrity performance for up to 2 hours physically stopping the direct spread of fire, however the insulation performance of the penetration will be limited to concrete slab and conductivity of the services in the penetration.

INSULATION (TEMPERATURE RISE)

Heat transfer via conduction (or heat rise) is limited through cast-in collar systems. The concrete floor slab can absorb much of the heat, and plastic pipe services are usually not very thermally conductive however, due to the conductive Aluminium sheath inside the PEX-AL-PEX pipes, TWRAP™ must be used to achieve the full 2 hours of insulation performance. Refer to the tables below for specific details.

FIRE TEST APPROVALS

Service	Separating Element	Fire-Stopping System*	Maximum FRL	Test Report Reference
40mm PEX-AL-PEX pipe	Min 150mm thick concrete floor slab	Trafalgar CIPEX cast-in fire collar & TWrap 450	-/120/120	FAS 220119
50mm PEX-AL-PEX Pipe			-/120/120	FAS 220119
63mm PEX-AL-PEX Pipe	Min 175mm thick concrete floor slab	Trafalgar CIPEX cast-in fire collar & TWrap 600	-/120/120	FAS 220119

*TWrap is applied to the top side of the floor only.

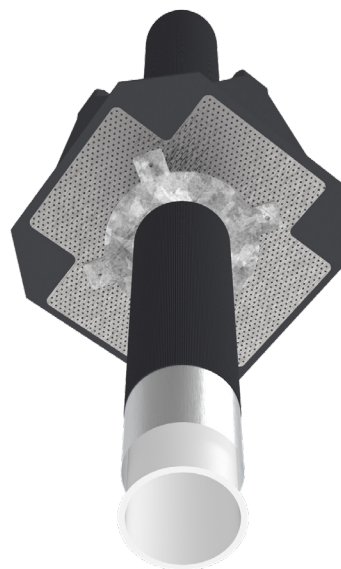
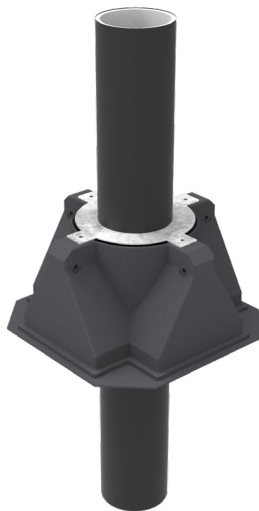

INSTALLATION

STEP 1 INSTALL COLLAR AND SECTION OF PIPE ONTO FORMWORK

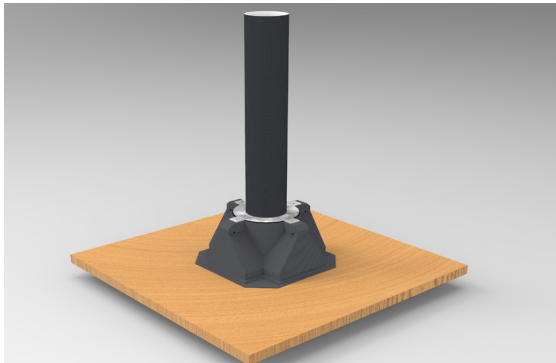

Select the correct size CIPEX Cast-in collar. The collar is nailed to the formwork, with a section of PEX-AL-PEX pipe installed through the collar extending above the planned slab level to form the penetration.

STEP 2 POUR CONCRETE & REMOVE FORMWORK



When the slab is poured and cured, remove the formwork.

STEP 3 CONNECT PIPES & SEAL



Knock the pipe down through the collar and connect the intended pipe.

STEP 4 INSTALL TWRAP



TWRap is wrapped around the service, to the approved length, secured with 4.6mm steel ties, 50mm from each end and 150mm centres in between.

UPGRADE WORKS

It is common on site to come across services that are not approved for the collar, the wrong size for the collar, or redundant collars that don't have any service running through it. Naturally in these scenarios, the FRL of the floor slab still needs to be maintained. Trafalgar Fire have a range of solutions for these instances.

1 - REDUNDANT COLLAR

For redundant collars, simply fix [FyreBOARD Maxilite®](#) to either the top or bottom side of the slab to the below specification. This method works for any size or brand of collar, as the FyreBOARD Maxilite® board blanks off the opening.

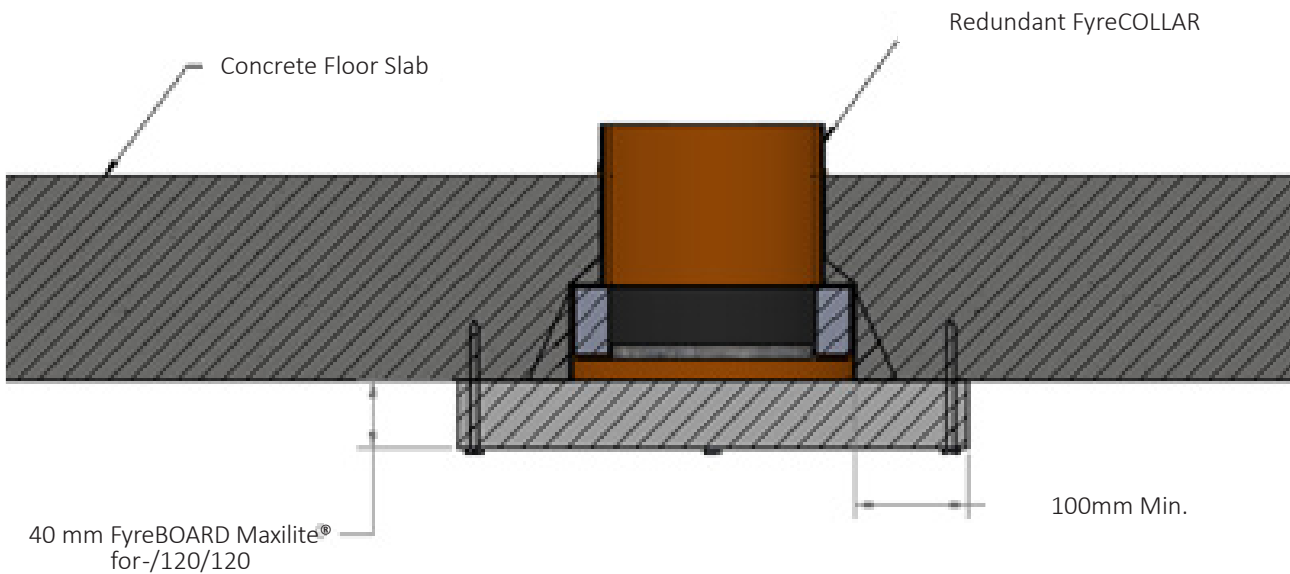

2 - WRONG SERVICE

Where a non-compliant service is installed into a cast-in fire collar, a retro-fit solution must now be put in place to maintain the FRL of the barrier. Refer to the below table for a summary of retrofit solutions for common services.

Non-Compliant Service	Retro-fit Fire Stopping	Reference
Electrical Cable Bundle	60mm FyreBOARD Maxilite® to the top side of the slab, FyreFLEX® sealant and TWRAP™	FyreFLEX® Sealant Technical Manual for Electricians
Copper or Steel Pipe	60mm FyreBOARD Maxilite® on the top side, FyreFLEX® sealant and TWRAP™	FyreFLEX® Sealant Technical Manual for Plumbers

For any other service types, contact technical@tgroup.com.au for the best way to fire rate the penetration.

SYSTEM RANGE

Fyre COLLAR CAST-IN PEX



Item Number	Description	Min Order Qty
FyreCOLLAR-CIPEX-40	Cast in Fire collar to suit 40mm PEX Pipe	1
FyreCOLLAR-CIPEX-50	Cast in Fire collar to suit 50mm PEX Pipe	1
FyreCOLLAR-CIPEX-63	Cast in Fire collar to suit 63mm PEX Pipe	1

TWRAP



SYSTEM COMPONENTS

Item Number	Description	Min Order Qty	Pallet QTY
TWRAP 300	300mm wide, 25mm thick blanket	7620mm long roll	24
TWRAP 450	450mm wide, 25mm thick blanket	7620mm long roll	24
TWRAP 600	600mm wide, 25mm thick blanket	7620mm long roll	24

FAQ

Q Can I backfill a redundant (unused) FyreCOLLAR Cast-In with concrete to maintain the FRL?

A No, this runs the risk of the collar plastic melting in a fire and the back-filled concrete slipping out. [FyreBOARD Maxilite®](#) can be used, refer to [page 5](#).

Q Can I use a bigger collar for a smaller pipe?

A The pipe must be the correct size per the approvals tables in this manual.

Q How far apart do the cast-in collars have to be? Can I overlap the flanges?

A The collars should be at least 200mm apart.

SOCIAL MEDIA



Linked 

 YouTube

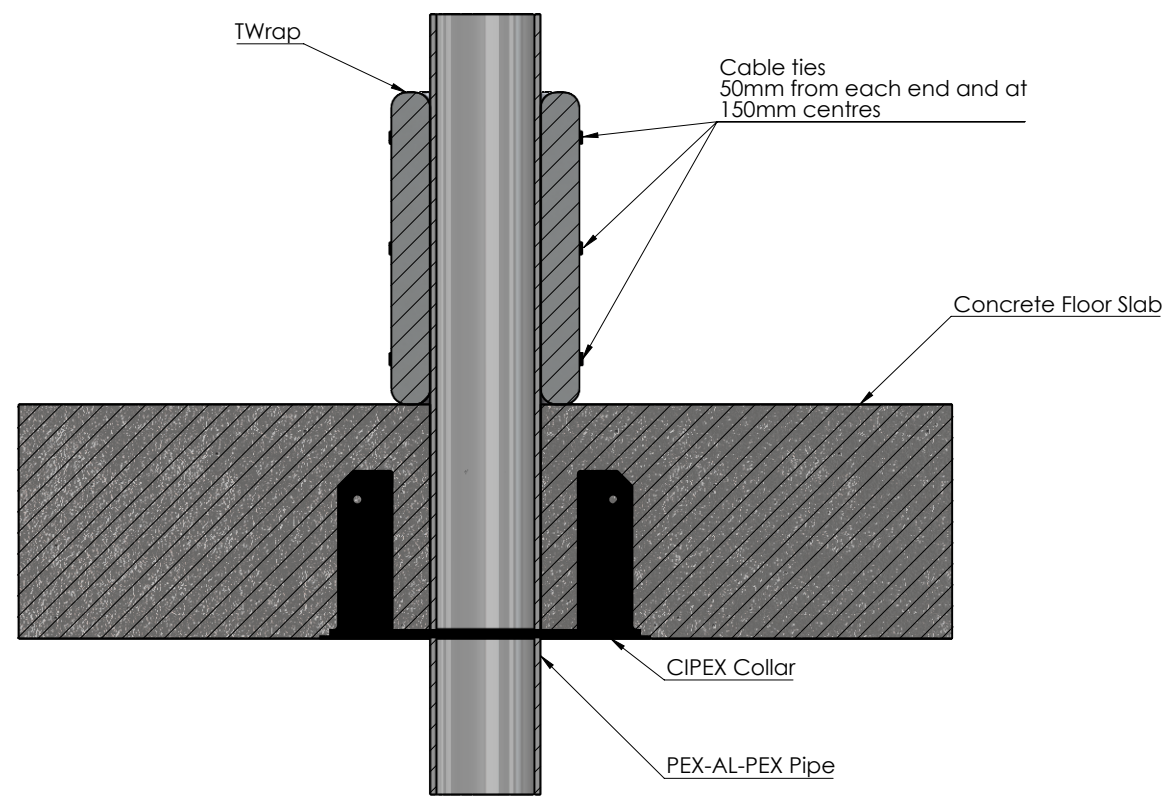

Drawing Name: Overview				Test Standard: AS1530.4	Codes:	Revision:	Date:	No.:	NOTICE:
Project Title: CIPEX Fire Collar				Fire resistance level:	Drawn By: SM	<small>NOTE: ALL DIMENSIONS ARE IN MILLIMETRES (mm)</small>			
Drawing No. : 1	Sheet: 1 of 1	Date: 1/18/2023	Scale: NTS	Based on Report No.:	Checked By: JH	<input type="checkbox"/> STANDARD DRAWING	 <p>TRAFALGAR FIRE PO BOX 545 Chester Hill NSW 2162 T: 1800 888 714 F: 1800 201 500 E: technical@tgroup.com.au W: www.fire.com.au</p>		
						<input type="checkbox"/> PROJECT DRAWING			

230123