

Penetration seal

PROMASEAL[®]-FC Collars

Fire resistant collar for plastic pipes penetration seals

Installation guide

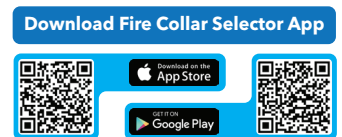

www.promat.com



PROMASEAL®-FC Collars Installation Instructions

PROMASEAL®-FC collars are multi-purpose collars designed for use with concrete slabs, masonry, Speedpanel and lightweight walls and Promat SYSTEMFLOOR™-FR ceilings. The collars can be split to enable them to be retrofitted or relocated when necessary. They are available in a range of sizes to suit plastic pipes up to 315mm outside diameter. The collars have been tested for up to -/240/240 fire resistance in accordance with the criteria of AS 1530: Part 4: 2014 and AS 4072: Part 1: 2005 with various types and sizes of plastic pipe. Collars at and above 250mm diameter have a circular base, not square.

Code no.	Pipe nominal diameter	Body			Flange
		H	D1	D2	D3
FC 40	40mm	43mm	45mm	77mm	112mm
FC 50	50mm	43mm	58mm	90mm	125mm
FC 65	65mm	43mm	71mm	103mm	138mm
FC 80	80mm	43mm	85mm	123mm	158mm
FC 100	100mm	53mm	112mm	150mm	185mm
FC 150	150mm	73mm	162mm	200mm	235mm
FC 250	250mm	120mm	254mm	316mm	380mm Ø
FC 300	300mm	160mm	318mm	402mm	466mm Ø

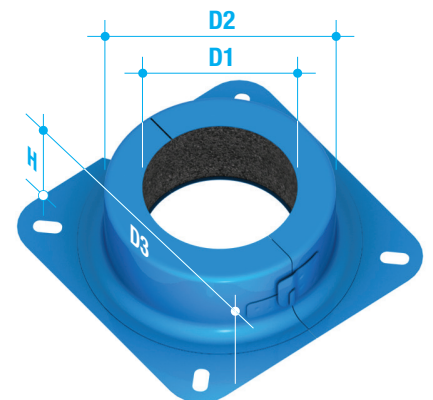

Table 1 - uPVC pipes protected with PROMASEAL®-FC collars in floors

Pipe Material	Outside Diameter (OD) (mm)	Pipe Wall Thickness (mm)	FC Collar Code	FRL		
				120mm Slab	150mm Slab	170mm Slab
uPVC	43	2.6	FC40	-/240/180	-/240/180	-/240/240
	56	2.2-3	FC50	-/240/180	-/240/180	-/240/240
	69	2.8	FC65	-/240/240	-/240/240	-/240/240
	83	3.4	FC80	-/240/240	-/240/240	-/240/240
	110	3.4	FC100	-/240/240	-/240/240	-/240/240
	161	5	FC150	-/240/120	-/240/120	-/240/120
	225	6.6	FC250	-/240/120	-/240/180	-/240/240
	251	6	FC250	-/240/120	-/240/240	-/240/240
	315	10	FC300	-/180/120	-/180/180	-/180/180

Table 2 - HDPE pipes protected with PROMASEAL®-FC collars in floors

Pipe Material	Outside Diameter (OD) (mm)	Pipe Wall Thickness (mm)	FC Collar Code	FRL		
				120mm Slab	150mm Slab	170mm Slab
HDPE	40.6	2.6	FC40	-/240/120	-/240/180	-/240/240
	56	2.2-3	FC50	-/180/120	-/180/180	-/180/180
	63.5	3.3	FC65	-/240/120	-/240/180	-/240/240
	75	3	FC80	-/240/120	-/240/180	-/240/240
	110	3.4-5.88	FC100	-/240/120	-/240/180	-/240/240
	125	3.4	FC125	-/240/120	-/240/180	-/240/240
	150	5	FC150	-/180/120	-/180/180	-/180/180
	254	10	FC250	-/240/120	-/240/180	-/240/240
	320	10	FC300	-	-	-/120/120

Table 3 - uPVC pipes protected with PROMASEAL®-FC collars in 128mm Walls

Pipe Material	Outside Diameter (OD) (mm)	Pipe Wall Thickness (mm)	FC Collar Code	FRL
uPVC	43	2.4	FC40	-/240/180
	56	2.2	FC50	-/120/120
	69	3.2	FC65	-/180/180
	83	3	FC80	-/120/120
	110	4.3	FC100	-/120/120
	161	4.56	FC150	-/180/120
	251	6.56	FC250	-/180/180
	315	8.2	FC300	-/180/180

Table 4 - HDPE pipes protected with PROMASEAL®-FC collars in 128mm Walls

Pipe Material	Outside Diameter (OD) (mm)	Pipe Wall Thickness (mm)	FC Collar Code	FRL
HDPE	40.6	3.15	FC40	-/180/180
	63.5	3.3	FC65	-/120/120
	75	4	FC80	-/120/120
	110	5	FC100	-/180/120
	125	6	FC150	-/120/120
	252	8	FC250	-/120/120
	317	13.5	FC300	-/180/180

Table 5 - uPVC pipes protected with PROMASEAL®-FC collars in 116mm Walls

Pipe Material	Outside Diameter (OD) (mm)	Pipe Wall Thickness (mm)	FC Collar Code	FRL
uPVC	43	2.4	FC40	-/120/120
	56	2.2	FC50	-/120/120
	69	3.2	FC65	-/120/120
	83	3	FC80	-/120/120
	110	4.3	FC100	-/120/120
	251	6.56	FC250	-/120/120
	315	8.2	FC300	-/120/120

Table 6 - HDPE pipes protected with PROMASEAL®-FC collars in 116mm Walls

Pipe Material	Outside Diameter (OD) (mm)	Pipe Wall Thickness (mm)	FC Collar Code	FRL
HDPE	40.6	3.15	FC40	-/120/120
	63.5	3.3	FC65	-/120/120
	75	4	FC80	-/120/120
	110	5	FC100	-/120/120

Table 7 - uPVC pipes protected with PROMASEAL®-FC collars in 78mm Speedpanel Walls*

Pipe Material	Outside Diameter (OD) (mm)	Pipe Wall Thickness (mm)	FC Collar Code	FRL
uPVC	43	2.4	FC40	-/120/120
	56	2.2	FC50	-/120/120
	69	3.2	FC65	-/120/120
	83	3	FC80	-/120/120
	110	4.3	FC100	-/120/120
	158	4.3	FC150	-/120/120

* Thickened with Min. 25mm PROMATECT® - 100 boards

Table 8 - HDPE pipes protected with PROMASEAL®-FC collars in 78mm Speedpanel Walls*

Pipe Material	Outside Diameter (OD) (mm)	Pipe Wall Thickness (mm)	FC Collar Code	FRL
HDPE	40.6	3.15	FC40	-/120/120
	55.7	3.4	FC50	-/120/120
	63.5	3.3	FC65	-/120/120
	110	5	FC100	-/120/120

* Thickened with Min. 25mm PROMATECT® - 100 boards

Table 9 - Coestilin HDPE pipes protected with PROMASEAL®-FC collars in 78mm Speedpanel Walls*

Pipe Material	Outside Diameter (OD) (mm)	Pipe Wall Thickness (mm)	FC Collar Code	FRL
Coestilin HDPE	56	3	FC65	-/120/120
	75	4	FC80	-/120/120
	110	5	FC100	-/120/120
	125	6	FC150	-/120/120
	160	7.5	FC150	-/120/120
	200	7	FC250	-/120/120
	250	8	FC250	-/120/120

* Thickened with Min. 25mm PROMATECT® - 100 boards

Table 10 - uPVC pipes protected with PROMASEAL®-FC collars in 94mm PROMATECT®-100 Walls (1 x 15mm each face)

Pipe Material	Outside Diameter (OD) (mm)	Pipe Wall Thickness (mm)	FC Collar Code	FRL
uPVC	43.6	2.4	FC40	-/90/90
	55.7	2.2	FC50	-/90/60
	69.4	3.2	FC65	-/90/60
	82.5	3	FC80	-/90/60
	110	3.4	FC100	-/90/60

Table 11 - uPVC pipes protected with PROMASEAL®-FC collars in 90mm FR Plasterboard Walls (1 x 13mm each face)

Pipe Material	Outside Diameter (OD) (mm)	Pipe Wall Thickness (mm)	FC Collar Code	FRL
uPVC	43.6	2.4	FC40	-/60/60
	55.7	2.2	FC50	-/60/45
	69.4	3.2	FC65	-/60/45
	82.5	3	FC80	-/60/45
	110	3.7	FC100	-/60/45

Table 12 - uPVC pipes protected with PROMASEAL®-FC collars in 266mm Promat SYSTEMFLOOR™-FR Floor/Ceiling

Pipe Material	Outside Diameter (OD) (mm)	Pipe Wall Thickness (mm)	FC Collar Code	FRL
uPVC	42.5	3.61	FC40	-/120/120
	55.7	2.2	FC50	-/120/120
	69.4	3.2	FC65	-/120/120
	82.5	3	FC80	-/120/120
	110	3.8	FC100	-/120/120

Table 13 - uPVC pipes protected with PROMASEAL®-FC collars in 100mm PROMASEAL® Bulkhead Batts (Slab Opening)

Pipe Material	Outside Diameter (OD) (mm)	Pipe Wall Thickness (mm)	FC Collar Code	FRL
uPVC	43.21	3.2	FC40	-/120/120
	55.7	3.11	FC50	-/120/120
	67.7	3.2	FC65	-/120/120
	82.5	3	FC80	-/120/120
	110	3.8	FC100	-/120/120

Table 14 - HDPE pipes protected with PROMASEAL®-FC collars in 100mm PROMASEAL® Bulkhead Batts (Slab Opening)

Pipe Material	Outside Diameter (OD) (mm)	Pipe Wall Thickness (mm)	FC Collar Code	FRL
HDPE	40.46	2.93	FC40	-/120/120
	56	2.2-3.0	FC50	-/120/120
	63.5	3.3	FC65	-/120/120
	75	3.0	FC80	-/120/120
	110	3.4-5.88	FC100	-/120/120
	125	3.4	FC125	-/120/120
	150	5.0	FC150	-/120/120

Installation method

For pipes up to 315mm outside diameter to the underside of concrete floor slabs

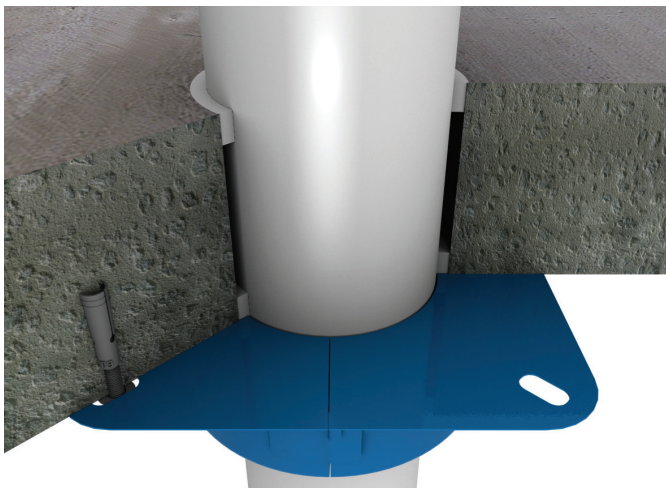

PROMASEAL®-FC collars are to be fixed to the under side of the floor slabs. Ensure all fixing points are used. Diameter of pipes can be up to 315mm.

For up to -/240/240 fire resistance application with pipes up to 225mm outside diameter, the collars are bolted to the soffit of a floor slab using 38mm steel expanding anchors or steel wedge anchors. Fixings for collars up to 162mm diameter may be 25mm steel sleeve anchors. Certain pipes with 315mm outside diameter can achieve up to -/120/120 fire resistance in this application.

If there is a possibility of pipe movement occurring that will cause cracks or fissures in the seal between the pipe and mortar mix, it is advisable to seal around the pipe with PROMASEAL®-A Acrylic Sealant to prevent cold smoke leakage. This, however is not required for the fire resistance to be achieved.

If there is a gap greater than 12mm between the pipe and cored hole, backfill with PROMASEAL® Mortar. For gaps less than 12mm, seal with PROMASEAL®-A Acrylic Sealant.

For uPVC pipes up to 110mm outside diameter on walls

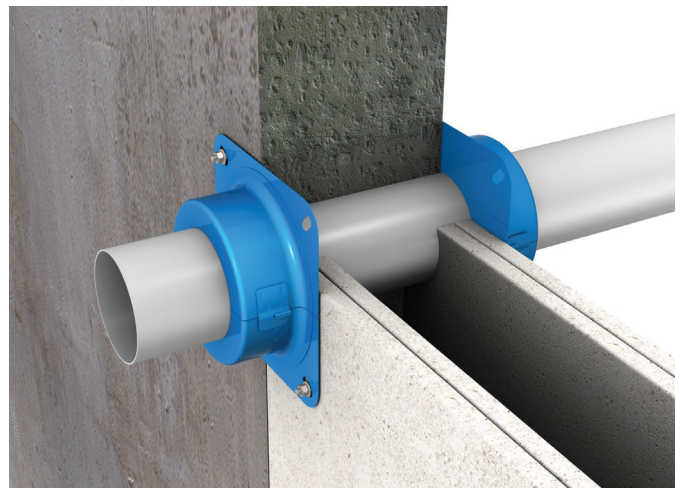

For -/120/120 fire resistant masonry or lightweight walls application for uPVC pipes up to 110mm* outside diameter.

For application on masonry and double layer fire resistant plasterboard walls for pipes up to 110mm outside diameter. Minimum wall thickness is 116mm. The collars must be on both faces for lightweight timber or steel framed walls with 4 x 6g x 40mm long coarse thread screws. For collars above 150mm outside diameter in walls, 8mm diameter threaded rods must pass from one side of the wall to the other and nuts placed onto the ends of the bolts where they pass through the fixing points of the collar.

* For Fire Resistant Plasterboard consisting of single layer on each face and PROMATECT®-100 walls consisting of a single layer of 15mm on each face. Collars are approved for 40 to 100mm uPVC for an FRL of -/60/60. Collar fixed to both faces of the wall with 6g x 40mm long coarse thread screws.

For pipes up to 250mm in Speedpanel Walls

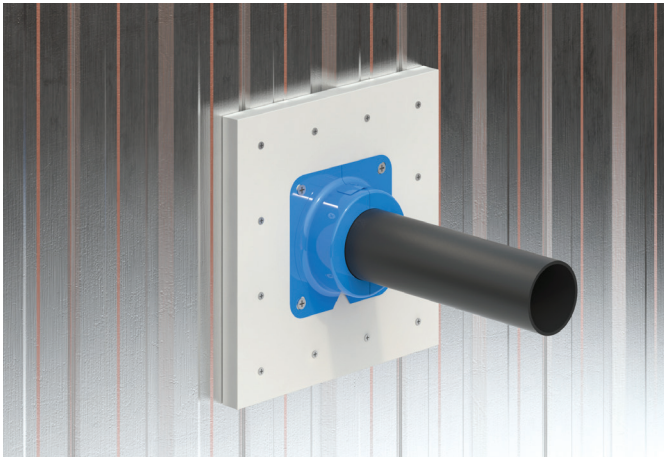

PROMASEAL®-FC collars can be installed on 78mm thick Speedpanel walls with upvc pipes up to 160mm OD and 250mm OD for HDPE. Before the collar is installed a layer of 25mm PROMATECT®-100 or 250 with a size that is 2 x the flange length of the collar. i.e. for a 100mm pipe the board is 370mm x 370mm. The board is fixed to the Speedpanel at 100mm centres with 10g x 40mm coarse thread bugle head screws. Any board joints are sealed with PROMASEAL®-A Acrylic Sealant. The collars are then fixed to each side of the board cladding with 40mm long coarse thread screws. Multiple pipes through one opening are allowed up to an opening size of 600mm wide x 11300mm high. FRL -/120/120.

For pipes up to 150mm through PROMASEAL® Bulkhead Batt in 120mm slabs

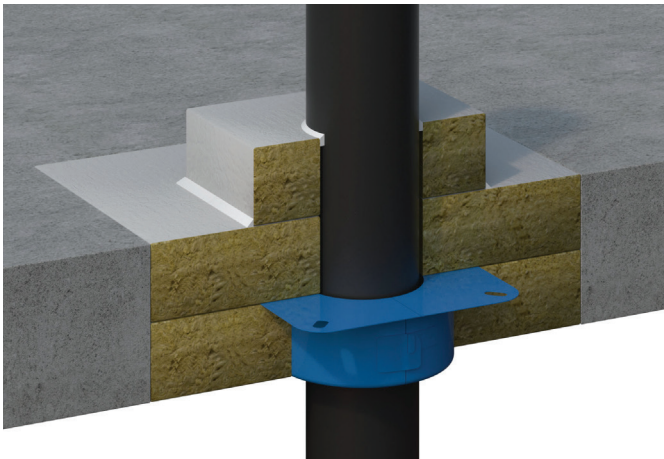

PROMASEAL®-FC collars can be installed within the bottom layer of PROMASEAL® Bulkhead Batts that are installed into a slab opening. 2 x 50mm layers of the PROMASEAL® Bulkhead batts are installed either with two on top of the opening, overlapping by 50mm all round or with both batts friction fit within the slab opening. The collar is installed within the bottom layer with the flange in the interface between the two layers. On the top side a third layer of batt 120mm x 120mm for 40mm pipes and 190 x 190mm for all other sizes is installed locally to the pipe. The gap between batt and pipe is sealed with PROMASEAL®-A Acrylic Sealant. For uPVC pipes the approved sizes are from 40 to 100mm. For HDPE pipes the approved sizes are 40-150mm. The FRL achieved is -/120/120 for all pipe types and sizes.

For uPVC pipes up to 110mm OD under SYSTEMFLOOR™-FR Floor /Ceiling System

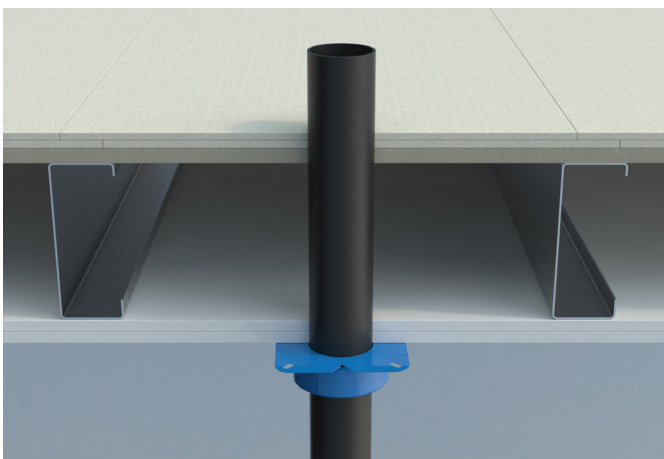

PROMASEAL®-FC collars can be installed around uPVC pipes penetrating the Promat SYSTEMFLOOR™-FR Floor Ceiling System. Before the collar is installed the annular gap between the pipe and ceiling is filled with PROMASEAL®-A Acrylic Sealant. The Collars are then installed to the ceiling side with 32mm long plasterboard laminating screws. The gap between the pipe and floor is required to be sealed with PROMASEAL®-A. For uPVC the approved sizes are 40 -100mm and the FRL achieved is -/120/120.

Contact Promat for further installation methods for ceilings and services other than plastic pipes.

Promat

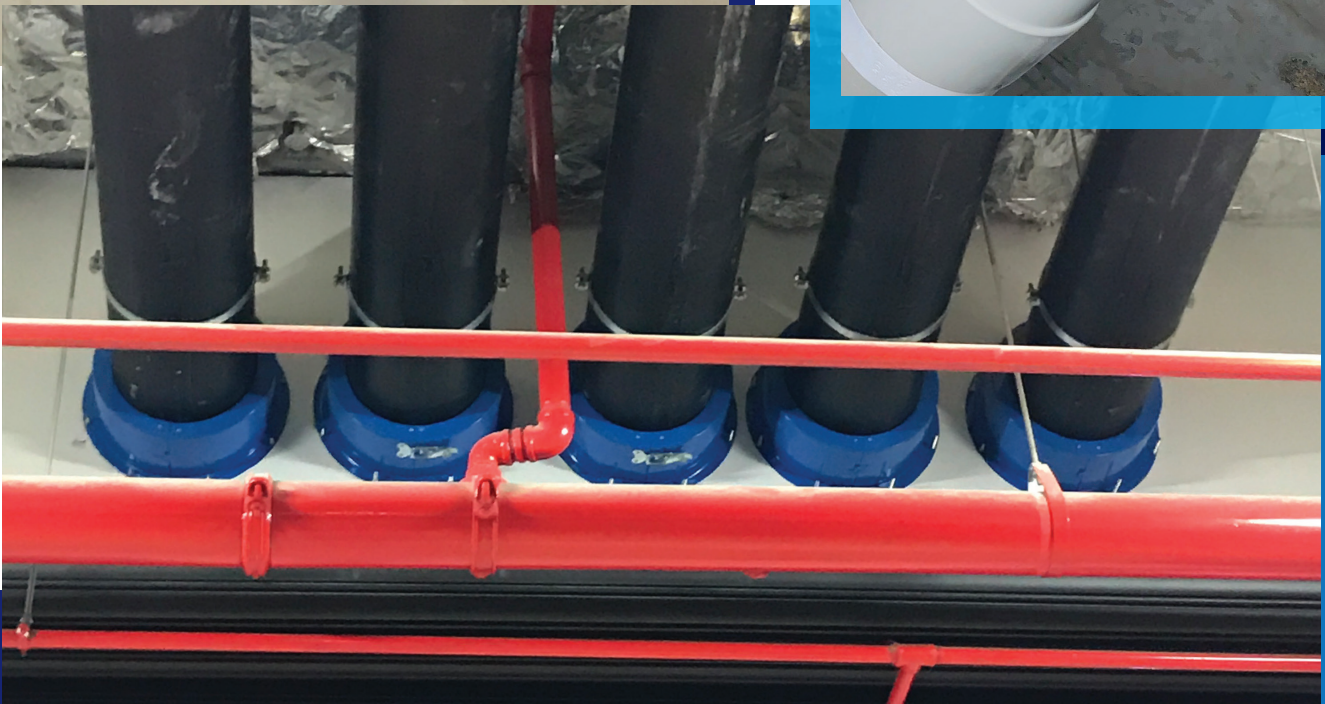

Promat

Australia

Promat Australia Pty Ltd

South Australia office

1 Scotland Road
SA 5031 Mile End South
☎ 1800 Promat (776 628)
☎ +61 8 8352 1014
✉ PAPT.mail@etexgroup.com

New South Wales office

Unit 1, 175 Briens Road
Northmead, NSW 2152
☎ 1800 Promat (776 628)
☎ +61 2 9630 0258
✉ PAPT.mail@etexgroup.com

Victoria office

Unit 1, 355 Grieve Parade
Altona North, VIC 3025
☎ 1800 Promat (776 628)
☎ 1800 334 598
✉ PAPT.mail@etexgroup.com

Queensland office

80 Stradbroke St
Heathwood QLD 4110
☎ 1800 011 376
☎ 1800 334 598
✉ PAPT.mail@etexgroup.com

China

Promat Shanghai Ltd

No.2, Tai Hua Street
Yonghe Economic District
Guangzhou City
Guangdong Province 511356
☎ +86 20 8136 1167
✉ promat.cn@etexgroup.com

Hong Kong

Promat International (Asia Pacific) Ltd

Room 1010, C.C. Wu Building
302-308 Hennessy Road
Wanchai
☎ +852 2836 3692
✉ promat.hk@etexgroup.com

Malaysia

Etex Malaysia Sdn Bhd

(Formerly known as Promat (Malaysia) Sdn. Bhd.)
Unit 19-02-01, Level 2, Wisma Tune
19 Lorong Dungun, Damansara Heights
50490 Kuala Lumpur
☎ +60 3 2095 8555
✉ promat.my@etexgroup.com

Singapore

Promat Building System Pte Ltd

10 Science Park Road, #03-14 The Alpha
Singapore Science Park II
117684 Singapore
☎ +65 6776 7635
✉ promat.sg@etexgroup.com

www.promat.com

- The technical data provided in this publication is based on mean values prevalent at time of publication and is thus subject to fluctuation. It should not be regarded as a guarantee to system performance.
- All data contained herein conforms to and frequently surpasses generally accepted fire protection standards recognised by most professional fire science practitioners and regulatory authorities worldwide. The same general principle is equally applicable to all Promat products and systems. Promat has access to a considerable body of test authentication data and this can be provided on a complimentary basis upon request. It should be noted however that this publication replaces all previous editions in its entirety.
- This document is protected by International copyright laws. Reproduction and distribution in whole or in part without prior written permission is strictly prohibited. PROMAT, PROMATECT, PROMASEAL and logo are registered trademark of Etex NV or an affiliate thereof in Asia Pacific and/or other countries. Any use without authorisation is prohibited and may violate trademark laws.

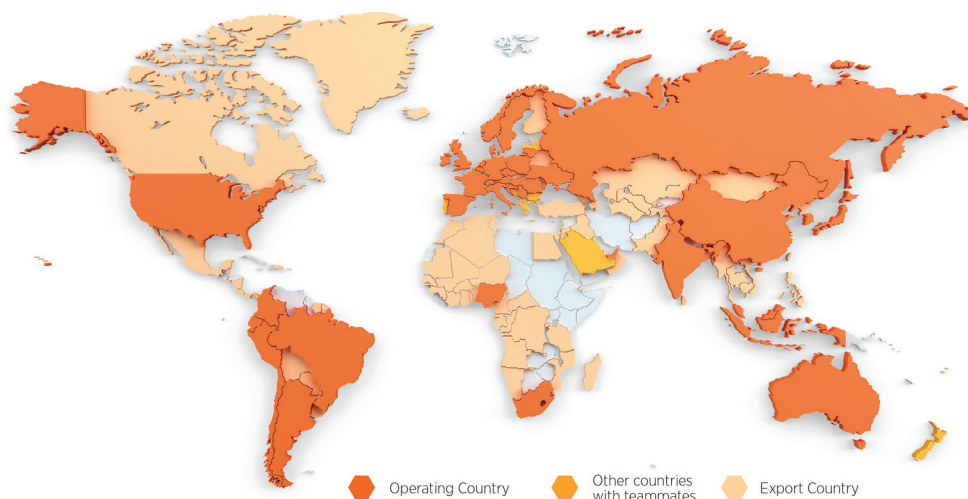

About Etex

Etex is an international building materials specialist; the company wants to inspire people around the world to build living spaces that are ever more safe, sustainable, smart and beautiful. Founded since 1905 and headquartered in Belgium, Etex currently operates more than 140 sites including plants, quarries and offices in 45 countries with over 13,500 employees globally.

Etex fosters a collaborative and caring culture, a pioneering spirit and a passion to always do better for its customers. Building on its experience and global market needs, the company strives to improve its customers quality of living with ever more effective lightweight solutions.

Its three R&D centres support four global sales divisions:

- Building Performance: Leader in plasterboards and fibre cement boards, and the global reference in passive fire protection solutions for the residential and commercial segments.
- Exteriors: Provider of innovative, durable, high performance and beautiful fibre cement exterior materials for architectural, residential and agricultural projects.
- Industry: Front runner of engineering expertise to drive the future of high performance thermal and acoustic insulation as well as passive fire protection in the industrial, aerospace and energy sectors.
- New Ways: New Ways offers high-tech, lightweight, factory-assembled panel and modular solutions based on timber and steel framing.

Etex is Inspiring Ways of Living, for more information, please visit our website: www.etexgroup.com