



Fire assessment report

Fire resistance performance of uPVC and HDPE pipe penetration protected with Promaseal FCW fire collars

Client: Promat Australia Pty Ltd

Report number: C91513 Reference number: FAS190366 Revision: R4.4

Issue date: 12 September 2022 Expiry date: 28 February 2025

Amendment schedule

Version	Date	Information relating to report			
R1.0	Issue: 26/07/1999	Reason for issue	Initial issue.		
			Prepared by	Reviewed by	Approved by
	Expiry: 15/07/2001	Name	Paul England	David Baker	–
R2.0	Issue: 17/09/2004	Reason for issue	Review report WFRA 45761.1 issued to extend validity to for years.		
			Prepared by	Reviewed by	Approved by
	Expiry: 30/09/2009	Name	K. W. Chan	J. P. England	–
R3.0	Issue: 30/03/2015	Reason for issue	Review report EWFA 34558300c issued to extend validity to for years.		
			Prepared by	Reviewed by	Approved by
	Expiry: 31/03/2020	Name	D. Nicholson	K. G. Nicholls	–
R4.0	Issue: 29/01/2020	Reason for issue	Report revalidated in accordance with AS 1513.4:2014 and AS 4072.1-2005 and updated to include additional variations.		
			Prepared by	Reviewed by	Approved by
	Expiry: 28/02/2025	Name	Sina Soylu	Omar Saad	Omar Saad
		Signature	–	–	–
R4.1	Issue: 31/01/2020	Reason for issue	Report updated to reflect client's comments.		
			Prepared by	Reviewed by	Approved by
	Expiry: 28/02/2025	Name	Sina Soylu	Omar Saad	Omar Saad
		Signature			
R4.2	Issue: 04/02/2020	Reason for issue	Report revised for a typo.		
			Prepared by	Reviewed by	Approved by
	Expiry: 28/02/2025	Name	Sina Soylu	Omar Saad	Omar Saad
		Signature			
R4.3	Issue: 21/06/2022	Reason for issue	Report updated to include additional substrates and		
			Prepared by	Reviewed by	Approved by
	Expiry: 28/02/2025	Name	Tanmay Bhat	Omar Saad	Omar Saad
R4.4	Issue: 12/09/2022	Reason for issue	Revised with the inclusion of additional figure		
			Prepared by	Reviewed by	Approved by
	Expiry: 28/02/2025	Name	Alim Rasel	Omar Saad	Omar Saad
		Signature			

Contact information

Warringtonfire Australia Pty Ltd – ABN 81 050 241 524

Melbourne – NATA registered laboratory

Unit 2, 409-411 Hammond Road
Dandenong South, VIC 3175
Australia

T: +61 3 9767 1000

Sydney

Suite 802, Level 8
383 Kent Street
Sydney, NSW 2000
Australia

T: +61 2 9211 4333

Brisbane

Suite 6, Level 12
133 Mary Street
Brisbane, QLD 4000
Australia

T: +61 7 3238 1700

General conditions of use

This report may only be reproduced in full without modifications by the report sponsor. Copies, extracts or abridgments of this report in any form must not be published by other organisations or individuals without the permission of Warringtonfire Australia.

Warringtonfire Australia is not able to discuss the contents of this report with third parties without the consent of the report sponsor(s).

All work and services carried out by Warringtonfire Australia are subject to and conducted in accordance with our standard terms and conditions. These are available at <https://www.element.com/terms/terms-and-conditions> or on request.

Exova Warringtonfire rebranded to Warringtonfire on 1 December 2018. Apart from the change to our brand name, no other changes have occurred. The introduction of our new brand name does not affect the validity of existing documents previously issued by us.

Executive summary

This report documents the findings of the assessment undertaken to determine the expected fire resistance performance of uPVC and HDPE pipe penetration protected with Promaseal FCW wall collars in various configurations, accordance with AS 1530.4:2014 and AS 4072.1:2005. This assessment was carried out at the request of Promat Australia Pty Ltd.

The analysis conducted in sections 5 and 6 of this report found that the proposed variations are expected to achieve fire resistance level (FRL) as shown in Table 1 and Table 2, in accordance with AS 1530.4:2014 and AS 4072.1:2005, respectively.

Table 1 Variations and assessment outcome – uPVC pipes protected by Promaseal FCW Wall Collars

Nominal pipe diameter (mm)	Nominal Pipe wall thickness (mm)	Wall system description	Separating element thickness (mm)	Promaseal fire collar type	FRL (min)
40	2.6	2 × 13 mm ^a or 2 × 16 mm layers of plasterboard faced to both sides of a 64 mm steel stud.	116 or 128	FCW 40	-120/120
50	2.2-3.0			FCW 50	
65	2.9			FCW 65	
80	3.4			FCW 80 – omission of internal springs permitted	
100	3.4			FCW 100	
150	5.0			FCW 150	
40	2	AAC Hebel PowerPanels glued together with CSR Hebel adhesive using a 6mm deep notched trowel.	75	FCW 40	-180/90
50	2.6			FCW 50	
65	3.7			FCW 65	
80	3.4			FCW 80	
100	3.4-4			FCW 100	
40	2	Masonry and concrete with a density of at least 550 kg/m ³	128	FCW 40	-180/120
50	2.6			FCW 50	
65	3.7			FCW 65	
80	3.4			FCW 80	
100	3.4-4			FCW 100	
40	3	Vertically oriented separating element with 3×16mm layers of Fyrechek fire rated plasterboard (1800×1200 mm) installed vertically into a metal frame.	48	FCW 40	-120/90
50	2.6			FCW 50	
65	3.7			FCW 65	
80	3.4			FCW 80	
100	3.6			FCW 100	
40	3		90 or 96	FCW 40	-180/120
50	2.6			FCW 50	
65	3.7			FCW 65	
80	3.4			FCW 80	

Nominal pipe diameter (mm)	Nominal Pipe wall thickness (mm)	Wall system description	Separating element thickness (mm)	Promaseal fire collar type	FRL (min)
100	3.6	1×25 mm thick shaftwall liner with unexposed side fitted with 2×13 or 2×16 mm fire rated plasterboard.		FCW 100	
40	3	Speedpanel wall ^b	51	FCW 40	-/60/60
50	2.6			FCW 50	
65	3.7			FCW 65	
80	3.4			FCW 80	
100	3.6			FCW 100	
40	3		64	FCW 40	-/90/90
50	2.6			FCW 50	
65	3.7			FCW 65	
80	3.4			FCW 80	
100	3.6			FCW 100	
40	3		78	FCW 40	-/120/120
50	2.6			FCW 50	
65	3.7			FCW 65	
80	3.4			FCW 80	
100	3.6			FCW 100	

^aThe cavity in the 2 × 13 mm plasterboard system must be insulated using 75 mm thick R1.5 glasswool insulation batts

^bThe Speedpanel wall must be installed in accordance with procedures listed in their test or assessment reports to achieve the desired fire resistance levels. Please contact Speedpanel to obtain the correct and latest version of the evidence. Refer to pre-requisites summarized in Section 5.3.2 and Figure 14 (Service A and C) and Figure 15 for further details on installation of local fire-stopping systems.

Table 2 Variations and assessment outcome – HDPE pipes protected by Promaseal FCW Wall Collars

Nominal pipe diameter (mm)	Nominal Pipe wall thickness (mm)	Wall system description	Separating element thickness (mm)	Promaseal fire collar type	FRL (min)
50	3.2	2×13 mm ^c or 2×16mm layers of plasterboard faced to both sides of a 64 mm steel stud.	116 or 128	FCW Wall Collars.	-/120/120
63	3.2			Diameters to be adjusted to suite the pipe outside diameters and intumescent thickness to be 12 mm.	
75	3.2			Omission of internal springs is permitted.	
90	3.8				
40	As manufactured		75	FCW 40	-/180/120
50	3.2			FCW 50	

Nominal pipe diameter (mm)	Nominal Pipe wall thickness (mm)	Wall system description	Separating element thickness (mm)	Promaseal fire collar type	FRL (min)
65	As manufactured	AAC Hebel PowerPanels glued together with CSR Hebel adhesive using a 6mm deep notched trowel.		FCW 65	
80	As manufactured			FCW 80	
100	3.9			FCW 100	
40	As manufactured	Masonry and concrete with a density of at least 550 kg/m ³	128	FCW 40	
50	3.2			FCW 50	
65	As manufactured			FCW 65	
80	As manufactured			FCW 80	
100	3.9			FCW 100	
40	As manufactured	Speedpanel ^d wall	51	FCW 40	-/60/60
50	3.2			FCW 50	
65	As manufactured			FCW 65	
80	As manufactured			FCW 80	
100	3.9			FCW 100	
40	As manufactured		64	FCW 40	-/90/90
50	3.2			FCW 50	
65	As manufactured			FCW 65	
80	As manufactured			FCW 80	
100	3.9			FCW 100	
40	As manufactured		78	FCW 40	-/120/120
50	3.2			FCW 50	
65	As manufactured			FCW 65	
80	As manufactured			FCW 80	
100	3.9			FCW 100	
^c The cavity in the 2 × 13 mm plasterboard system must be insulated using 75 mm thick R1.5 glasswool insulation batts ^d The Speedpanel wall must be installed in accordance with procedures listed in their test or assessment reports to achieve the desired fire resistance levels. Please contact Speedpanel to obtain the correct and latest version of the evidence. Refer to pre-requisites summarized in Section 6.3.2 and Figure 14 (Service A and C) and Figure 15 for further details on installation of local fire-stopping systems.					

The variations and outcome of this assessment are subject to the limitations and requirements described in sections 2, 3 and 4 of this report. The results of this report are valid until 28 February 2025.

Contents

Amendment schedule	2
Contact information	3
General conditions of use	3
Executive summary	4
Contents	7
1. Introduction	9
2. Framework for the assessment	9
2.1 Declaration	9
2.2 Compliance with the National Construction Code	10
3. Description of the specimen and variations	10
3.1 System description	10
3.2 Referenced test data	10
3.3 Variations to tested system	16
3.4 Purpose of the test	17
3.5 Schedule of components	17
4. Scope, objectives and assumptions	39
4.1 Scope and objective	39
5. Assessment 1 – uPVC pipes protected by Promaseal FCW fire collars	40
5.1 Description of variations	40
5.2 Methodology	40
5.3 Assessment	40
5.3.1 Applicability of the tests in accordance with AS 1530.4:2014	40
5.3.2 Promaseal FCW Wall Collar protecting uPVC pipe penetrations	41
5.3.3 Changes in intumescent composition	46
5.3.4 General applicability conditions	46
5.4 Conclusion	46
6. Assessment 2 – HDPE pipe penetrations protected by Promaseal FCW fire collars	49
6.1 Description of variation	49
6.2 Methodology	49
6.3 Assessment	49
6.3.1 Applicability of the tests in accordance with AS 1530.4:2014	49
6.3.2 Promaseal FCW Wall Collar protecting HDPE pipe penetrations	49
6.4 Conclusion	51
7. Validity	53
Appendix A Summary of supporting test data	54
A.1 Test report – WFRA F91731.3	54
A.2 Test report – WFRA F91622	56
A.3 Test report – WFRA F91633	57
A.4 Test report – FSRG A-13-816	59
A.5 Test report – FSRG A-13-819	61
A.6 Test report – FSRG A-13-823A	63
A.7 Test report – FSRG A-14-879A	65
A.8 Test report – FSRG A-15-1011A	67
A.9 Test report – FSRG A-15-1038	69
A.10 Test report – FSRG A-12-775a	70
A.11 Test report – FSRG A-12-777	71
A.12 Test report – WFRA 2798800.1	72
Appendix B Relevance of AS 1530.4:1990 test data with respect to AS 1530.4:2014	73
B.1 General	73
B.2 Discussion	73

Appendix C Relevance of AS 1530.4:1997 test data with respect to AS 1530.4:2014.....75

C.1 General.....75

C.2 Discussion75

Appendix D Relevance of AS 1530.4:2005 test data with respect to AS 1530.4:2014.....77

D.1 General.....77

D.2 Discussion77

1. Introduction

This report documents the findings of the assessment undertaken to determine the expected fire resistance performance of uPVC and HDPE pipe penetration protected by Promaseal FCW wall collars in various configurations, in accordance with AS 1530.4:2014¹ and assessed in accordance with AS 4072.1-2005². This assessment was carried out at the request of Promat Australia Pty Ltd. The sponsor details are included in Table 3.

Table 3 Sponsor details

Client	Address
Promat Australia Pty Ltd	1 Scotland Rd Mile End SA, 5031 Australia

2. Framework for the assessment

An assessment is an opinion about the performance of a component or element of structure subject to a standard fire test.

No specific framework, methodology, standard or guidance documents exists in Australia for doing these assessments. Therefore, we have followed the Guide to Undertaking Assessments In Lieu of Fire Tests prepared by the Passive Fire Protection Federation (PFPF) in the UK³.

This guide provides a framework to undertake assessments in the absence of specific fire test results. 'Some areas where assessments may be offered are:

- *Where a modification is made to a construction which has already been tested*
- *Interpolation or extrapolation of results of a series of fire resistance tests, or utilisation of a series of fire test results to evaluate a range of variables in a construction design or a product*
- *Where, for various reasons – eg size or configuration – it is not possible to subject a construction or a product to a fire test.'*

Assessments will vary from relatively simple judgements on small changes to a product or construction through to detailed and often complex engineering assessments of large or sophisticated constructions.

2.1 Declaration

The guide to undertaking assessments in lieu of fire tests prepared by the PFPF in the UK requires a declaration from the client. By accepting our fee proposal dated 9 December 2019, Promat Australia Pty Ltd confirmed that

- To their knowledge the component or element of structure, which is the subject of this assessment, has not been subjected to a fire test to the standard against which this assessment is being made.
- They agree to withdraw this assessment from circulation if the component or element of structure is the subject of a fire test by a test authority in accordance with the standard against which this assessment is being made and the results are not in agreement with this assessment.
- They are not aware of any information that could adversely affect the conclusions of this assessment and – if they subsequently become aware of any such information, they agree to ask the assessing authority to withdraw the assessment.

¹ Methods for fire tests on building materials, components and structures Fire-resistance tests for elements of construction.

² Components for the protection of openings in fire-resistant separating elements Service penetrations and control joints

³ Guide to Undertaking Assessments In Lieu of Fire Test - The Passive Fire Protection Federation (PFPF), June 2000, UK.

2.2 Compliance with the National Construction Code

This assessment report has been prepared to meet the Evidence of Suitability requirements of the NCC 2019, including amendments⁴ under A5.2 (1) (d).

This assessment has been written in accordance with the general principles outlined in EN 15725:2010⁵ for extended application reports on the fire performance of construction products and building elements. It also references test evidence for meeting a performance requirement or deemed to satisfy (DTS) provision of the NCC under A5.4 for fire resistance levels, and as applicable to the assessed systems.

This assessment report may also be used to demonstrate compliance with the requirements for Evidence of Suitability under NCC 2016, including amendments⁶.

3. Description of the specimen and variations

3.1 System description

This report presents a considered opinion of the expected performance of nominated uPVC and HDPE pipe penetrations protected by Promaseal FCW wall collars, if subjected to a fire resistance test in accordance with AS 1530.4:2014 and relevant requirements of AS 4072.1-2005. The performance of the fire collars is considered when they are mounted in various configurations on pipe penetrations through separating elements and shaftwalls.

3.2 Referenced test data

The assessment of the variation to the tested system and the determination of the expected performance is based on the results of the fire test documented in the report summarised in Table 4. Further details of the tested system are described in Appendix A.

Table 4 Referenced test data

Report number	Test sponsor	Test date	Testing authority
WFRA F91622	*Fyreguard Pty Ltd	18 October 1995	Warrington Fire Research
WFRA F91633		4 December 1995	
WFRA F91731.3		30 June 1998	
FSRG A-13-816	Promat Australia Pty Ltd	21 March 2013	Fire Science Research Group (FSRG)
FSRG A-13-819		28 February 2013	
FSRG A-13-823A		15 May 2013	
FSRG A-14-879A		12 June 2014	
FSRG A-15-1011A		21 September 2015	
FSRG A-15-1038		21 January 2015	
FSRG A-12-775a		16 August 2012	
FSRG A-12-777		30 August 2012	
EWFA 2798800.1		Speedpanel (VIC) Pty Ltd	

* The original sponsor of the test, Fyreguard Pty Ltd, is now named Promat Australia Pty Ltd.

A summary of the considered tested service penetrations and the results from these fire tests are presented in Table 5.

⁴ National Construction Code Volumes One and Two - Building Code of Australia 2019 including Amendments, Australian Building Codes Board, Australia

⁵ European Committee for Standardization, 2010, Extended application reports on the fire performance of construction products and building elements, EN 15725:2010, European Committee for Standardization, Brussels, Belgium.

⁶ National Construction Code Volumes One and Two - Building Code of Australia 2016 including Amendments, Australian Building Codes Board, Australia

Table 5 Reference test details and results

Test	Pipe type	Nominal pipe diameter (mm)	Pipe wall thickness (mm)	Wall system description	separating element thickness (mm)	Main fire stopping system	Intum. Material length (mm)	Intum. Material thickness (mm)	Local fire stopping system	Aperture size (mm)	FRL (min)
WFRA F91731.3	uPVC	50	2.2	Vertically oriented partition (3200×3200 mm) with 1×9 mm layer of Promina plasterboard faced to both sides of a 50 mm steel stud. Each stud was faced over with a 100 mm wide strip of 9 mm Promina plasterboard. The cavity between the plasterboard and steel framing was filled with rockwool material.	90	3 layers of Promaseal intumescent wrap configured in series	95	11	Promaseal mastic, non-fire rated silicon sealant	80	-/120/45
		40	2.3							67	-/120/45
		65	2.8							106	-/120/45
	HDPE	63	3.2							83	-/120/60
		75	3.2							92	-/120/60
	uPVC	80	3.2							107	-/120/45
		HDPE	50							3.2	80
										90	3.8
WFRA F91622	uPVC	40	2.6	Vertically oriented partition (1100×1100 mm) with 2×16 mm layers of Fyrchek plasterboard faced to both sides of a 64 mm steel stud.	128	Internally mounted Fyreguard ⁷ Insert Wall Collar	98	1.2	Fyreseal Mastic sealant	90	-/120/120
		65	2.9							115	-/120/120
		80	3.4							145	-/120/120
WFRA F91633		100	3.4							170	-/120/120
		50	3.0							110	-/120/120
		150	5.0							220	-/90/120
FSRG A-13-816	uPVC	50	2.6		75	Internally mounted Promaseal FCW 50 fire collar	NA	NA	NA	-/180/120	

⁷ The original sponsor of the test and assessment was Fyreguard Pty Ltd, which is now named Promat Australia Pty Ltd. Promat Australia Pty Ltd have confirmed in writing that trade name of the tested product is Promaseal FCW Wall Collar.

Test	Pipe type	Nominal pipe diameter (mm)	Pipe wall thickness (mm)	Wall system description	separating element thickness (mm)	Main fire stopping system	Intum. Material length (mm)	Intum. Material thickness (mm)	Local fire stopping system	Aperture size (mm)	FRL (min)
		100	3.4	Vertically oriented separating element consisting of 2x1800x600 Hebel power panel blocks of 75 mm glued together with CSR Hebel adhesive.		Internally mounted Promaseal FCW 100 fire collar	NA	NA	Promaseal AN Acrylic sealant on unexposed side	NA	-/180/120
FSRG A-14-879A	uPVC	100	4	Vertically oriented separating element consisting of 3x1800x600 Hebel power panel blocks of 75 mm glued together with CSR Hebel adhesive.	75	Internally mounted Promaseal FCW 100 fire collar	NA	NA	Promaseal AN Acrylic sealant on unexposed side	NA	-/180/90
		40	2			Internally mounted Promaseal FCW 40 fire collar	NA	NA		NA	-/180/90
FSRG A-15-1011	HDPE	100	3.9	Vertically oriented separating element consisting of 3x1800x600 Hebel power panel blocks of 75 mm glued together with CSR Hebel adhesive.	75	Internally mounted Promaseal FCW 100 fire collar	NA	NA	Promaseal IBS, Promaseal AN Acrylic sealant	NA	-/180/180
	uPVC	65	3.7			Internally mounted Promaseal FCW 65 fire collar	NA	NA		NA	-/180/180
	HDPE	50	3.2			Internally mounted Promaseal FCW 50 fire collar	NA	NA		NA	-/180/180
FSRG A-15-1038	HDPE	100	2.5			Internally mounted Promaseal FCW 100 fire collar	NA	NA	Promaseal - A Acrylic sealant	NA	-/180/90

Test	Pipe type	Nominal pipe diameter (mm)	Pipe wall thickness (mm)	Wall system description	separating element thickness (mm)	Main fire stopping system	Intum. Material length (mm)	Intum. Material thickness (mm)	Local fire stopping system	Aperture size (mm)	FRL (min)
FSRG A-13-823A	uPVC	100	3.6	Vertically oriented separating element with 3x16mm layers of Fyrechek fire rated plasterboard (1800x1200 mm) installed vertically into a metal frame.	48	Promaseal FCW 100 fire collar installed flush with separating element on the unexposed side	NA	NA	Promaseal AN Acrylic sealant	NA	-/-
		40	3			Promaseal FCW 40 fire collar installed flush with separating element on the unexposed side	NA	NA		NA	-/120/60
		100	3.6			Internally mounted Promaseal FCW 100 fire collar	NA	NA		NA	-/120/90
		40	3			Internally mounted Promaseal FCW 40 fire collar	NA	NA		NA	-/120/120
FSRG A-13-819	uPVC pipe	100	4.3		90	Promaseal FCW 100 fire collar installed flush with separating element on the exposed side	NA	NA	Promaseal AN Acrylic sealant	NA	-/120/120
		40	2			Promaseal FCW 40 fire collar installed flush with separating element on the exposed side	NA	NA		NA	-/120/120

Test	Pipe type	Nominal pipe diameter (mm)	Pipe wall thickness (mm)	Wall system description	separating element thickness (mm)	Main fire stopping system	Intum. Material length (mm)	Intum. Material thickness (mm)	Local fire stopping system	Aperture size (mm)	FRL (min)
	uPVC service with 90 deg junction on unexposed side	100	4.3	Vertically oriented separating element consisting of 3x1800x600 mm sheets of shaftwall liner 25 mm thick each, fitted within a metal frame. The unexposed side of the system was fitted with two layers of 13 mm fire rated plasterboard.		Promaseal FCW 100 fire collar on unexposed side (thickened around the penetration by 4 layers of 20 mm thick VERMICULUX) and Promaseal UniCollar installed within separating element on exposed side.				NA	-/120/120
EWFA 2798800.1	uPVC	40	2	Speedpanel wall	51	Promaseal FCW 40	NA	NA	Hilti CP606 mastic	95	-/120/-
		100	3.7			Promaseal FCW 100	NA	NA		165	-/120/-
FSRG A-12-775a	uPVC	40	2	Speedpanel wall	75	Promaseal FCW 40	NA	NA	Promaseal SupaMastic and 25 mm Promatect 100	NA	-/240/180
		100	4			Promaseal FCW 100	NA	NA		Promaseal SupaMastic and 25 mm Promatect 100	NA

Test	Pipe type	Nominal pipe diameter (mm)	Pipe wall thickness (mm)	Wall system description	separating element thickness (mm)	Main fire stopping system	Intum. Material length (mm)	Intum. Material thickness (mm)	Local fire stopping system	Aperture size (mm)	FRL (min)
FSRG A-12-777	HDPE	100	5.6	Speedpanel wall	75	Promaseal FCW 100	NA	NA	Promaseal SupaMastic and 25 mm Promatect 100	NA	-/120/120
FSRG A-12-777	HDPE	40	3.8	Speedpanel wall	75	Promaseal FCW 40	NA	NA	Promaseal SupaMastic and 25 mm Promatect 100	NA	-/120/120

3.3 Variations to tested system

An identical system has not been subject to a standard fire test. We have therefore assessed the systems using baseline test information for similar systems. The variations to the tested systems together with the referenced baseline standard fire tests are described in Table 6.

Table 6 Variation to tested systems

Assessment number	Reference tests	Description	Variations
1	WFRA F91731.3 (AS 1530.4:1997), WFRA F91622 and WFRA F91633 (in accordance with AS 1530.4:1990) FSRG A-13-819, FSRG A-13-816, FSRG A-14-879A, FSRG A-15-1011 and FSRG A-15-1038, FSRG A-13-823A (in accordance with AS 1530.4:2005)	The separating elements were 75 mm thick vertical Hebel panels, 90 mm shaftwall liner and steel stud plasterboard partition walls (48, 90, 116 and 128 mm thick). Nominated services include uPVC pipe penetrations of various sizes protected by Promaseal FCW fire collars. Refer to Figure 1 to Figure 12 for details.	Assessment of the applicability of the results in accordance with AS 1530.4:2014 and AS 4072.1-2005. Assessment of the expected performance of Promaseal FCW fire collars protecting uPVC pipe penetrations in below separating elements: <ul style="list-style-type: none"> Plasterboard partition wall with nominal thickness of 116 mm or 128 mm. The fire collars are to be identical to those described in tests WFRA F91622 and WFRA F91633, except the internal spring, are to be removed from the 80 mm size fire collar. AAC with a nominal thickness of 75 mm as tested in FSRG A-13-816, FSRG A-14-879A and FSRG A-15-1011. Solid plasterboard partition wall with nominal thickness of 48 mm (including 3x16 mm layers) as tested in FSRG A-13-823A. Shaftwall liner with overall thickness of 90 mm (3x1800x600 mm sheets of shaftwall liner 25 mm thick each with 2x13 mm fire rated plasterboard on unexposed side) as tested in FSRG A-13-819 and 96 mm (proposed). Masonry and concrete with a thickness not less than 128mm.
2	F91622 and F91633 (in accordance with AS 1530.4:1990) FSRG A-13-816, FSRG A-14-879A, FSRG A-15-1011 and FSRG A-15-1038 (in accordance with AS 1530.4:2005)	The separating elements were 75 mm thick vertical Hebel panels and 90 mm steel stud plasterboard partition walls. Nominated services include HDPE pipe penetrations of various sizes protected by Promaseal FCW fire collars.	Assessment of the applicability of the results in accordance with AS 1530.4:2014 and AS 4072.1-2005. Assessment of the expected performance of Promaseal FCW fire collars protecting HDPE pipe penetrations in below separating elements: <ul style="list-style-type: none"> Plasterboard partition wall with nominal thickness of 128 mm. The fire collars are to be similar to those described in tests WFRA F91622 and WFRA F91633 except the collar diameters are adjusted to suite the pipe outside diameters, the internal springs are not fitted on any collar sizes and the intumescent thickness shall be 12 mm. AAC with a nominal thickness of 75 mm as tested in FSRG A-15-1038 and FSRG A-15-1011. Masonry and concrete with a thickness not less than 128mm.

Assessment number	Reference tests	Description	Variations
3	EWFA 2798800.1 FSRG A-12-775a FSRG A-12-777	51 mm, 64 mm, and 78 mm thick Speedpanel walls. Nominated services include uPVC and HDPE pipe penetrations of various sizes protected by Promaseal FCW fire collars.	Assessment of the applicability of the results in accordance with AS 1530.4:2014 and AS 4072.1-2005. Assessment of the expected performance of Promaseal FCW fire collars protecting 40-100 mm uPVC and HDPE pipe penetrations using construction methods in EWFA2798800.1, FSRG A-12-775a and FSRG A-12-777.

3.4 Purpose of the test

Section 2 of AS 1530.4:2014 sets out the general requirements for conducting fire resistance tests, and section 10 of the Standard specifies guidelines for determining the fire resistance of elements of construction penetrated by services such as pipes. AS 4072.1-2005 sets out the minimum requirements for the construction, installation and application of fire resistance tests to sealing systems. These include pipes penetrating through building elements that are required to have a fire resistance level (FRL).

Furthermore, AS 4072.1-2005 specifies the requirements for pre-qualification for assessment of variations of PVC-U DWV (uPVC) pipes as follows. All the following tested plastic pipe sizes shall achieve the required FRL as set out in Clause 4.6.3 of AS 4072.1-2005⁸:

- 40 mm
- 50 mm
- 65 mm
- 80 mm
- 100 mm

All the above uPVC pipe sizes have been tested and considered to have achieved the required FRL as discussed in 5 and 6 of the report. For plastic pipes other than uPVC (such as HDPE), an opinion may be given provided that the following criteria are met:

- The maximum and minimum sizes of the assessed pipes have been tested and achieved the required FRL in the subject separating element
- The outside diameter of the largest pipe does not exceed 120 mm
 - For all pipes with outside diameters greater than 120 mm, testing in accordance with AS 1530.4:2014 is recommended.
- The outside diameter of the smallest pipe is not less than 40 mm
- The requirements of Clause 4.6.3 have been satisfied.

3.5 Schedule of components

Table 7 outlines the schedule of components for the assessed systems subject to a fire test.

Table 7 Schedule of components of assessed systems

Item	Description	
Partition wall / separating element		
1	Item	Steel Stud Promina plasterboard partition wall
	Description	1 × 9 mm layer of Promina plasterboard faced to both sides of a 50 mm steel stud. Each stud was faced over with a 100 mm wide strip of 9 mm Promina plasterboard – Refer to Figure 1 and Figure 2 for details.
	Size	3200 mm wide × 3200 mm long × 86 mm thick

⁸ AS 4072:2005, Components for the protection of openings in fire-resistant separating elements. Part 1: Service penetrations and control joints, Standards Australia, Australia.

Item	Description	
	Orientation	Vertical
2	Item	Steel Stud plasterboard partition wall
	Description	2 x 13 mm or 2 x 16 mm layers of plasterboard faced to both sides of a 64 mm steel stud tested or assessed to -/120/120 in accordance with AS 1530.4:2014 – Refer to Figure 3 and Figure 4 for details.
	Size	1100 mm wide x 1100 mm long x 128 mm thick
	Orientation	Vertical
3	Item	Steel Stud plasterboard partition wall
	Description	3 x 16 mm layers of fire rated plasterboard faced to both sides of a metal frame – Refer to Figure 5 for details.
	Size	1800 mm x 1200 mm – 48 mm thick
	Orientation	Vertical
4	Item	Hebel power panel separating element
	Description	2 x 1800 x 600 and 3 x 1800 x 600 Hebel power panel blocks of 75 mm thickness glued together with CSR Hebel adhesive using a 6 mm deep notched trowel – refer Figure 6 to Figure 10 for details.
	Size	600 mm wide x 1800 mm long x 75 mm (overall thickness)
	Orientation	Vertical
5	Item	Shaftwall separating element
	Description	3 x 1800 x 600 sheets of shaftwall liner 25 mm thick each fitted within a metal frame – Refer to Figure 11 for details. The unexposed side of the system was fitted with two layers of 13 mm fire rated plasterboard Overall thickness of specimen is 90 mm (tested) and 96 mm (proposed).
	Size	600 mm wide x 1800 mm long x 75 mm thick
	Orientation	Vertical
6	Item	Speedpanel wall
	Description	Aerated concrete core encased in a galvalised steel skin
	Orientation	Vertical
	Thickness	51 mm, 64 mm and 78 mm
Fire-stopping protections		
Sealants		
7	Product name	Promaseal mastic
	Density	NA
	Installation	As tested
8	Product name	Non-fire rated silicon sealant
	Density	NA
	Installation	As tested
9	Product name	Promaseal® -AG acrylic intumescent sealant
	Density	NA
	Installation	As tested
10	Product name	Fyreseal Mastic sealant
	Density	NA
	Installation	As tested

Item	Description			
11	Product name	Promaseal AN Acrylic sealant		
	Density	NA		
	Installation	As tested		
12	Product name	Promaseal -A Acrylic sealant		
	Density	NA		
	Installation	As tested		
13	Product name	Hilti CP 606 Mastic		
	Installation	As tested		
14	Product name	Promatect 100		
	Thickness	25 mm		
	Installation	As tested		
Backing Rod				
14	Item name	IBS backing rod		
	Product name	Promaseal IBS		
	Size	100 mm wide x 10 mm thick		
	Density	Nominal 306 kg/m ³		
	Installation	As tested		
Fire collars				
15	Item name	Promaseal fire collar		
	Product name	Promaseal FCW Wall Collar		
	Intumescent details	Grafitex cut out 9 x 9 mm to accommodate springs – refer to Figure 12 for details.		
	Collar details	Outer casing of 1 mm Zinc steel. Springs are fitted to collar sizes of 150 mm, 100 mm and 80 mm. Springs on 80 mm size fire collars are proposed to be removed for uPVC pipes (assessment 1). Internal springs are not to be fitted for fire collars protecting HDPE pipe penetrations through plasterboard partition walls, and the intumescent thickness is to be 12 mm for HDPE pipes (assessment 2).		
	Canister details (all dimensions in mm)			
	Size	Inner diameter	Outer diameter	Grafitex
	40	45	70	12
	50	58	84	12
	65	71	97	12
	80	85	110	18
100	113	150	18	
150	163	200	18	
	Installation	As tested		
16	Item name	Promaseal Fire collar		
	Product name	Promaseal FCW 50		
	Intumescent details	As manufactured.		
	Collar details	As manufactured		

Item	Description	
	Density	Nominal 970 kg/m ³ as tested
	Installation	Inserted centrally within the Hebel wall panel, protruding 22 mm out of the wall on both sides. Annular gap sealed with Promaseal AN Acrylic sealant (item 11).
17	Item name	Promaseal Fire collar
	Product name	Promaseal FCW 100
	Intumescent details	As manufactured.
	Collar details	As manufactured
	Density	Nominal 1015 kg/m ³ as tested
	Installation	Inserted centrally within the Hebel wall panel protruding 22 mm out of the wall on both sides. Annular gap sealed with Promaseal AN Acrylic sealant (item 11).
18	Item name	Promaseal Fire collar
	Product name	Promaseal FCW 100
	Intumescent details	As manufactured
	Collar details	As manufactured
	Density	Nominal 990 kg/m ³ as tested
	Installation	Inserted within the Hebel wall panel wall protruding 30 mm from unexposed side and flush with the exposed side. Annular gap was sealed with Promaseal AN Acrylic sealant (item 11). Sealant was also applied 30 mm on the collar and the wall.
19	Item name	Promaseal Fire collar
	Product name	Promaseal FCW 40
	Intumescent details	As manufactured
	Collar details	As manufactured
	Density	Nominal 990 kg/m ³ as tested
	Installation	Inserted within the Hebel wall panel wall protruding 30 mm from unexposed side and flush with the exposed side. Annular gap was sealed with Promaseal AN Acrylic sealant (item 11). Sealant was also applied 30 mm on the collar and the wall.
20	Item name	Promaseal Fire collar
	Product name	Promaseal FCW 100
	Intumescent details	As manufactured.
	Collar details	As manufactured
	Density	Nominal 990 kg/m ³ as tested
	Installation	Inserted centrally within the Hebel wall panel wall protruding 22 on both sides of the wall. Promaseal IBS (item 12) was used to wrap the protruding ends of the collar on both sides, with Promaseal AN Acrylic sealant (item 11) used to seal the gaps.
21	Item name	Promaseal Fire collar
	Product name	Promaseal FCW 65

Item	Description	
	Intumescent details	As manufactured
	Collar details	As manufactured
	Density	Nominal 990 kg/m ³ as tested
	Installation	Inserted centrally within the Hebel wall panel wall protruding 22 on both sides of the wall. Promaseal IBS (item 12) was used to wrap the protruding ends of the collar on both sides, with Promaseal AN Acrylic sealant (item 11) used to seal the gaps.
22	Item name	Promaseal Fire collar
	Product name	Promaseal FCW 50
	Intumescent details	As manufactured.
	Collar details	As manufactured
	Density	Nominal 990 kg/m ³ as tested
	Installation	Inserted centrally within the Hebel wall panel wall protruding 22 on both sides of the wall. Promaseal IBS (item 12) was used to wrap the protruding ends of the collar on both sides, with Promaseal AN Acrylic sealant (item 11) used to seal the gaps.
23	Item name	Promaseal Fire collar
	Product name	Promaseal FCW 100
	Intumescent details	As manufactured
	Collar details	As manufactured
	Density	Nominal 990 kg/m ³ as tested
	Installation	Inserted centrally within the separating element, protruding 20 mm on both sides of the wall. Promaseal -A Acrylic sealant (item 11) used to seal the gaps.
24	Item name	Promaseal Fire collar
	Product name	Promaseal FCW 40
	Intumescent details	As manufactured
	Collar details	As manufactured
	Density	Nominal 1015 kg/m ³ as tested
	Installation	Inserted centrally within the separating element protruding 36 mm on both sides of the wall. Promaseal AN Acrylic sealant (item 11) used to seal the gaps.
25	Item name	Promaseal Fire collar
	Product name	Promaseal FCW 100
	Intumescent details	As manufactured
	Collar details	As manufactured
	Density	Nominal 990 kg/m ³ as tested
	Installation	Inserted within the separating element flush with the unexposed side and protruding 72 mm on exposed side of the wall. Promaseal AN Acrylic sealant (item 11) used to seal the gaps.

Item	Description	
26	Item name	Promaseal Fire collar
	Product name	Promaseal FCW 40
	Intumescent details	As manufactured
	Collar details	As manufactured
	Density	Nominal 990 kg/m ³ as tested
	Installation	Inserted within the separating element flush with the unexposed side and protruding 72 mm on exposed side of the wall. Promaseal AN Acrylic sealant (item 11) used to seal the gaps.
27	Item name	Promaseal Fire collar
	Product name	Promaseal FCW 100
	Intumescent details	As manufactured
	Collar details	As manufactured
	Density	Nominal 970 kg/m ³ as tested
	Installation	Inserted within the separating element flush with the exposed side and protruding 30 mm on exposed side of the wall. Promaseal AN Acrylic sealant (item 11) used to seal the annular gap.
28	Item name	Promaseal Fire collar
	Product name	Promaseal FCW 40
	Intumescent details	As manufactured
	Collar details	As manufactured
	Density	Nominal 970 kg/m ³ as tested
	Installation	Inserted within the separating element flush with the exposed side and protruding 30 mm on exposed side of the wall. Promaseal AN Acrylic sealant (item 11) used to seal the annular gap.
29	Item name	Promaseal Fire collar
	Product name	Promaseal FCW 100
	Intumescent details	As manufactured
	Collar details	As manufactured
	Density	Nominal 970 kg/m ³ as tested
	Installation	Inserted flush with the unexposed side and thickened around the penetration by 4 layers of 20 mm thick VERMICULUX. Promaseal AN Acrylic sealant (item 11) used to seal the annular gap.
30	Item name	Promaseal Fire collar
	Product name	Promaseal UniCollar
	Intumescent details	As manufactured
	Collar details	As manufactured
	Density	Nominal 870 kg/m ³ as tested
	Installation	Inserted within the separating element as tested.
Wrap		

Item	Description	
31	Product name	Promaseal Wall Wrap
	Size	11 mm thick
	Material density	NA
	Installation	3 layers of 40 mm wide strips wrapped around pipe and configured in series as tested – Refer to Figure 2 for details.
Service penetrations		
32	Item type	uPVC pipes with below nominal outer diameters: Ø40 mm Ø50 mm Ø65 mm Ø80 mm Ø100 mm Ø150 mm
	Product name	As manufactured/tested.
33	Item type	HDPE pipes with below nominal outer diameters: Ø40 mm Ø50 mm Ø65 mm Ø80 mm Ø100 mm
	Product name	As manufactured/tested.

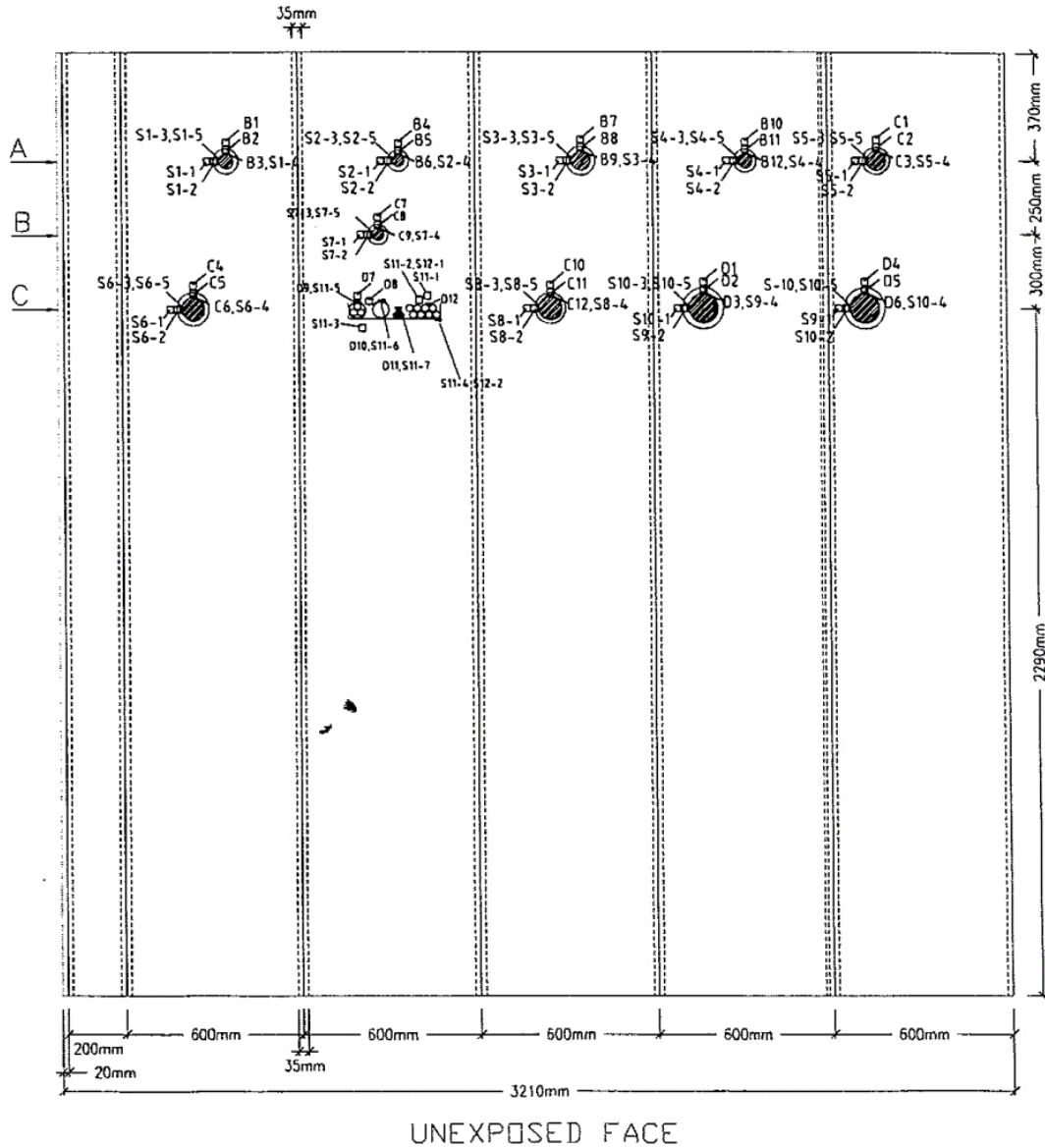

Figure 1 Test specimen (unexposed side) and cut hole locations as shown in WFR A F91731.3 – dimensions in mm

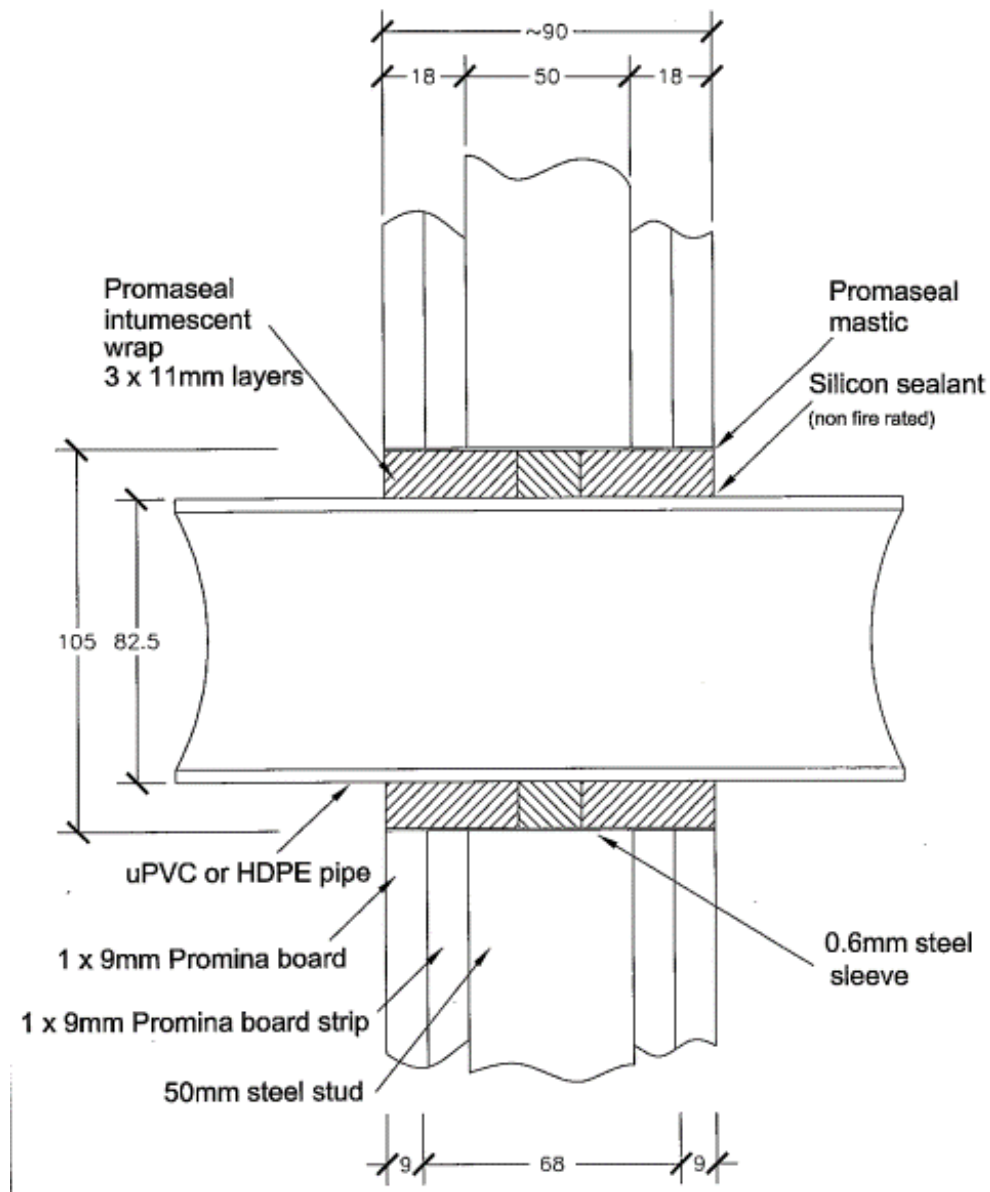
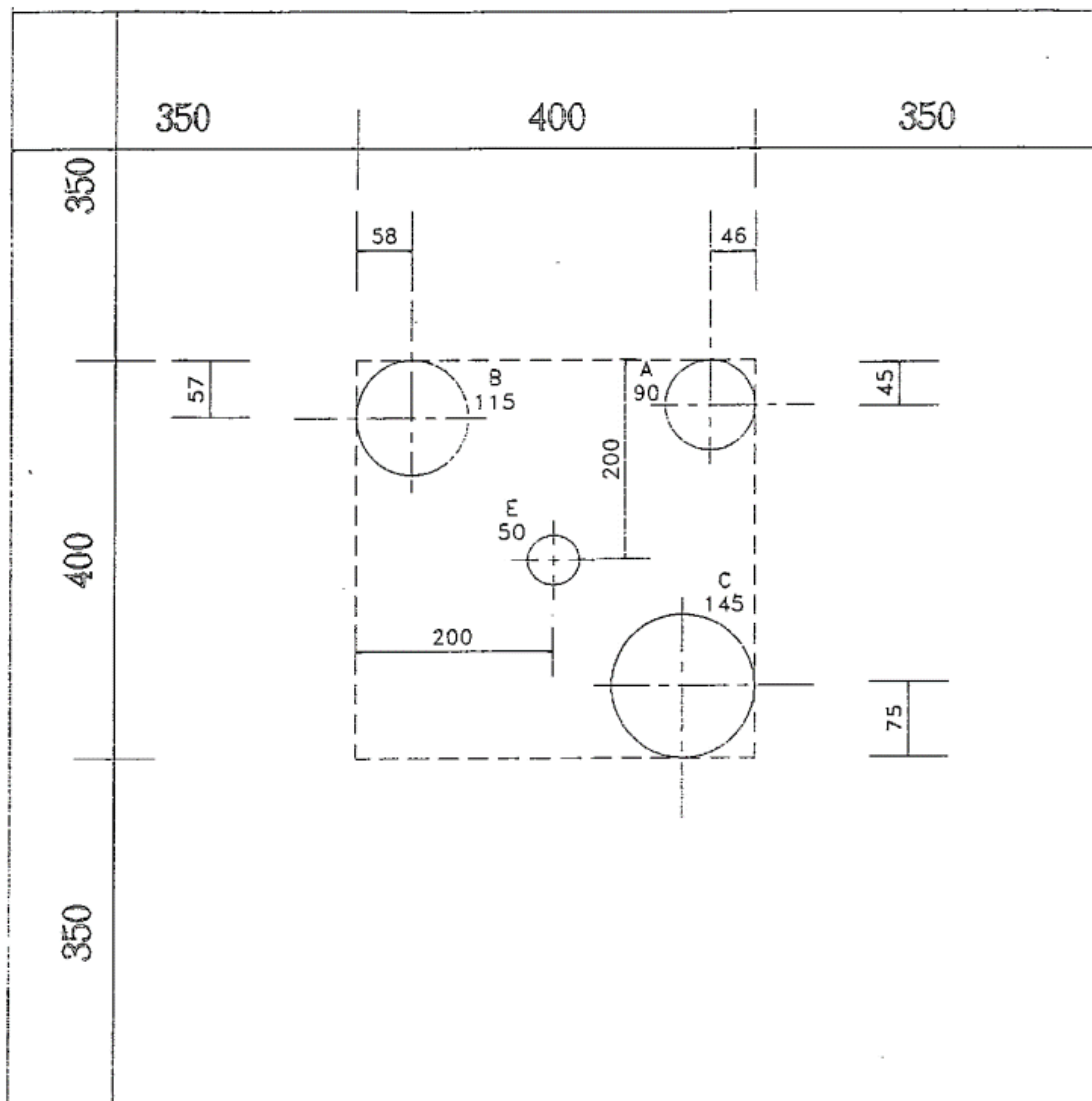

Figure 2 Cross section side of partition wall and pipe penetration as shown in WFRA F91731.3 – dimensions in mm



Description

Two 16 mm 'Fyrchek' boards each side of 64 mm steel stud.

- A 40 mm I.D. uPVC pipe 'Wall Collar' no spring
- B 65 mm I.D. uPVC pipe 'Wall Collar' no spring
- C 80 mm I.D. uPVC pipe 'Wall Collar' with spring
- E 25 mm conduit 'Grafitex' to depth of 2 x 16 mm
'Fyrchek' boards on both faces

Figure 3 Plan view of test specimen and cut hole locations as shown in WFRA F91622 – dimensions in mm

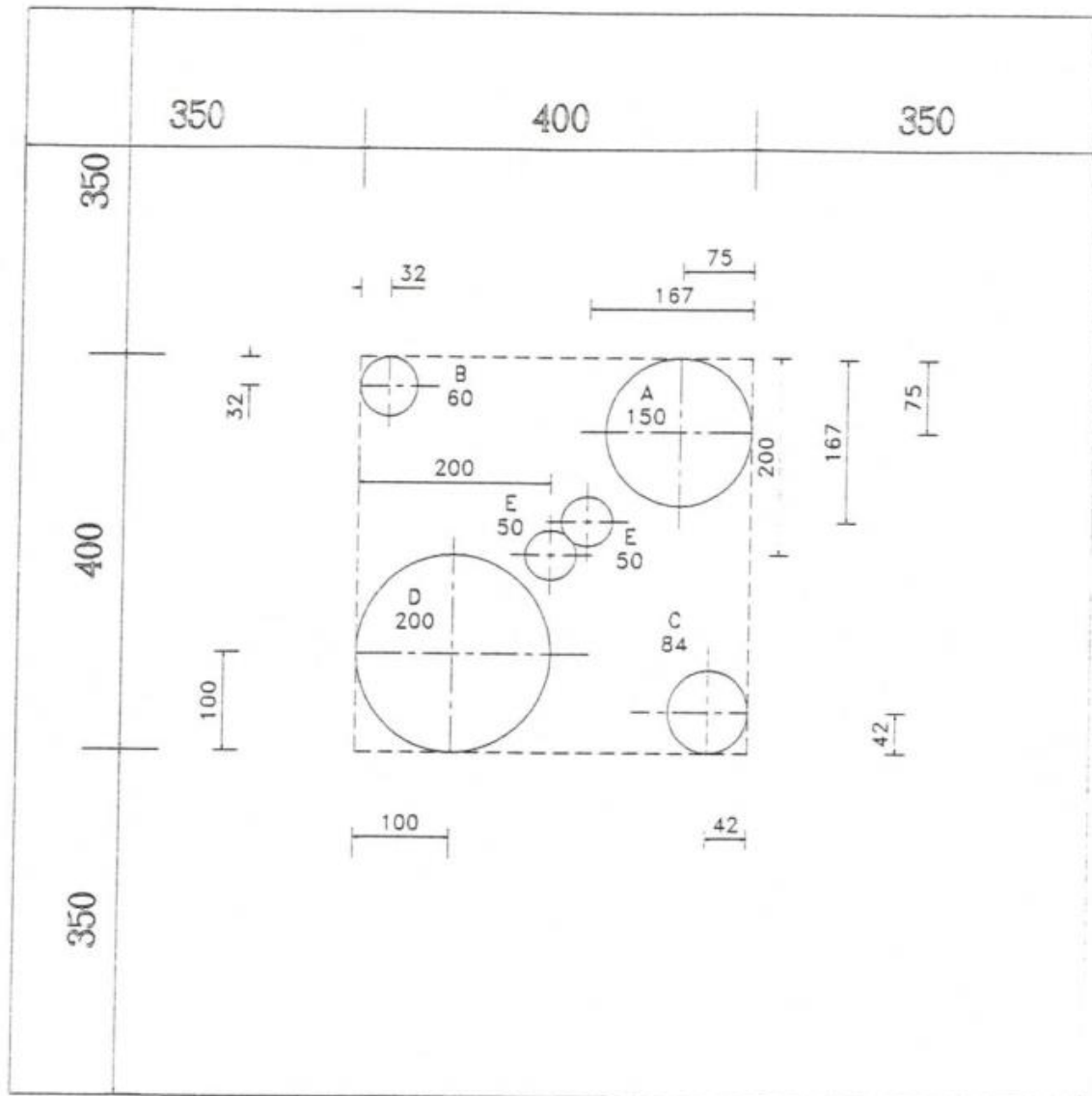

Description

Two 16 mm 'Fyrchek' boards each side of 64 mm steel stud.

- A 100 mm I.D. uPVC pipe "Wall Collar" with spring
- B 19 mm O.D. copper pipe with 9.5 Aeroflex
- C 50 mm I.D. uPVC pipe "Wall Collar" no spring
- D 150 mm I.D. uPVC pipe "Wall Collar" with spring
- E 32 mm O.D. XLPE pipe and 19 mm copper pipe with "Kemlag" green rubber insulation

Figure 4 Plan view of test specimen and cut hole locations as shown in WFRA F91633 – dimensions in mm

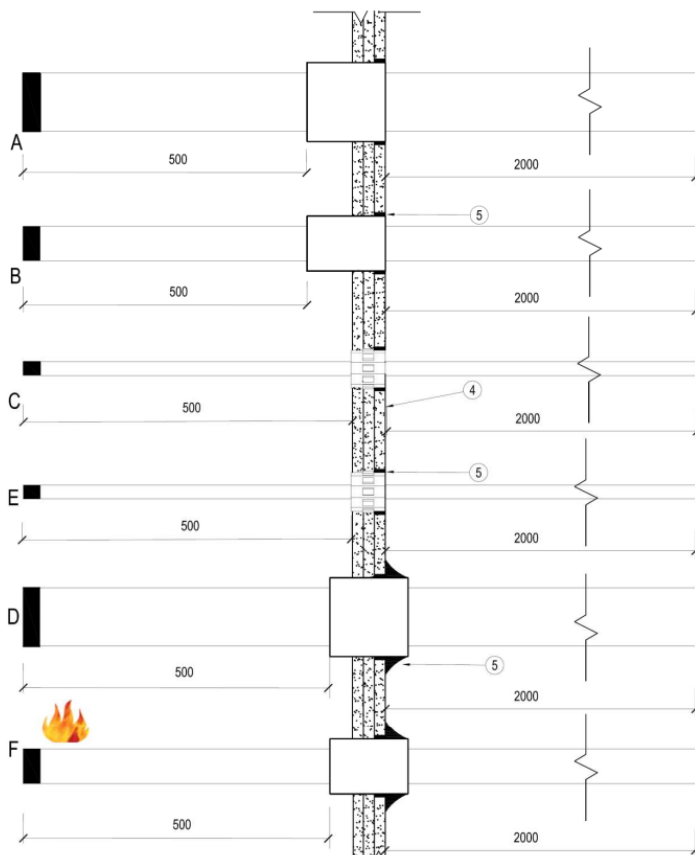
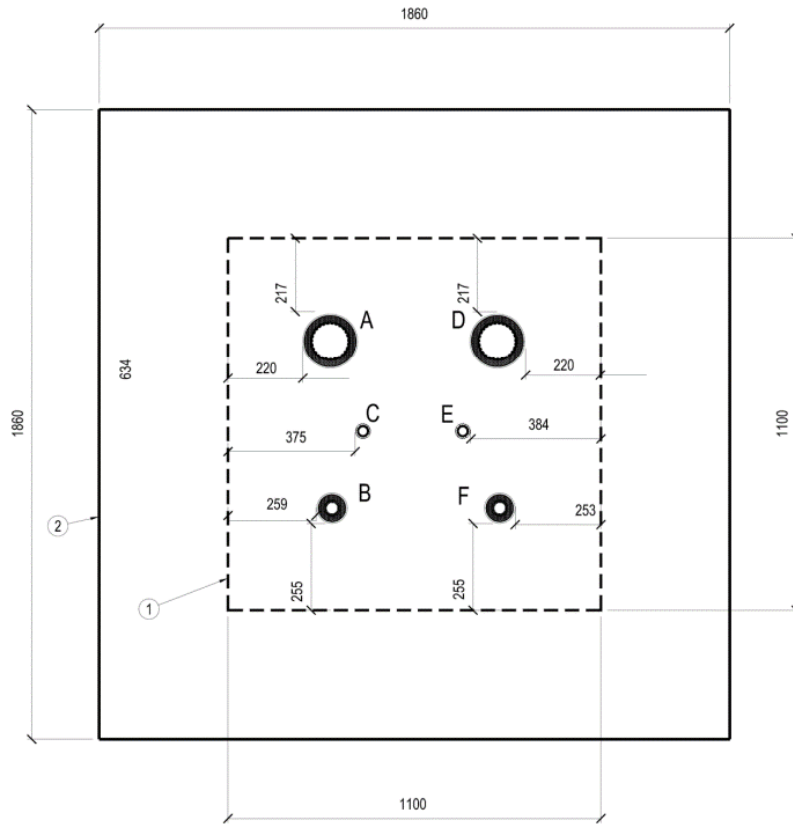

Figure 5 Plan view and cross section of test specimen and cut hole locations as shown in FSRG A-13-823A – dimensions in mm

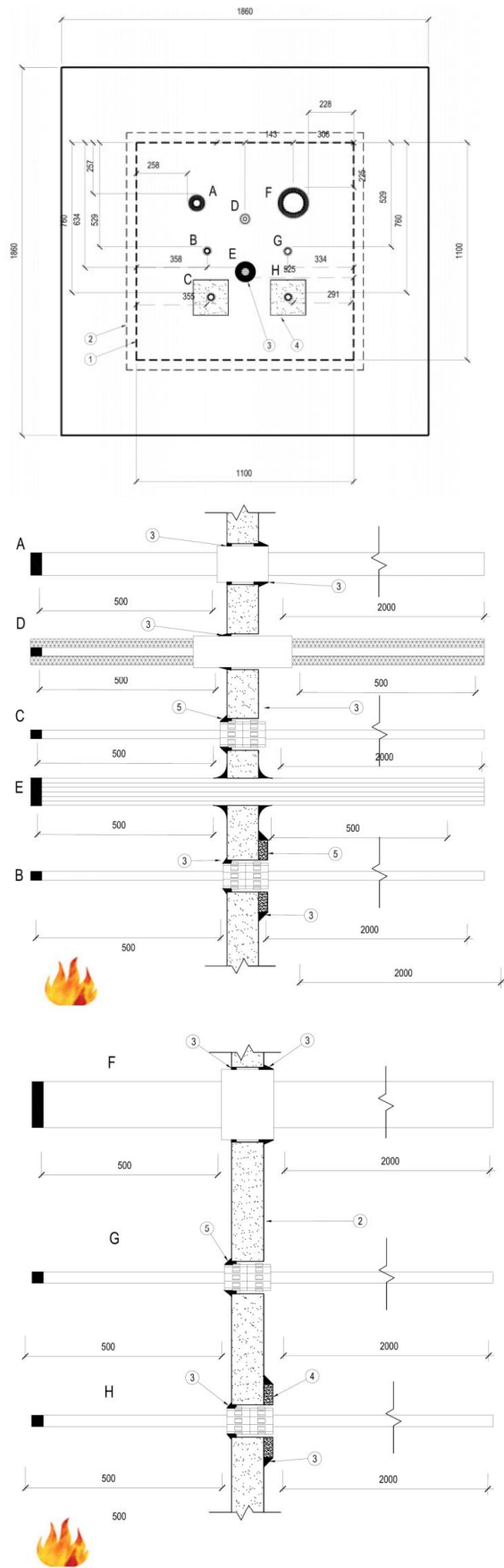

Figure 6 Plan view and cross sections of test specimen and cut hole locations as shown in FSRG A-13-816 – dimensions in mm

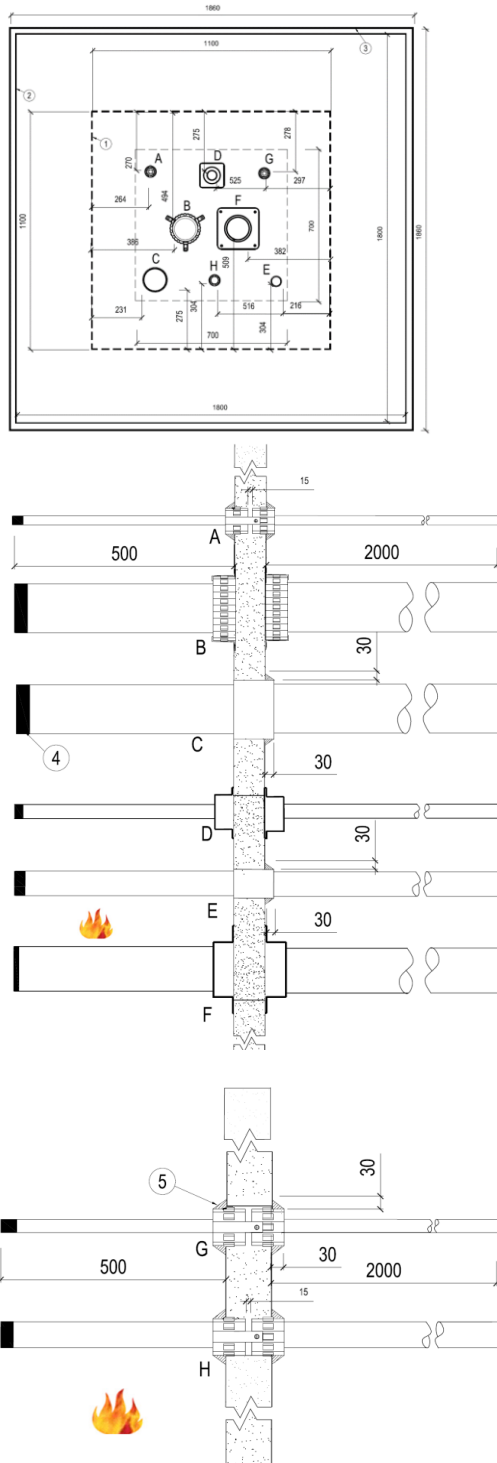

Figure 7 Plan view and cross sections of test specimen and cut hole locations as shown in FSRG A-14-879A – dimensions in mm

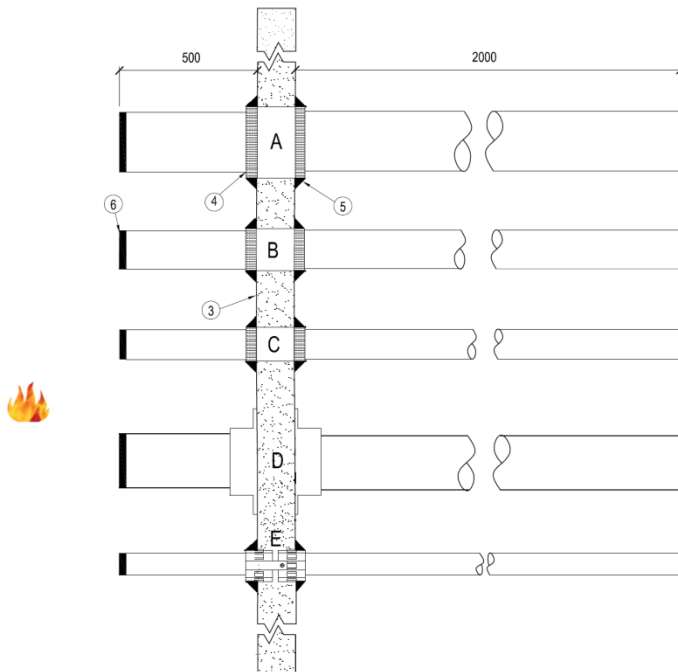
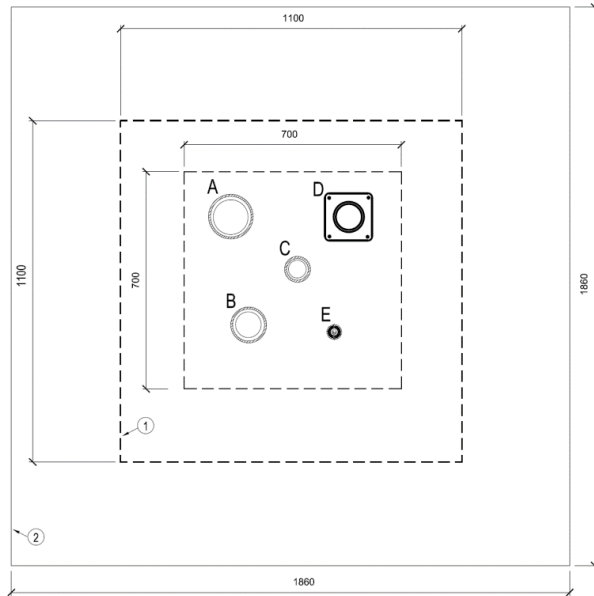

Figure 8 Plan view and cross sections of test specimen and cut hole locations as shown in FSRG A-15-1011A – dimensions in mm

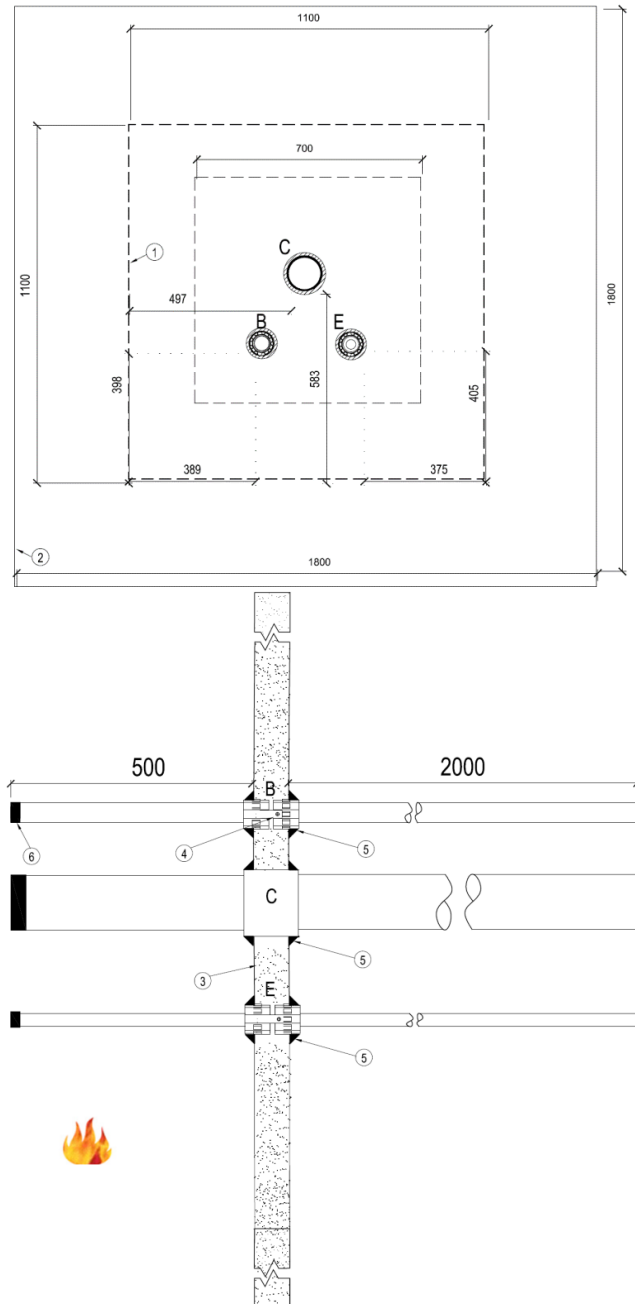

Figure 9 Plan view and cross sections of test specimen and cut hole locations as shown in FSRG A-15-1038 – dimensions in mm

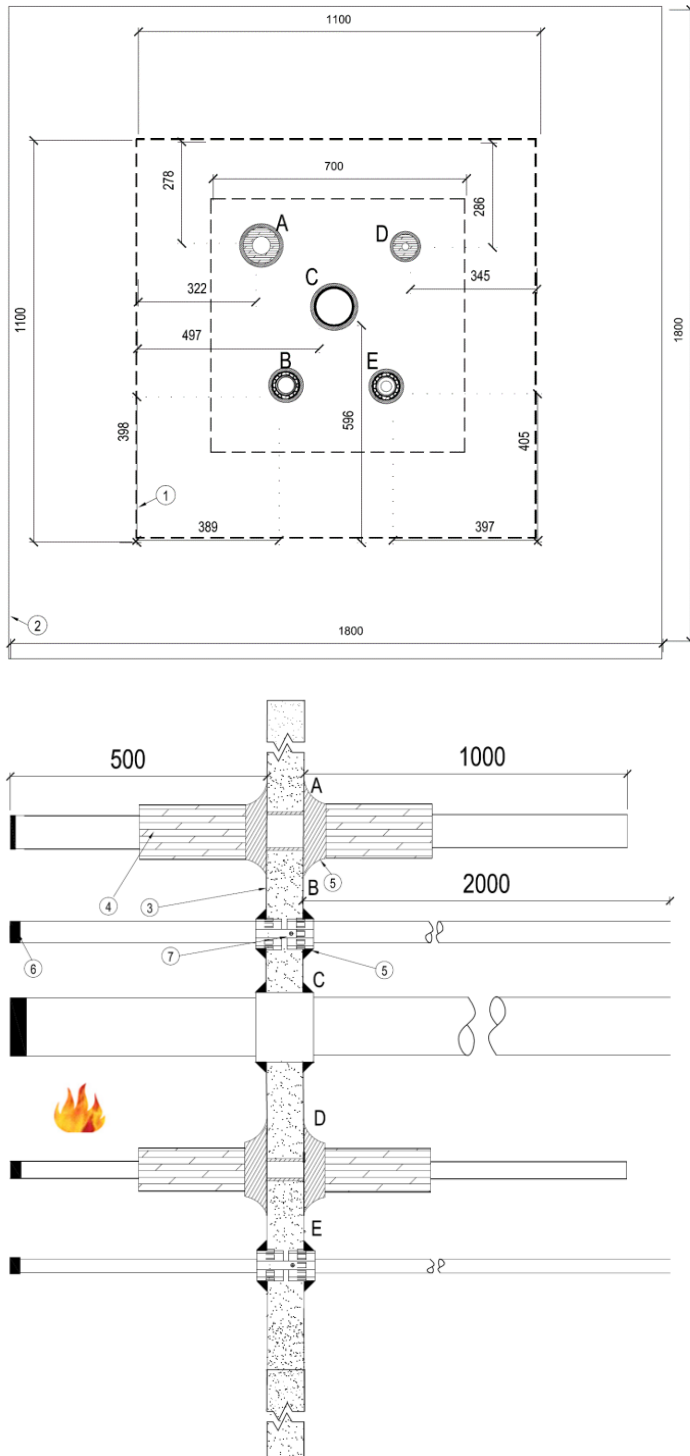

Figure 10 Plan view and cross sections of test specimen and cut hole locations as shown in FSRG A-15-951A – dimensions in mm

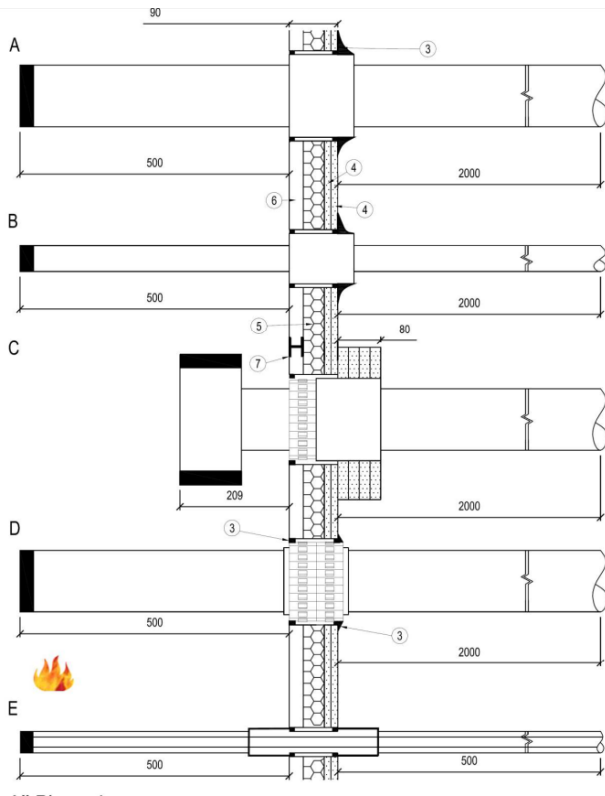
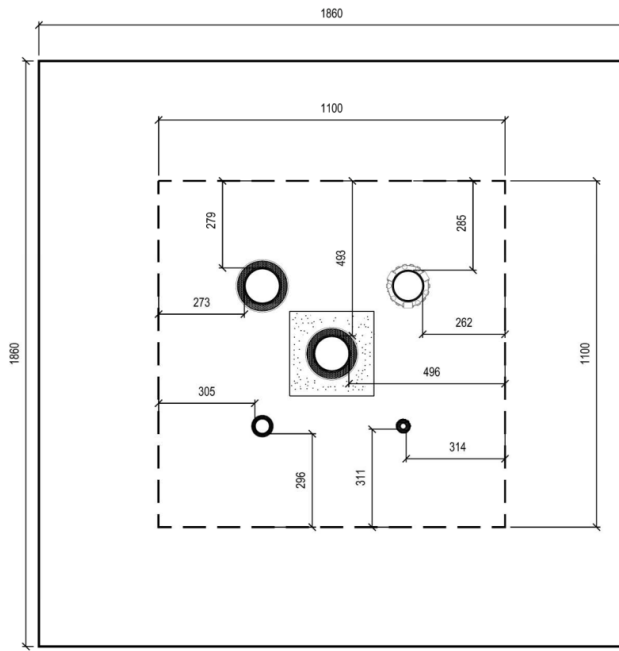
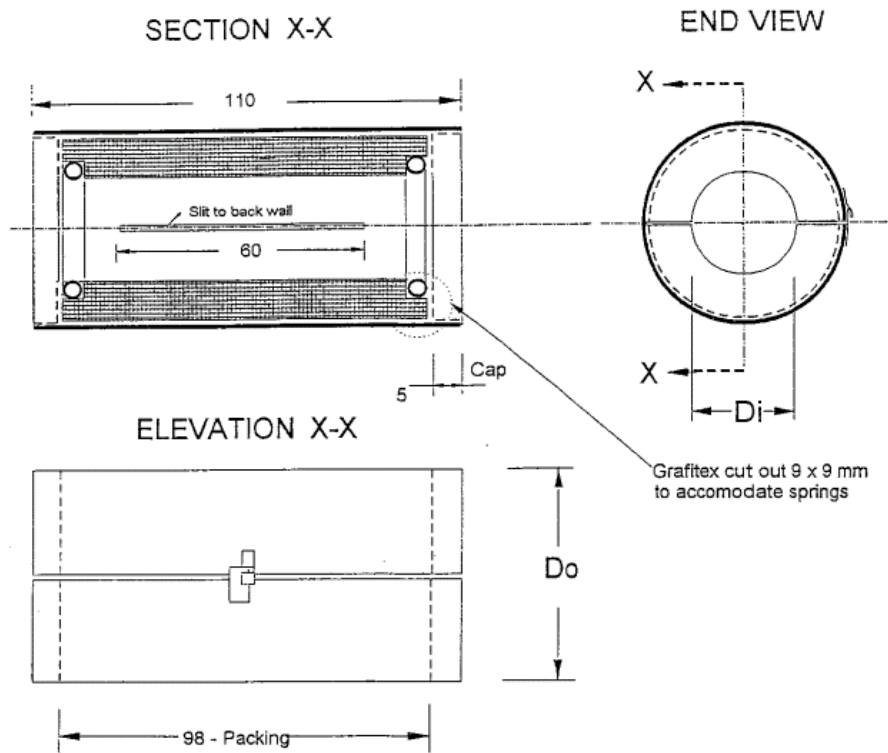

Figure 11 Plan view and cross sections of test specimen and cut hole locations as shown in FSRG A-15-951A – dimensions in mm



MATERIAL:

Body 0.8 mm Zincseal
End Caps 0.8 mm do. Perf Lockers No. P181

Springs fitted to sizes 150, 100 and 80 only

Springs from 0.036" (0.91mm) SS wire, Coil O.D 6.5 mm.
End loops full turn bent out 90 deg. parallel to body
Stretch formers from 3.2 mm dia PVC welding rod

CANISTER DIMENSIONS			
Size	Di	Do	Graf
40	45	70	12
50	58	84	12
65	71	97	12
80	85	110	18
100	113	150	18
150	163	200	18

Pipe Size	Body Length	Stretched length
150	270	540
100	190	380
80	145	290

Figure 12 Internally mounted Fyreguard wall collar details as shown in WFRA 91622 and WFRA 91633 – dimensions in mm

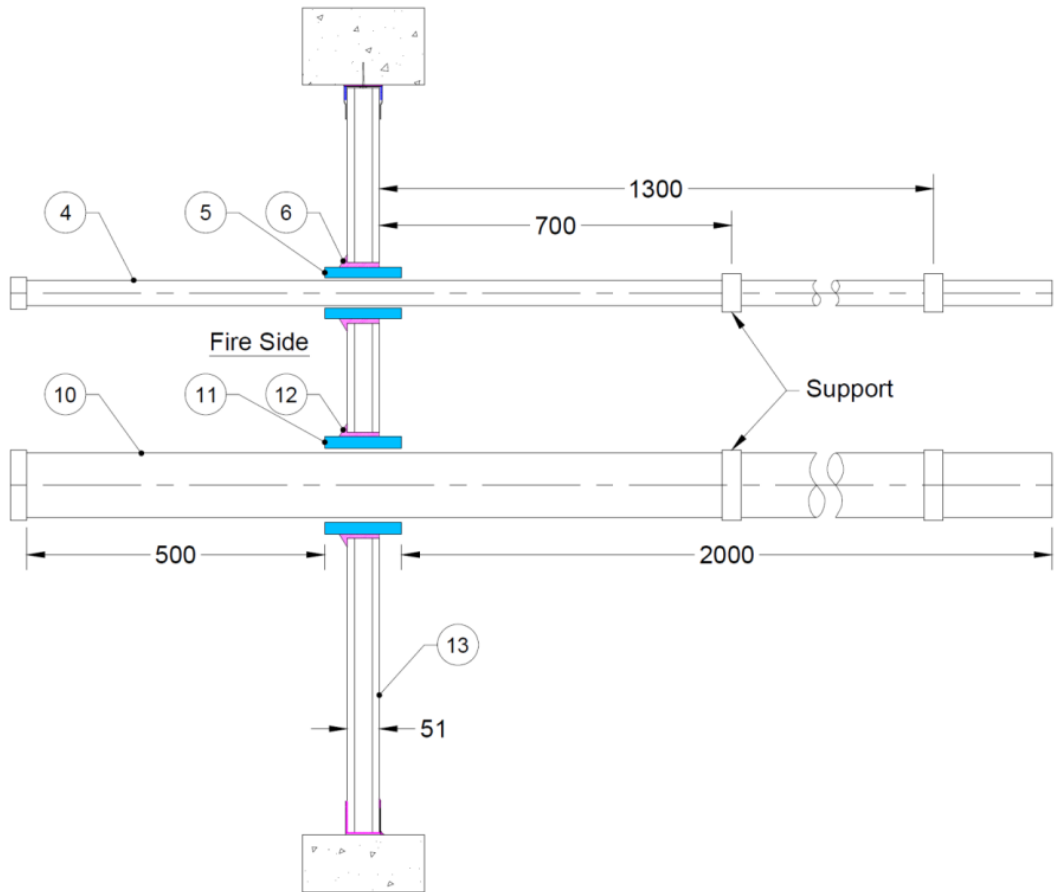

Figure 13 Plan view and cross sections of test specimen and cut hole locations as shown in EWFA2798800.1 – dimensions in mm

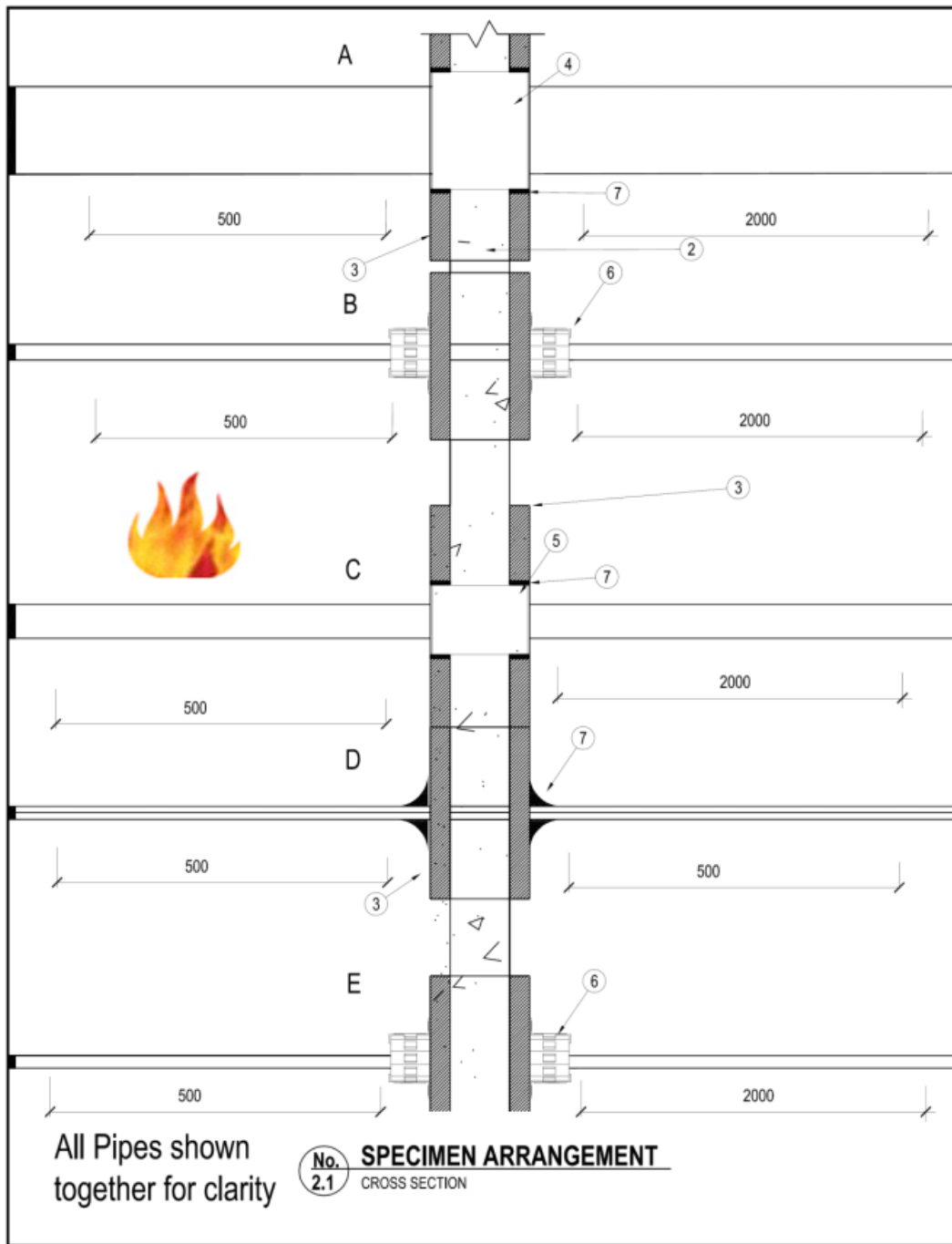

Figure 14 Plan view and cross sections of test specimen and cut hole locations as shown in FSRG A-12-775a – dimensions in mm

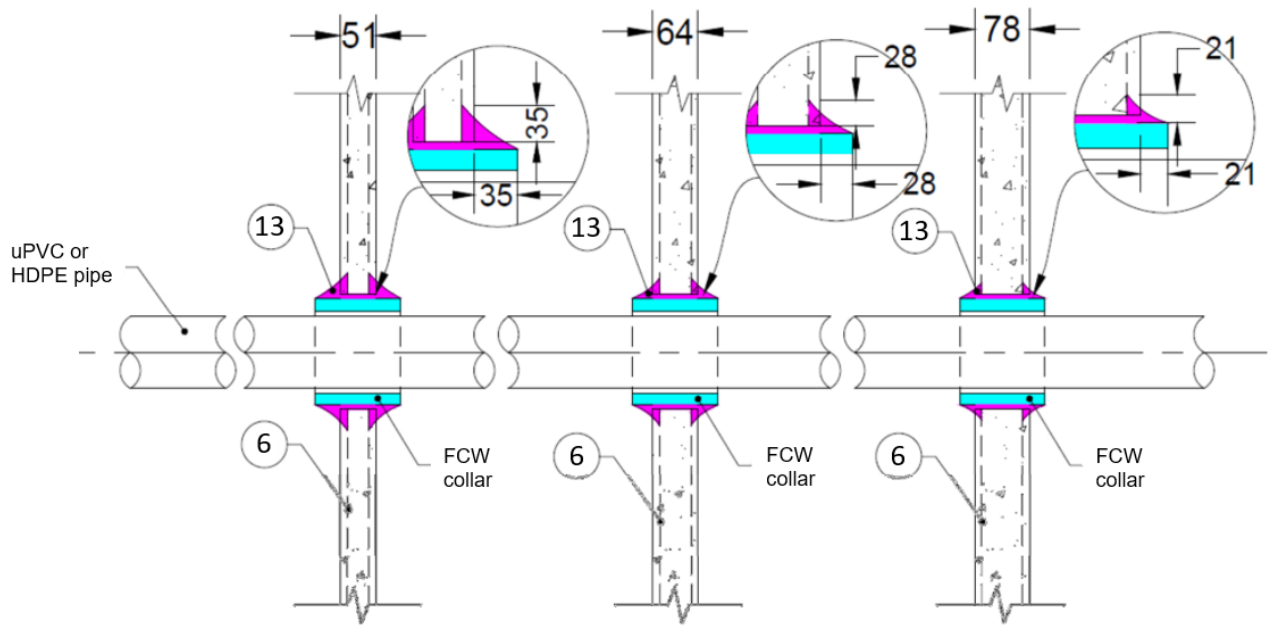

Figure 15 Proposed construction of uPVC and HDPE pipe protected with FCW collar in Speedpanel wall.

4. Scope, objectives and assumptions

4.1 Scope and objective

- The scope of this report is limited to an assessment of the variations to the tested systems described in section 3.
- We note that the established FRL of a non-loadbearing Hebel PowerPanel AAC wall is -/120/120. Some of the tested Hebel walls considered in this assessment report have shown better fire resistance performance than others, which is not warranted. To understand the actual fire resistance performance of the Hebel PowerPanel AAC walls please refer to any tests or assessments done by others on this separating element. The outcome of the assessment is not to be taken as having universal applicability to the Hebel PowerPanel AAC walls.
- This report details the methods of construction, test conditions and assessed results that would have been expected if the specific elements of construction described here had been tested in accordance with AS 1530.4:2014.
- This report is only valid for the assessed systems. Any changes with respect to size, construction details, loads, stresses, edge or end conditions, other than those identified in this report, may invalidate the findings of this assessment. If there are changes to the system, a reassessment will be needed to verify consistency with the assessment in this report.
- The data, methodologies, calculations and conclusions documented in this report specifically relate to the assessed system/s and must not be used for any other purpose.
- This report has been prepared based on information provided by others. Warringtonfire has not verified the accuracy and/or completeness of that information and will not be responsible for any errors or omissions that may be incorporated into this report as a result.

5. Assessment 1 – uPVC pipes protected by Promaseal FCW fire collars

5.1 Description of variations

The tested systems comprised uPVC pipe penetrations of various diameters through vertical separating elements protected by Promaseal FCW fire collars (i.e., Promaseal Wall Collar). This assessment was undertaken to:

- Assess the applicability of the results in accordance with AS 1530.4:2014 and AS 4072.1-2005.
- Assess the expected performance of Promaseal FCW fire collars protecting uPVC pipe penetrations in below separating elements:
 - Plasterboard partition wall with nominal thickness of 128 mm. The fire collars are to be identical to those described in tests WFRA F91622 and WFRA F91633 except the internal springs are to be removed from the 80 mm size fire collar.
 - AAC panels with a nominal thickness of 75 mm as tested in FSRG A-13-816, FSRG A-14-879A and FSRG A-15-1011.
 - Solid plasterboard partition wall with nominal thickness of 48 mm (including 3×16 mm layers) as tested in FSRG A-13-823A.
 - Shaftwall liner with overall thickness of 90 mm (1×25 mm shaftwall sheets and 2×13 mm fire rated plasterboard) as tested in FSRG A-13-819 and 96 mm (proposed).
 - Masonry and concrete with a thickness of not less than 128 mm.

5.2 Methodology

The approach and method of assessment used for this assessment is summarised in Table 8.

Table 8 Method of assessment

Assessment method	
Level of complexity	Intermediate assessment
Type of assessment	Qualitative and comparative

5.3 Assessment

5.3.1 Applicability of the tests in accordance with AS 1530.4:2014

The tests WFRA F91622 and WFRA F91633 were conducted in accordance with AS 1530.4:1990 and WFRA F91731.3 was conducted in accordance with AS 1530.4:1997. Comparison of the guidelines between these standards and AS 1530.4:2014 is provided in Appendix B and Appendix C within this report. As per the discussion presented in sections B.2.6 and C.2.8, the results are considered to be in accordance with AS 1530.4:2014.

Tests FSRG A-13-819, FSRG A-13-816, FSRG A-14-879A, FSRG A-15-1011, FSRG A-15-1038 and FSRG A-13-823A were conducted in accordance with AS 1530.4:2005. A comparison of the guidelines between this standard and AS 1530.4:2014 is provided in Appendix D within this report. As per the discussion presented in section D.2.5, the results are considered to be in accordance with AS 1530.4:2014.

5.3.2 Promaseal FCW Wall Collar protecting uPVC pipe penetrations

2 × 16 mm plasterboard partition wall system as the separating element

The performance of Promaseal FCW fire collars protecting a range of uPVC pipes (40 mm to 150 mm) penetrating a 128 mm plasterboard partition wall was established in tests WFRA F91622 and WFRA F91633 – refer to Table 5. The separating element comprised 2×16 mm Gyprock Fyrchek plasterboard faced to both sides of a 64 mm steel stud.

In addition, test WFRA F91731.3 comprised a steel stud plasterboard partition penetrated by a number of uPVC and HDPE pipes protected by a system comprising a steel cylinder with a wrap of intumescent material similar to the intumescent used in the collars. The wraps contained less intumescent than the equivalent wall collar but exhibited similar behaviour to the equivalent collar in tests WFRA F91622 and WFRA F91633 – refer to Table 5. The most significant variations were the premature insulation failures, which occurred in test WFRA F91731.3. This was attributed to the low insulation performance of the wall and the requirement to fit thermocouples on the seal surface, since the temperatures on the uPVC pipes were comparable for the tests on the wraps and collars.

It is therefore considered reasonable to use the data from test WFRA F91731 to assess the performance of Promaseal FCW wall collars. The springs that were provided with the tested fire collars had a diameter of 0.91mm. Therefore, it is considered that if a spring had not been provided in the 80 mm collar tested in WFRA F91622 (specimen C), an FRL of -/120/120 would have been attained by comparing the performance of the services in the two tests.

The failure of the collar protecting the 161 mm pipe (nominal DN 150 mm) in test F91633 (specimen D in the report) occurred after 118 minutes when a gap formed above the collar on the non-fire side and a section of plasterboard fell away from the fire exposed face around a different penetration, permitting a straight line of vision to the furnace. The clearance between the opening for 150 mm service and the central penetration in the test was nominally 80 mm.

Based on the observed performance during the test, it is considered that the proximity of the penetrations initiated the localised collapse of the partition facing on the fire exposed face. This in turn contributed to the failure under the criterion of integrity after 118 minutes of the test.

It is therefore concluded that if the 150 mm uPVC pipe penetration protected with a Promaseal FCW wall collar identified as service D in test WFRA F91633 had been tested as a single penetration, it is expected to achieve an FRL of -/120/120 in accordance with AS 1530.4:2014.

Vertical steel studs would be considered to provide adequate separation between adjacent penetrations because the plasterboard facings would be secured to the stud. It is considered that a clear vertical separation of 400 mm between openings for penetrations occurring in a section of wall bounded by the same studs would be sufficient to prevent significant weakening of the facings, which would prevent the mode of failure described in test WFRA F91633.

If penetrations occur within vertical distances of 400 mm, it is considered that if the cavity is back blocked with plasterboard for 200 mm around the opening or steel noggins are provided to which the facings are fixed, the 150 mm pipe system described as service D in test F91633 would be expected to achieve an FRL of -/120/120.

2 × 13 mm plasterboard partition wall system as the separating element

The fire-resistant properties of Promat FCW collars protecting 40 mm and 100 mm uPVC pipes were documented in FSRG A-13-819. The separating element consisted of a 25 mm thick Shaft wall liner fitted within a metal frame on the fire-exposed side and 2×13 mm thick layers of plasterboard on the unexposed side. The cavity between the Shaftwall and the plasterboard was filled with a layer of 75 mm thick R1.5 glasswool batts. No integrity failure was observed during the 162-minute test duration. Insulation failure was observed at approximately 140 minutes for both services, with a temperature rise of over 180 K being recorded on the separating element 25 mm away from the collar. The integrity and insulation performance of the fire collars was not compromised for the duration of the test.

Similar results are to be expected should the 25 mm thick shaftwall be replaced by 2×13 mm layers of plasterboard on the exposed face, provided the 2 × 13 mm systems have previously been tested or assessed to an FRL of -/120/120 in accordance with AS 1530.4:2014. uPVC pipes with intermediate diameters are also expected to perform similarly in the 2 × 13 mm system and are expected to achieve an FRL of -/120/120.

The 150 mm uPVC pipe was tested in WFRA F91633 and identified as service D. The separating element comprised 2 ×16 mm Gyprock Fyrchek plasterboard faced to both sides of a 64 mm steel stud. Whilst integrity failure was observed at 118 minutes, it was concluded in the discussion above that the service is expected to achieve an FRL of -/120/120 as a single penetration. Integrity failure in the test was caused as a result of the separating element being compromised and that no fissures, gaps, or flaming events were observed around the collars. In addition, no significant temperature rise was observed on the service for the duration of the test after the intumescent collar was activated. It is therefore expected that the system is expected to achieve an FRL of -/120/120 for a 2 × 13 mm plasterboard wall system which has previously been tested or assessed in accordance with AS 1530.4:2014.

It should be noted that the above FRLs are only applicable if no changes to perimeter details (e.g., the type and depth of sealants used in FSRG-A-13-819), and insulation are made.

Autoclaved aerated concrete (AAC) wall as the separating element

The performance of internally mounted Promaseal FCW fire collars protecting uPVC pipes penetrations of 40, 50, 65 and 100 mm was established in tests FSRG A-13-816, FSRG A-14-879A and FSRG A-15-1011 – refer to Table 5 for details. The vertical separating elements were two 75 mm Hebel power panel blocks, 1800×600 mm (FSRG A-13-816) and three 75 mm Hebel power panel blocks, 1800×600 mm (FSRG A-14-879A and FSRG A-15-1011) glued together with CSR Hebel adhesive. The density of the tested separating element was not referenced in the reports.

Extracts from the test FSRG A-13-816, FSRG A-14-879A and FSRG A-15-1011 data are given in Table 9. Review of the test report FSRG A-14-879A indicates that the Ø40 mm pipe has performed until 108 minutes, and the Ø100 mm pipe has performed until 112 minutes at which point failure of insulation criteria has occurred in the specimen. However, the test specimen continued to maintain integrity in accordance with AS 1530.4:2005 – and as per discussion in section 5.3.1 in accordance with AS 1530.4:2014 – until 187 minutes.

There are four thermocouples in proximity of the pipe penetration (systems C and E in the test report FSRG A-14-879A), with two on the separating element 25 mm from the pipe location, two on the fire collar and the sealant fillet. Results show that the thermocouple on the sealant fillet has failed insulation criteria for Ø40 mm pipe (thermocouple E3 at 108 minutes), with the rest performing until the end of the test. The fire collar thermocouple has failed insulation criteria for Ø100 mm pipe (thermocouple C4 at 112 minutes), with the rest performing until the end of the test. Results also show that the intumescent material in the fire collar for both systems has activated and closed off the pipe penetration. The sponsor has confirmed in email correspondence dated 30 January 2010 that the thermocouple located on the fire collar for Ø40 mm pipe (thermocouple E4) has detached during the test, which may be associated with decreasing temperatures recorded by the thermocouple approximately 110 minutes into the test.

Table 9 Fire resistance performance of Promaseal FCW fire collars protecting uPVC pipe penetrations as tested in FSRG A-13-816, FSRG A-14-879A and FSRG A-15-1011

Reference test	Nominal pipe diameter (mm)	AAC Hebel PowePanel wall system description	Wall thickness (mm)	Promaseal Fire collar	Local fire stopping system	FRL (min)
FSRG A-13-816	50	2×1800×600 panel glued together with CSR Hebel adhesive.	75	FCW 50	Promaseal AN Acrylic sealant on unexposed side	-/180/120
	100			FCW 100		-/180/120
FSRG A-14-879A	100			FCW 100		-/180/90
	40			FCW 40		-/180/90

Reference test	Nominal pipe diameter (mm)	AAC Hebel PowePanel wall system description	Wall thickness (mm)	Promaseal Fire collar	Local fire stopping system	FRL (min)
FSRG A-15-1011	65	3×1800×600 panel glued together with CSR Hebel adhesive		FCW 65	Promaseal IBS, Promaseal AN Acrylic sealant	-/180/180
						-/180/180
						-/180/180

Based on the above information, it is proposed that uPVC pipe penetrations of diameter Ø40 mm to Ø100 mm in 75 mm thick AAC Hebel PowerPanel wall panel separating element are expected to achieve FRL -/180/90.

Solid plasterboard partition wall as the separating element

The performance of internally mounted Promaseal FCW fire collars protecting two sets of 40 and 100 mm uPVC pipes penetrations was established in test FSRG A-13-823A. The separating element was 3×16mm layers of Fyrecheck fire rated plasterboard (1800×1200 mm) installed vertically and back to back into a metal frame. The fire collars in the considered systems were inserted centrally, protruding approximately 36 mm on either side of the wall element – systems D and F in FSRG A-13-823A – or protruding 72 mm on the exposed side and flush with the unexposed side – systems A and B in FSRG A-13-823A. Therefore, it can be assumed that the fire collars contain an identical length of intumescent material and are only different in their installation configuration. The annular gap between the fire collar and the wall was sealed with Promaseal AN Acrylic on the unexposed side. The pipes were supported in two locations at 300 mm and 1500 mm on the unexposed side. Extracts from the test FSRG A-14-823A data are given in Table 10.

Table 10 Fire resistance performance of Promaseal FCW fire collars protecting uPVC pipe penetrations as tested in FSRG A-13-823A

Reference test	Nominal pipe diameter (mm)	Thickness (mm)	Main fire stopping system	FRL (min)
FSRG A-13-823A	100	48	Promaseal FCW 100 fire collar installed flush with separating element on the unexposed side	-/-
	40		Promaseal FCW 40 fire collar installed flush with separating element on the unexposed side	-/120/60
	100		Internally mounted Promaseal FCW 100 fire collar	-/120/90
	40		Internally mounted Promaseal FCW 40 fire collar	-/120/120

Review of the test results indicates that Ø100 mm pipe protected with a fire collar flush with the unexposed side (system A in test FSRG A-13-823A) had an integrity failure at 10 minutes as the pipe had fallen out of the collar and sustained flaming occurred for more than 10 s. Test observations indicate that the intumescent material had activated on the unexposed side at 8 minutes. Test photos show that the supporting hoops were in place at the end of the testing.

Insulation failure occurred on the separating element for Ø40 mm pipe protected with a fire collar flush with the unexposed side (system B in) at 88 minutes while integrity performance was maintained until the end of the test. Test results also indicate that Ø100 mm pipe protected with a fire collar inserted centrally (system D in test FSRG A-13-823A) had an insulation failure at 111 on the separating element.

It is considered that systems with the fire collar flush with the unexposed side are more onerous than when they are inserted centrally, protruding equally on either side of the wall.

Based on the above information, it is therefore proposed that uPVC pipe penetrations of diameter Ø40 mm to Ø100 mm protected by Promaseal FCW fire collars through 48 mm thick solid fire rated plasterboard wall separating elements are expected to achieve FRL -/120/90 subject to the fire collar being installed centrally.

Shaftwall liner wall system as the separating element

The performance of Promaseal FCW fire collars protecting uPVC pipes penetrations of 40 mm and 100 mm was established in test FSRG A-13-819 – refer to Table 5 for details. The separating element consisted of 3x1800x600 mm sheets of shaftwall liner, each 25 mm thick, fitted within a metal frame. The unexposed side of the system was fitted with two layers of 13 mm fire rated plasterboard and the overall thickness of the tested specimen was 90 mm. The gaps between the fire collar and the shaftwall were sealed with Promaseal AN Acrylic. Extracts from the test FSRG A-13-819 data are given in Table 11. The fire collars were installed flush with the separating element on the exposed side. It is considered that the Promaseal FCW fire collars protecting uPVC pipes through shaftwall are expected to achieve FRL -/120/120 if installed as per the test.

Table 11 Fire resistance performance of Promaseal FCW fire collars protecting uPVC pipe penetrations as tested in FSRG A-13-819

Reference test	Nominal pipe diameter (mm)	Shaftwall system description	Overall thickness (mm)	Promaseal Fire collar	FRL (min)
FSRG A-13-819	100	3x1800x600 sheets of 25 mm thick shaftwall liners. The unexposed side of the system was fitted with two layers of 13 mm fire rated plasterboard.	90	Promaseal FCW 100 fire collar installed flush with separating element on the exposed side	-/120/120
	40			Promaseal FCW 40 fire collar installed flush with separating element on the exposed side	-/120/120

It is also proposed that the overall thickness of the shaftwall liner may be increased to 96 mm. Clause 3.9 in section 3 of AS 1530.4:2014 stipulates permissible variations to the tested specimen for vertical separating elements. It states that the results of the fire test are directly applicable to similar constructions where one or more of the following changes have been made, provided no individual component is removed or reduced:

- Increase in the length of a wall of identical construction if the specimen was tested
- with one vertical edge unrestrained.
- Increase in thickness of the wall.
- For framed walls —
 - increase in timber density,
 - increase in cross-sectional dimensions of the framing element(s),
 - increase in steel thickness up to a maximum of 2 mm,
 - decrease in sheet or panel sizes,
 - decrease in stud spacing, or
 - decrease in fixing centres of wall sheet materials.

It is therefore proposed that if the thickness of the separating element is increased to 96 mm, it is expected to achieve at least equivalent to the tested 90 mm shaftwall as described in section 3 of this report.

Masonry and concrete wall as the separating element

Fire resistance performance of Promaseal FCW fire collars protecting uPVC pipe penetrations through AAC Hebel PowerPanels were tested in FSRG A-13-816, FSRG A-14-879A and FSRG A-15-1011 and results was discussed in section 5.3.2. Concrete/masonry and AAC Hebel panels are both concrete based materials. It can be said that concrete and masonry have a higher thermal mass and density with an established FRL of -/120/120. It is therefore considered that solid masonry/concrete wall system is expected to achieve at least -/180/120 FRL subject to overall thickness being not less than 128 mm and the density being equal or greater than 550 kg/m³.

Speedpanel wall as the separating element

The ability of the Promaseal FCW collars to protect uPVC pipes and restore the original fire resistance levels of the separating element is well documented in the sections above. Pipes and corresponding collars of multiple diameters were tested in various separating elements, all of which maintained integrity and insulation for 120 minutes with no impending signs of failure.

Fire resistance of uPVC pipes with a nominal diameter of 40 mm and 100 mm protected with Promaseal FCW 40 and FCW 100 collars penetrating a 51 mm thick Speedpanel wall is documented in EWFA 2798800.1. The collars were centrally installed in the aperture and the annular gaps between the collar and the wall were sealed with Hilti CP606 mastic. The mastic was finished off with a 20 mm fillet on the unexposed side. Both services-maintained integrity for the 132-minute duration of the test without any signs of impending formation of cracks, fissures or gaps. However, the insulation performance of the services was compromised due to temperatures being measured on the collar on the unexposed side having exceeded the minimum temperature rise. The heating of the collars was due to the heat directly conducted from the fire-exposed side through the steel casing. During the test, it was noted that the part of the collar covered with the Hilti CP 606 mastic sealant had significantly lower recorded temperatures (approximately 70-80 °C) compared with the part of the collar not covered with mastic.

The proposed construction comprises Hilti CP 606 mastic filler on each side of the pipe penetrations, with the collars on both sides being fully covered by the mastic as illustrated in Figure 15. The benefit of the proposed construction is that the insulation performance can be predicted with reasonable accuracy, with temperatures being significantly lower than the failure criteria in AS 1530.4:2014, thereby restoring the original fire resistance level of the wall system.

The ability of the Promaseal FCW collars to protect 40 mm and 100 mm uPVC pipes penetrating a 78 mm thick Speedpanel wall is documented in A-12-775a and illustrated in Figure 14 (service A and C). A piece of 25 mm thick Promatect 100, 100 mm greater than the penetration, was fixed with 40 mm long stitching screws to the wall. The annular gap was filled with Promaseal SupaMastic on both sides of the wall, including the Promatect 100 board.

Both systems exhibited excellent fire-resistant properties, with integrity being maintained for at least 240 minutes and insulation for at least 180 minutes. The build-up of boards to further protect the services is expected to conduct less heat to the unexposed face of the wall compared to having the separating element by itself, thereby making it less onerous. As discussed above, the ability of the Promaseal FCW collars to protect uPVC pipes and restore the original fire resistance levels of the separating element is well documented in the preceding sections. It can therefore be concluded that the construction methodology used in A-12-775a can be used to protect uPVC pipes between 40 mm and 100 mm in diameter to restore the original fire resistance level of the wall system.

The Promaseal FCW collars in a 64 mm and 78 mm thick Speedpanel wall system are more shielded than those tested in EWFA2798800.1. Hence, the expected temperatures on the unexposed face of the uPVC pipes and the collars would be much lower than those tested in the 51 mm thick Speedpanel wall for at least 90 and 120 minutes, respectively.

5.3.3 Changes in intumescent composition

Promat Australia Pty Ltd has confirmed in writing that since the issue of the original formal assessment WFRA C91513 R1.0, there has been a minor variation in the Graftex intumescent material used in the collars but no other changes to the formulation, specification, design, or material of systems or components have been made. The intumescent material used in the current Promaseal FCW fire collars varies slightly from the original material due to the manufacturing process where off cuts of the Graftex sheets are dried, ground to granules and re-used.

The expected fire resistance performance of Promaseal fire collars incorporating the recycled constituent material has been the subject of another assessment report number WFRA 45676. The assessment concluded that the use of the recycled constituent material would not adversely affect the performance of Promaseal fire collars as the material composition is not altered in the recycling process. Therefore, at least equivalent fire resistance performance would be expected for the current Promaseal FCW wall collars incorporating the recycled constituent material in accordance with AS 1530.4:2014.

5.3.4 General applicability conditions

Use of wall collars in series configuration in separating elements of 146 mm thick and above

The depth of the wall collar inserted centrally in the 128 mm thick plasterboard partition wall in test WFRA F91633 was 110 mm, which was positively assessed for -/120/120 FRL in section 5.3.2. The fire collar was inset into the wall by 9-10 mm on each side. The Promaseal Wall Collars are currently provided with an increased canister depth (H) of 120 mm instead of the tested 110 mm, which includes increased packing (intumescent material). It is therefore considered that, as the fire collar is now 120 mm long, if it were positioned for the same distance, the thickness of the separating element could be increased to 146 mm. This is considered as maximum wall thickness that is permitted to accommodate a single wall collar. For wall thickness exceeding 146 mm, two wall collars may be used in line with the permissible variation as outlined in Figure 10.12.5.1 (b) of AS 1530.4:2014.

Services not perpendicular to the wall

As per clause 10.12.5.2 of AS 1530.4:2014, it is also permitted to have penetrations not perpendicular to the plane of the separating element, provided the fire-stopping system has similar exposure and dimensions to the tested prototype.

5.4 Conclusion

This assessment demonstrates that the assessed uPVC pipe penetrations protected by Promaseal FCW Wall Collars are expected to achieve the fire resistance performance shown in Table 12, in accordance with the AS 1530.4:2014 and AS 4072.1-2005. Fire collars are to be inserted centrally on plasterboard and concrete walls and flush with the shaftwall on the exposed side.

Table 12 Summary of Assessment 1 conclusions

Nominal pipe diameter (mm)	Nominal Pipe wall thickness (mm)	Wall system description	Separating element thickness (mm)	Promaseal fire collar type	FRL (min)
40	2.6	2x13 mm ^e or 2x16 mm layers of plasterboard faced to both sides of a 64 mm steel stud.	116 or 128	FCW 40	-/120/120
50	2.2-3.0			FCW 50	
65	2.9			FCW 65	
80	3.4			FCW 80 – omission of internal springs permitted	
100	3.4			FCW 100	
150	5.0			FCW 150	
40	2		75	FCW 40	-/180/90

Nominal pipe diameter (mm)	Nominal Pipe wall thickness (mm)	Wall system description	Separating element thickness (mm)	Promaseal fire collar type	FRL (min)
50	2.6	AAC Hebel PowerPanels glued together with CSR Hebel adhesive using a 6mm deep notched trowel.		FCW 50	
65	3.7			FCW 65	
80	3.4			FCW 80	
100	3.4-4			FCW 100	
40	2	Masonry and concrete with a density of at least 550 kg/m ³	128	FCW 40	-/180/120
50	2.6			FCW 50	
65	3.7			FCW 65	
80	3.4			FCW 80	
100	3.4-4			FCW 100	
40	3	Vertically oriented separating element with 3x16mm layers of Fyrecheck fire rated plasterboard (1800x1200 mm) installed vertically into a metal frame.	48	FCW 40	-/120/90
50	2.6			FCW 50	
65	3.7			FCW 65	
80	3.4			FCW 80	
100	3.6			FCW 100	
40	3	1x25 mm thick shaftwall liner with unexposed side fitted with 2x13 or 2x16 mm fire rated plasterboard.	90 or 96	FCW 40	-/180/120
50	2.6			FCW 50	
65	3.7			FCW 65	
80	3.4			FCW 80	
100	3.6			FCW 100	
40	3	Speedpanel ^f wall	51	FCW 40	-/60/60
50	2.6			FCW 50	
65	3.7			FCW 65	
80	3.4			FCW 80	
100	3.6			FCW 100	
40	3		64	FCW 40	-/90/90
50	2.6			FCW 50	
65	3.7			FCW 65	
80	3.4			FCW 80	
100	3.6			FCW 100	
40	3		78	FCW 40	-/120/120
50	2.6			FCW 50	
65	3.7			FCW 65	
80	3.4			FCW 80	
100	3.6			FCW 100	

^eThe cavity in the 2 x 13 mm plasterboard system must be insulated using 75 mm thick R1.5 glasswool insulation batts

Nominal pipe diameter (mm)	Nominal Pipe wall thickness (mm)	Wall system description	Separating element thickness (mm)	Promaseal fire collar type	FRL (min)
<p>†The Speedpanel wall must be installed in accordance with procedures listed in their test or assessment reports to achieve the desired fire resistance levels. Please contact Speedpanel to obtain the correct and latest version of the evidence. Refer to pre-requisites summarized in Section 5.3.2, and Figure 14 (Service A and C) and Figure 15 for further details on installation of local fire-stopping systems.</p>					

6. Assessment 2 – HDPE pipe penetrations protected by Promaseal FCW fire collars

6.1 Description of variation

The tested systems comprised uPVC pipe penetrations of various diameters through vertical separating elements protected by Promaseal FCW fire collars (i.e., Promaseal Wall Collar). This assessment was undertaken to:

- Assess the applicability of the results in accordance with AS 1530.4:2014 and AS 4072.1-2005.
- Assess the expected performance of Promaseal FCW fire collars protecting HDPE pipe penetrations in below separating elements:
 - Plasterboard partition wall with a nominal thickness of 128 mm. The fire collars are to be similar to those described in tests WFRA F91622 and WFRA F91633 except the collar diameters are adjusted to suite the pipe outside diameters, the internal springs are not fitted on any collar sizes and the intumescent thickness shall be 12 mm.
 - AAC with a nominal thickness of 75 mm as tested in FSRG A-15-1038 and FSRG A-15-1011.
 - Masonry and concrete with a thickness not less than 128mm.

6.2 Methodology

The approach and method of assessment used for this assessment is summarised in Table 8.

Table 13 Method of assessment

Assessment method	
Level of complexity	Intermediate assessment
Type of assessment	Qualitative and comparative

6.3 Assessment

6.3.1 Applicability of the tests in accordance with AS 1530.4:2014

The tests WFRA F91622 and WFRA F91633 were conducted in accordance with AS 1530.4:1990 and WFRA F91731.3 was conducted in accordance with AS 1530.4:1997. Comparison of the guidelines between these standards and AS 1530.4:2014 is provided in Appendix B and Appendix C within this report. As per the discussion presented in sections B.2.6 and C.2.8, the results are considered to be in accordance with AS 1530.4:2014.

The tests FSRG A-15-1011 and FSRG A-15-1038 were conducted in accordance with AS 1530.4:2005. A comparison of the guidelines between this standard and AS 1530.4:2014 is provided in Appendix D within this report. As per the discussion presented in section D.2.5, the results are considered to be in accordance with AS 1530.4:2014.

6.3.2 Promaseal FCW Wall Collar protecting HDPE pipe penetrations

2 × 13 mm and 2 × 16 mm plasterboard partition wall system as the separating element

The performance of Promaseal FCW fire collars protecting a range of uPVC pipes (40 mm to 150 mm) penetrating a 128 mm plasterboard partition wall was established in tests WFRA F91622 and WFRA F91633 – refer to Table 5. The separating element comprised 2×16 mm Gyprock Fyrchek plasterboard faced on both sides of a 64 mm steel stud.

The test WFRA F91731.3 comprised a steel stud plasterboard partition penetrated by a number of uPVC and HDPE pipes protected by a system comprising a steel cylinder with a wrap of intumescent material similar to the intumescent used in the collars. The wraps contained less intumescent than the

equivalent wall collar but exhibited similar behaviour to the equivalent collar in tests WFRA F91622 and WFRA F91633. The most significant variations were the premature insulation failures, which occurred in test WFRA F91731. These can be attributed to the low insulation performance of the wall and the requirement to fit thermocouples on the seal surface.

A comparison of the results for the HDPE and uPVC pipes protected with wraps in test WFRA F91731.3 showed a trend for the initial temperature peak to be higher for the uPVC pipes, indicating a greater safety margin for initial closure. All pipe penetration systems failed insulation on the wall surface between 45 and 64 minutes. The insulation level of the wall was nominally 60 minutes. The temperature rise limits on the penetrating pipes were not exceeded during the 122-minute test.

Although on a different separating element (75 mm Speedpanel), the ability of the FCW collars to protect 40 mm and 100 mm HDPE pipes was tested and reported in FSRG A-12-777. No cracks, fissures, or gaps were observed for the duration of the test, thereby demonstrating the ability of the intumescent to fully close and seal the gaps.

It is therefore considered that failure under the criterion of insulation and integrity would have been unlikely to have occurred if the HDPE pipes had been tested when protected with Promaseal FCW wall collars and mounted 2 x 13 mm or a 2 x 16 mm plasterboard wall system tested or assessed to -/120/120 in accordance with AS 1530.4:2014. This is subject to fire collar diameters being adjusted to suit the pipe outside diameters and intumescent thickness being set at 12 mm.

Autoclaved aerated concrete (AAC) wall as the separating element

The performance of Promaseal FCW fire collars protecting a range of HDPE pipes penetrations of 50 and 100 mm was established in tests FSRG A-15-1011 and FSRG A-15-1038 – refer to Table 5 for details. The vertical separating elements were 3x1800x600 Hebel power panel blocks of 75 mm thickness glued together with CSR Hebel adhesive. The density of the tested separating element was not referenced in the reports.

Extracts from the tests FSRG A-15-1011 and FSRG A-15-1038 data are given in Table 14. Review of the test report FSRG A-15-1038 indicates that the Ø100 mm pipe has performed until 118 minutes, at which point failure of insulation criteria has occurred on the sealant. The HDPE pipe wall thickness was 3.9 mm in FSRG A-15-1011 and 2.5 mm in FSRG A-15-1038. Furthermore, the test specimens continued to maintain integrity in accordance with AS 1530.4:2005 – and as per discussion in section 5.3.1 in accordance with AS 1530.4:2014 – until the end of the test.

Table 14 Fire resistance performance of Promaseal FCW fire collars protecting HDPE pipe penetrations as tested in FSRG A-15-1011 and FSRG A-15-1038

Reference test	Nominal pipe diameter (mm)	Nominal Pipe wall thickness (mm)	Wall system description	Wall thickness (mm)	Promaseal Fire collar	Local fire stopping system	FRL (min)
FSRG A-15-1011	100	3.9	2x1800x600 AAC Hebel panel glued together with CSR Hebel adhesive.	75	FCW 50	Promaseal IBS, Promaseal AN Acrylic sealant	-/180/180
	50	3.2			FCW 100		-/180/180
FSRG A-15-1038	100	2.5	3x1800x600 AAC Hebel panel glued together with CSR Hebel adhesive		FCW 100	Promaseal -A Acrylic sealant	-/180/90

Based on the above information, it is therefore proposed that HDPE pipe penetrations of diameter Ø40 mm to Ø100 mm in a 75 mm thick AAC Hebel PowerPanel wall panel separating element protected by Promaseal FCW Wall Collar are expected to achieve FRL -/180/120 subject to the Ø100 HDPE pipe having a wall thickness of not less than 3.9 mm.

Masonry and concrete wall as the separating element

Fire resistance performance of Promaseal FCW fire collars protecting HDPE pipe penetrations through AAC Hebel PowerPanels was tested in FSRG A-15-1011 and FSRG A-15-1038 and results were discussed in section 6.3.2 above. Concrete/masonry and AAC Hebel panels are both concrete based materials. It can be said that concrete and masonry have a higher thermal mass and density with an established FRL of -/120/120. It is therefore considered that solid masonry/concrete wall system is expected to achieve at least -/180/120 FRL subject to overall thickness being not less than 128 mm and the density being equal or greater than 550 kg/m³.

Speedpanel wall as the separating element

The ability of the Promaseal FCW collars to protect 40 mm and 100 mm HDPE pipes penetrating a 78 mm thick Speedpanel wall system is documented in FSRG A-12-777. Similar to what was done in FSRG A-12-775a for uPVC pipes, the service penetrations were additionally protected using a 25 mm thick Promatect 100 board. The annular gaps were filled using Promaseal SupaMastic on both sides. The test was stopped at 160 minutes with no failure recorded on either of the services.

No significant differences were observed in the temperature curves for tests done on uPVC versus those on HDPE pipes. The performance of the system is therefore expected to be controlled by the failure of the separating element and not the fire protection systems. The same could also be said should the services be installed in accordance with procedures used in EWFA 2798800.1.

6.4 Conclusion

This assessment demonstrates that the assessed HDPE pipe penetrations protected by Promaseal FCW Wall Collars are expected to achieve the fire resistance performance shown in Table 12, in accordance with the AS 1530.4:2014 and AS 4072.1-2005. Fire collars are to be inserted centrally into the separating element.

Table 15 Summary of Assessment 2 conclusions

Nominal pipe diameter (mm)	Nominal Pipe wall thickness (mm)	Wall system description	Separating element thickness (mm)	Promaseal fire collar type	FRL (min)
50	3.2	2x13 mm ⁹ or 2x16mm layers of plasterboard faced to both sides of a 64 mm steel stud.	116 or 128	FCW Wall Collars. Diameters to be adjusted to suite the pipe outside diameters and intumescent thickness to be 12 mm. Omission of internal springs is permitted.	-/120/120
63	3.2				
75	3.2				
90	3.8				
40	As manufactured	AAC Hebel PowerPanels glued together with CSR Hebel adhesive using a 6mm deep notched trowel.	75	FCW 40	-/180/120
50	3.2			FCW 50	
65	As manufactured			FCW 65	
80	As manufactured			FCW 80	
100	3.9			FCW 100	
40	As manufactured	Masonry and concrete with a density of at least 550 kg/m ³	128	FCW 40	-/180/120
50	3.2			FCW 50	
65	As manufactured			FCW 65	
80	As manufactured			FCW 80	
100	3.9			FCW 100	
40	As manufactured		51	FCW 40	-/60/60

50	3.2	Speedpanel ^h wall		FCW 50	
65	As manufactured			FCW 65	
80	As manufactured			FCW 80	
100	3.9			FCW 100	
40	As manufactured		64	FCW 40	-/90/90
50	3.2			FCW 50	
65	As manufactured			FCW 65	
80	As manufactured			FCW 80	
100	3.9			FCW 100	
40	As manufactured		78	FCW 40	-/120/120
50	3.2			FCW 50	
65	As manufactured			FCW 65	
80	As manufactured			FCW 80	
100	3.9			FCW 100	

^gThe cavity in the 2 × 13 mm plasterboard system must be insulated using 75 mm thick R1.5 glasswool insulation batts

^hThe Speedpanel wall must be installed in accordance with procedures listed in their test or assessment reports to achieve the desired fire resistance levels. Please contact Speedpanel to obtain the correct and latest version of the evidence. Refer to pre-requisites summarized in Section 6.3.2 and Figure 14 (Service A and C) and Figure 15 for further details on installation of local fire-stopping systems.

7. Validity

Warringtonfire Australia does not endorse the tested or assessed product in any way. The conclusions of this assessment may be used to directly assess fire hazard, but it should be recognised that a single test method will not provide a full assessment of fire hazard under all conditions.

Due to the nature of fire testing and the consequent difficulty in quantifying the uncertainty of measurement, it is not possible to provide a stated degree of accuracy. The inherent variability in test procedures, materials and methods of construction, and installation may lead to variations in performance between elements of similar construction.

This assessment is based on information and experience available at the time of preparation. The published procedures for the conduct of tests and the assessment of test results are subject to constant review and improvement. It is therefore recommended that this report be reviewed on or before, the stated expiry date.

This assessment represents our opinion about the performance expected to be demonstrated on a test in accordance with AS 1530.4:2014, based on the evidence referred to in this report.

This assessment is provided to the Promat Australia Pty Ltd for its own purposes and we cannot express an opinion on whether it will be accepted by building certifiers or any other third parties for any purpose.

Appendix A Summary of supporting test data

A.1 Test report – WFRA F91731.3

Table 16 Information about test report

Item	Information about test report
Report sponsor	Fyreguard Pty Ltd
Test laboratory	Warrington Fire Research (Aust) Pty Ltd, PO Box 867, Mulgrave, Victoria 3170
Test date	The fire resistance test was completed on 30/06/1998.
Test standards	The test was done in accordance with AS 1530.4:1997.
Variation to test standards	NA
General description of tested specimen	<p>The test assembly comprised four uPVC pipes, four HDPE pipes and one cable tray with cables penetrating a steel stud Promina partition. The Promina partition, of nominal dimension 3200 mm x 3200 mm, consisted of a 1 x 9 mm layer of Promat Fyreguard Promina board, screw fixed to each face of 50 mm steel studs, spaced at nominally 600 mm centres. Each stud was faced over the full length with an approximately 100 mm wide strip of 9 mm Promina board and backed with approximately 100 mm wide strips of 9 mm Promina board. The overall partition depth was approximately 90 mm.</p> <p>The service pipe penetrations in the Promina partition were each protected by a Promaseal pipe wrap, comprising one layer of intumescent material, housed in a nominal 0.8mm thick sheet metal sleeve extending approximately the full depth of the Promina partition. The gaps between the Promaseal pipe wrap and the Promina sheets were filled with Promaseal mastic. The gaps between the plastic pipes and the intumescent material were filled with a non-fire rated silicon sealant.</p> <p>For further information regarding the test specimens, refer to the test report WFRA F91731.3 dated 24 September 1998 prepared by Warrington Fire Research.</p>
Instrumentation	The test report states that the instrumentation was in accordance with AS 1530.4:1997.

The test was discontinued after a period of 122 minutes. The test specimen achieved the following result:

Table 17 Results summary for this test report

Penetration system reference	Nominal Pipe Diameter (mm)	Pipe Material	Criteria	Results	Fire resistance level (FRL)
1	50	uPVC	Structural adequacy	Not applicable	-/120/45
			Integrity	No failure at 122 minutes	
			Insulation	Failure at 50 minutes	
2	40	uPVC	Structural adequacy	Not applicable	-/120/45
			Integrity	No failure at 121 minutes	
			Insulation	Failure at 49 minutes	
3	65	uPVC	Structural adequacy	Not applicable	-/120/145
			Integrity	No failure at 121 minutes	

Penetration system reference	Nominal Pipe Diameter (mm)	Pipe Material	Criteria	Results	Fire resistance level (FRL)
			Insulation	Failure at 54 minutes	
4	50	HDPE	Structural adequacy	Not applicable	-/120/60
			Integrity	No failure at 121 minutes	
			Insulation	Failure at 60 minutes	
5	65	HDPE	Structural adequacy	Not applicable	-/120/60
			Integrity	No failure at 121 minutes	
			Insulation	Failure at 64 minutes	
6	80	uPVC	Structural adequacy	Not applicable	-/120/45
			Integrity	No failure at 122 minutes	
			Insulation	Failure at 53 minutes	
7	40	HDPE	Structural adequacy	Not applicable	-/120/45
			Integrity	No failure at 121 minutes	
			Insulation	Failure at 45 minutes	
8	80	HDPE	Structural adequacy	Not applicable	-/120/45
			Integrity	No failure at 121 minutes	
			Insulation	Failure at 58 minutes	
9	Cable tray – 300 mm wide		Structural adequacy	Not applicable	-/60/60
			Integrity	Failure at 80 minutes	
			Insulation	Failure at 62 minutes	

A.2 Test report – WFRA F91622

Table 18 Information about test report

Item	Information about test report
Report sponsor	Fyreguard Pty Ltd
Test laboratory	Warrington Fire Research (Aust) Pty Ltd, PO Box 867, Mulgrave, Victoria 3170
Test date	The fire resistance test was completed on 18/10/1995.
Test standards	The test was done in accordance with AS 1530.4:1990.
Variation to test standards	None reported
General description of tested specimen	A fire test has been performed in accordance with AS 1530.4:1990 sections 2, 3 and 10 as appropriate on a test assembly comprising various services penetrating a nominally 128mm thick plasterboard partition. The procedures of AS 4072.1-1992 were followed as appropriate. For further information regarding the test specimens, refer to the test report WFRA F91622 dated 22 December 1995 prepared by Warrington Fire Research.
Instrumentation	The test report states that the instrumentation was in accordance with AS 1530.4:1990.

The test was discontinued after a period of 121 minutes. The test specimen achieved the following result:

Table 19 Results summary for this test report

Penetration system reference	Service description	Criteria	Results	Fire resistance level (FRL)
A	43 mm O.D. SWV uPVC pipe protected with an internally mounted Fyreguard wall collar	Structural adequacy	Not applicable	-/120/120
		Integrity	No failure at 121 minutes	
		Insulation	No failure at 121 minutes	
B	69 mm O.D. SWV uPVC pipe protected with an internally mounted Fyreguard wall collar.	Structural adequacy	Not applicable	
		Integrity	No failure at 121 minutes	
		Insulation	No failure at 121 minutes	
C	83 mm O.D. SWV uPVC pipe protected with an internally mounted Fyreguard wall collar.	Structural adequacy	Not applicable	
		Integrity	No failure at 121 minutes	
		Insulation	No failure at 121 minutes	
E	25 mm O.D. uPVC electrical conduit protected with Grafitec paste applied to the full depth of the facings on both faces of the partition.	Structural adequacy	Not applicable	
		Integrity	No failure at 121 minutes	
		Insulation	No failure at 121 minutes	

A.3 Test report – WFRA F91633

Table 20 Information about test report

Item	Information about test report
Report sponsor	Fyreguard Pty Ltd
Test laboratory	Warrington Fire Research (Aust) Pty Ltd, PO Box 867, Mulgrave, Victoria 3170
Test date	The fire resistance test was completed on 04/12/1995.
Test standards	The test was done in accordance with AS 1530.4:1990.
Variation to test standards	NA
General description of tested specimen	A report describing a fire test performed in accordance with AS 1530.4:1990 section, 2, 3 and 10 as appropriate on a test assembly comprising various services penetrating a nominally 128mm thick plasterboard partition. The procedure of AS 4072.1-1992 was followed as appropriate. For further information regarding the test specimens, refer to the test report WFRA F91633 dated 11 April 1996 prepared by Warrington Fire Research.
Instrumentation	The test report states that the instrumentation was in accordance with AS 1530.4:1990.

The test was discontinued after a period of 121 minutes. The test specimen achieved the following result:

Table 21 Results summary for this test report

Penetration system reference	Service description	Criteria	Results	Fire resistance level (FRL)
A	110 mm O.D. uPVC sewer pipe protected with an internally mounted Fyreguard wall collar	Structural adequacy	Not applicable	-/120/120
		Integrity	No failure at 120 minutes	
		Insulation	No failure at 120 minutes	
B	19 mm O.D. copper pipe complete with 9.5m thick Aeroflex insulation protected with Grafitex paste.	Structural adequacy	Not applicable	-/120/120
		Integrity	No failure at 120 minutes	
		Insulation	No failure at 120 minutes	
C	56 mm O.D. SWV uPVC pipe protected with an internally mounted Fyreguard wall collar.	Structural adequacy	Not applicable	-/120/120
		Integrity	No failure at 120 minutes	
		Insulation	No failure at 120 minutes	
D	161 mm O.D. uPVC sewer pipe protected with an internally mounted Fyreguard wall collar	Structural adequacy	Not applicable	-/900/120
		Integrity	Failure at 118 minutes	
		Insulation	No failure at 120 minutes	

Penetration system reference	Service description	Criteria	Results	Fire resistance level (FRL)
	A cluster of two pipes, one being a 32 mm O.D. XPLE pipe and the other being a 19 mm O.D. copper pipe complete with 'Kernlag' green rubber insulation, both protected with Graitex paste applied to the full depth of the facings on both faces of the partition.	Structural adequacy	Not applicable	-/120/60
		Integrity	No failure at 120 minutes	
		Insulation	Failure at 82 minutes	

A.4 Test report – FSRG A-13-816

Table 22 Information about test report

Item	Information about test report
Report sponsor	Promat Australia Pty Ltd
Test laboratory	Fire Science Research Group (FSRG) – Adelaide division, 1 Scotland Road, Mile End South, SA 5031
Test date	The fire resistance test was completed on 21/03/2013.
Test standards	The test was done in accordance with AS 1530.4:2005.
Variation to test standards	None reported
General description of tested specimen	A report describing a fire test performed in accordance with AS 1530.4:2005 on a test assembly comprising various services pipes and cables protected by Promaseal CFC FCW type collars penetrating a nominally 75 mm thick Hebel wall. For further information regarding the test specimens, refer to the test report WFRA F9633 dated 10 May 2013 prepared by FSRG.
Instrumentation	The test report states that the instrumentation was in accordance with AS 1530.4:2005.

The test was discontinued after a period of 209 minutes. The test specimen achieved the following result:

Table 23 Results summary for this test report

Penetration system reference	Service description	Criteria	Results	Fire resistance level (FRL)
A	Promaseal FCW 50 protecting a 50 mm uPVC	Structural adequacy	Not applicable	-/180/120
		Integrity	No failure at 209 minutes	
		Insulation	Failure at 178 minutes	
B	A double Promaseal CFC 32 protecting a 20 mm PEX-a pipe	Structural adequacy	Not applicable	-/180/120
		Integrity	No failure at 209 minutes	
		Insulation	Failure at 164 minutes	
C	A double Promaseal CFC 32 protecting a 20 mm PEX-a pipe with 20 mm thick Promatec 40 on unexposed side	Structural adequacy	Not applicable	-/180/180
		Integrity	No failure at 209 minutes	
		Insulation	Failure at 181 minutes	
D	19 mm copper with 19.5 mm Armaflex, protected with Promaseal FlexiWrap and sealed with AN on fire side only	Structural adequacy	Not applicable	-/180/120
		Integrity	No failure at 209 minutes	
		Insulation	Failure at 141 minutes	

Penetration system reference	Service description	Criteria	Results	Fire resistance level (FRL)
E	40 mm diameter penetration filled with a bunch of 12 Molex CAT 7 network cables protected with Promaseal AN Acrylic Sealant on both sides	Structural adequacy	Not applicable	-/180/180
		Integrity	No failure at 209 minutes	
		Insulation	Failure at 208 minutes	
F	Promaseal FCW 100 protecting a 100 mm uPVC pipe	Structural adequacy	Not applicable	-/180/120
		Integrity	No failure at 209 minutes	
		Insulation	Failure at 136 minutes	
G	A double Promaseal CFC 32 protecting a 25 mm PEX-a pipe	Structural adequacy	Not applicable	-/180/90
		Integrity	No failure at 209 minutes	
		Insulation	Failure at 98 minutes	
H	A double Promaseal CFC 32 protecting a 25 mm PEX-a pipe with 20 mm thick Promatec 40 on unexposed side	Structural adequacy	Not applicable	-/180/180
		Integrity	No failure at 209 minutes	
		Insulation	Failure at 197 minutes	

A.5 Test report – FSRG A-13-819

Table 24 Information about test report

Item	Information about test report
Report sponsor	Promat Australia Pty Ltd
Test laboratory	Fire Science Research Group (FSRG) – Adelaide division, 1 Scotland Road, Mile End South, SA 5031
Test date	The fire resistance test was completed on 28/02/2013.
Test standards	The test was done in accordance with AS 1530.4:2005.
Variation to test standards	None reported
General description of tested specimen	A report describing a fire test performed in accordance with AS 1530.4:2005 on a test assembly comprising uPVC pipes protected by Promaseal FCW and Promastop UniCollar penetrating a shaftwall nominally 90 mm thick. For further information regarding the test specimens, refer to the test report WFRA F9633 dated 28 November 2013 prepared by FSRG.
Instrumentation	The test report states that the instrumentation was in accordance with AS 1530.4:2005.

The test was discontinued after a period of 162 minutes. The test specimen achieved the following result:

Table 25 Results summary for this test report

Penetration system reference	Service description	Criteria	Results	Fire resistance level (FRL)
A	Promaseal FCW 100 protecting a 100 mm uPVC pipe	Structural adequacy	Not applicable	-/120/120
		Integrity	No failure at 162 minutes	
		Insulation	Failure at 142 minutes	
B	Promaseal FCW 40 protecting a 40 mm uPVC pipe	Structural adequacy	Not applicable	-/120/120
		Integrity	No failure at 162 minutes	
		Insulation	Failure at 143 minutes	
C	Promaseal FCW 100 and UniCollar protecting a 100 mm uPVC pipe with a 90 degree junction	Structural adequacy	Not applicable	-/120/120
		Integrity	No failure at 162 minutes	
		Insulation	No failure at 162 minutes	
D	Promaseal UniCollars protecting a 100 mm uPVC pipe with a coupling	Structural adequacy	Not applicable	-/-/-
		Integrity	Failure at 7 minutes	
		Insulation	Failure at 7 minutes	

Penetration system reference	Service description	Criteria	Results	Fire resistance level (FRL)
E	Promaseal Flexwrap protecting a 19 mm copper pipe with 19 mm thick Armaflex	Structural adequacy	Not applicable	-/120/90
		Integrity	No failure at 162 minutes	
		Insulation	Failure at 115 minutes	

A.6 Test report – FSRG A-13-823A

Table 26 Information about test report

Item	Information about test report
Report sponsor	Promat Australia Pty Ltd
Test laboratory	Fire Science Research Group (FSRG) – Adelaide division, 1 Scotland Road, Mile End South, SA 5031
Test date	The fire resistance test was completed on 28/05/2013.
Test standards	The test was done in accordance with AS 1530.4:2005.
Variation to test standards	None reported
General description of tested specimen	A report describing a fire test performed in accordance with AS 1530.4:2005 on a test assembly comprising uPVC and REHAU pipes protected by Promaseal FCW and CFC 32 collars penetrating a 48 mm thick fire-rated solid plasterboard partition wall. For further information regarding the test specimens, refer to the test report WFRA F9633 dated 6 June 2013 prepared by FSRG.
Instrumentation	The test report states that the instrumentation was in accordance with AS 1530.4:2005.

The test was discontinued after a period of 123 minutes. The test specimen achieved the following result:

Table 27 Results summary for this test report

Penetration system reference	Service description	Criteria	Results	Fire resistance level (FRL)
A	Promaseal FCW 100 flush with unexposed side protecting a 100 mm uPVC pipe	Structural adequacy	Not applicable	-/-/-
		Integrity	Failure at 10 minutes	
		Insulation	Failure at 10 minutes	
B	Promaseal FCW 40 flush with the unexposed side protecting a 40 mm uPVC pipe	Structural adequacy	Not applicable	-/120/60
		Integrity	No failure at 123 minutes	
		Insulation	Failure at 88 minutes	
C	Single Promaseal CFC 32 collar protecting a 20 mm PEX-a pipe	Structural adequacy	Not applicable	-/90/90
		Integrity	Failure at 119 minutes	
		Insulation	No failure at 96 minutes	
D	Promaseal FCW 100 centrally mounted protecting a 100 mm uPVC pipe	Structural adequacy	Not applicable	-/120/90
		Integrity	No failure at 123 minutes	
		Insulation	Failure at 111 minutes	

Penetration system reference	Service description	Criteria	Results	Fire resistance level (FRL)
E	Single Promaseal CFC 32 collar protecting a 20 mm PE-AL-PEX pipe	Structural adequacy	Not applicable	-/90/-
		Integrity	Failure at 118 minutes	
		Insulation	Failure at 29 minutes	
F	Promaseal FCW 40 centrally mounted protecting a 40 mm uPVC pipe	Structural adequacy	Not applicable	-/120/120
		Integrity	No failure at 123 minutes	
		Insulation	No failure at 123 minutes	

A.7 Test report – FSRG A-14-879A

Table 28 Information about test report

Item	Information about test report
Report sponsor	Promat Australia Pty Ltd
Test laboratory	Fire Science Research Group (FSRG) – Adelaide division, 1 Scotland Road, Mile End South, SA 5031
Test date	The fire resistance test was completed on 12/06/2014.
Test standards	The test was done in accordance with AS 1530.4:2005
Variation to test standards	None reported
General description of tested specimen	A report describing a fire test performed in accordance with AS 1530.4:2005 on a test assembly comprising various pipe penetrations through a 75 mm thick Hebel PowerPanel. For further information regarding the test specimens refer to the test report WFRA F9633 dated 7 September 2014 prepared by FSRG.
Instrumentation	The test report states that the instrumentation was in accordance with AS 1530.4:2005.

The test was discontinued after a period of 187 minutes. The test specimen achieved the following result:

Table 29 Results summary for this test report

Penetration system reference	Service description	Criteria	Results	Fire resistance level (FRL)
A	Promaseal CFC 32 protecting a 16 mm Gas Plus HDPE/AL/PEX pipe	Structural adequacy	Not applicable	-/180/120
		Integrity	No failure at 187 minutes	
		Insulation	Failure at 172 minutes	
B	Promastop UniCollar protecting a 110 mm uPVC pipe	Structural adequacy	Not applicable	-/180/120
		Integrity	No failure at 187 minutes	
		Insulation	Failure at 149 minutes	
C	Promaseal FCW 100 protecting a 110 mm uPVC pipe	Structural adequacy	Not applicable	-/180/90
		Integrity	No failure at 187 minutes	
		Insulation	No failure at 112 minutes	
D	Promaseal FC 40 protecting a 40 mm uPVC pipe	Structural adequacy	Not applicable	-/180/120
		Integrity	No failure at 187 minutes	
		Insulation	No failure at 167 minutes	

Penetration system reference	Service description	Criteria	Results	Fire resistance level (FRL)
E	Promaseal FCW 40 protecting a 40 mm uPVC pipe	Structural adequacy	Not applicable	-/180/90
		Integrity	No failure at 187 minutes	
		Insulation	Failure at 108 minutes	
F	Promaseal FCW 100 protecting a 110 mm uPVC pipe	Structural adequacy	Not applicable	-/180/180
		Integrity	No failure at 187 minutes	
		Insulation	No failure at 187minutes	
G	Promaseal CFC 32 protecting a 16 mm PEX Plus PE-Xa pipe	Structural adequacy	Not applicable	-/180/120
		Integrity	No failure at 187 minutes	
		Insulation	Failure at 178 minutes	
H	Promaseal CFC 32 protecting a 32 mm REHAU PE-Xa pipe	Structural adequacy	Not applicable	-/180/180
		Integrity	No failure at 187 minutes	
		Insulation	Failure at 183 minutes	

A.8 Test report – FSRG A-15-1011A

Table 30 Information about test report

Item	Information about test report
Report sponsor	Promat Australia Pty Ltd
Test laboratory	Fire Science Research Group (FSRG) – Adelaide division, 1 Scotland Road, Mile End South, SA 5031
Test date	The fire resistance test was completed on 21/09/2015.
Test standards	The test was done in accordance with AS 1530.4:2005
Variation to test standards	None reported
General description of tested specimen	A report describing a fire test performed in accordance with AS 1530.4:2005 on a test assembly comprising various pipe penetrations through a 75 mm thick Hebel PowerPanel. For further information regarding the test specimens, refer to the test report WFRA F9633 dated 7 May 2019 prepared by FSRG.
Instrumentation	The test report states that the instrumentation was in accordance with AS 1530.4:2005.

The test was discontinued after a period of 183 minutes. The test specimen achieved the following result:

Table 31 Results summary for this test report

Penetration system reference	Service description	Criteria	Results	Fire resistance level (FRL)
A	Promaseal FCW 100 protecting a 100 mm HDPE pipe	Structural adequacy	Not applicable	-/180/180
		Integrity	No failure at 183 minutes	
		Insulation	No failure at 183 minutes	
B	Promaseal FCW 65 protecting a 65 mm uPVC pipe	Structural adequacy	Not applicable	-/180/180
		Integrity	No failure at 183 minutes	
		Insulation	No failure at 183 minutes	
C	Promaseal FCW 50 protecting a 50 mm HDPE pipe	Structural adequacy	Not applicable	-/180/180
		Integrity	No failure at 183 minutes	
		Insulation	No failure at 183 minutes	
D	Promaseal FCW 100 protecting a 100 mm HDPE pipe	Structural adequacy	Not applicable	-/180/120
		Integrity	No failure at 183 minutes	
		Insulation	Failure at 162 minutes	

Penetration system reference	Service description	Criteria	Results	Fire resistance level (FRL)
E	P23 Telstra electrical conduit protected by double Promaseal CFC 32	Structural adequacy	Not applicable	-/180/180
		Integrity	No failure at 183 minutes	
		Insulation	No failure at 183 minutes	

A.9 Test report – FSRG A-15-1038

Table 32 Information about test report

Item	Information about test report
Report sponsor	Promat Australia Pty Ltd
Test laboratory	Fire Science Research Group (FSRG) – Adelaide division, 1 Scotland Road, Mile End South, SA 5031
Test date	The fire resistance test was completed on 21/01/2015.
Test standards	The test was done in accordance with AS 1530.4:2005
Variation to test standards	None reported
General description of tested specimen	A report describing a fire test performed in accordance with AS 1530.4:2005 on a test assembly comprising various pipe penetrations through a 75 mm thick Hebel PowerPanel. For further information regarding the test specimens, refer to the test report WFRA F9633 dated 13 July 2016 prepared by FSRG.
Instrumentation	The test report states that the instrumentation was in accordance with AS 1530.4:2005

The test was discontinued after a period of 180 minutes. The test specimen achieved the following result:

Table 33 Results summary for this test report

Penetration system reference	Service description	Criteria	Results	Fire resistance level (FRL)
B	A 32 mm PEX/AL/PEX pipe protected by double Promaseal CFC 32	Structural adequacy	Not applicable	-/180/60
		Integrity	No failure at 180 minutes	
		Insulation	Failure at 74 minutes	
C	Promastop FCW 100 protecting a 100 mm uPVC pipe	Structural adequacy	Not applicable	-/180/90
		Integrity	No failure at 180 minutes	
		Insulation	Failure at 118 minutes	
E	A 25 mm PEX/AL/PEX pipe protected by double Promaseal CFC 32	Structural adequacy	Not applicable	-/180/60
		Integrity	No failure at 180 minutes	
		Insulation	Failure at 87 minutes	

A.10 Test report – FSRG A-12-775a

Table 34 Information about test report

Item	Information about test report
Report sponsor	Promat Australia Pty Ltd
Test laboratory	Fire Science Research Group (FSRG) – Adelaide division, 1 Scotland Road, Mile End South, SA 5031
Test date	The fire resistance test was completed on 16 August 2012
Test standards	The test was done in accordance with AS 1530.4:2005
Variation to test standards	None reported
General description of tested specimen	Fire test using Promaseal CFC 32, Promaseal FCW and Promaseal SupaMastic protecting various types of pipes and cables within a 75 mm thick Speedpanel partition.
Instrumentation	The test report states that the instrumentation was in accordance with AS 1530.4:2005.

The test was discontinued after a period of 241minutes. The test specimen achieved the following result:

Table 35 Relevant results summary for this test report

Penetration system reference	Service description	Criteria	Results	Fire resistance level (FRL)
A	Promaseal FCW 100 protecting a 100 mm uPVC pipe	Structural adequacy	Not applicable	-/240/180
		Integrity	No failure at 241 minutes	
		Insulation	Failure at 193 minutes	
C	Promaseal FCW 40 protecting a 40 mm uPVC pipe	Structural adequacy	Not applicable	-/240/180
		Integrity	No failure at 241 minutes	
		Insulation	Failure at 182 minutes	

A.11 Test report – FSRG A-12-777

Table 36 Information about test report

Item	Information about test report
Report sponsor	Promat Australia Pty Ltd
Test laboratory	Fire Science Research Group (FSRG) – Adelaide division, 1 Scotland Road, Mile End South, SA 5031
Test date	The fire resistance test was completed on 30/08/2012.
Test standards	The test was done in accordance with AS 1530.4:2005.
Variation to test standards	NA
General description of tested specimen	Fire testing using Promaseal CFC 32, Promaseal FCW collars and Promaseal SupaMastic protecting various types of pipes and cables within a 75 mm thick Speedpanel partition.
Instrumentation	The test report states that the instrumentation was in accordance with AS 1530.4:2005.

The test was discontinued after a period of 160 minutes. The test specimen achieved the following result:

Table 37 Relevant results summary for this test report

Penetration system reference	Service description	Criteria	Results	Fire resistance level (FRL)
D	Promaseal FCW 100 protecting a 100 mm HDPE pipe	Structural adequacy	Not applicable	-/120/120
		Integrity	No failure at 160 minutes	
		Insulation	No failure at 160 minutes	
F	Promaseal FCW 40 protecting a 40 mm HDPE pipe	Structural adequacy	Not applicable	-/120/120
		Integrity	No failure at 160 minutes	
		Insulation	No failure at 160 minutes	

A.12 Test report – WFRA 2798800.1

Table 38 Information about test report

Item	Information about test report
Report sponsor	Speedpanel (VIC) Pty. Ltd.
Test laboratory	Exova Warringtonfire Pty Ltd, 409-411 Hammond Road, Dandenong South, VIC 3175
Test date	The fire resistance test was completed on 29 January 2013
Test standards	The test was done in accordance with AS 1530.4:2005.
Variation to test standards	None reported
General description of tested specimen	A report describing a fire test performed on a 51 mm thick Speedpanel wall system, that was penetrated by various services. The services were protected using Promaseal FCW collars and Hilti CP 606 Mastic.
Instrumentation	The test report states that the instrumentation was in accordance with AS 1530.4:2005.

The test was discontinued after a period of 132 minutes. The test specimen achieved the following result:

Table 39 Relevant results summary for this test report

Penetration system reference	Service description	Criteria	Results	Fire resistance level (FRL)
B	Promaseal FCW 40 protecting a 40 mm PVC pipe	Structural adequacy	Not applicable	-/120/-
		Integrity	No failure at 132 minutes	
		Insulation	Failure at 28 minutes	
D	Promaseal FCW 100 protecting a 100 mm uPVC pipe	Structural adequacy	Not applicable	-/120/-
		Integrity	No failure at 162 minutes	
		Insulation	Failure at 27 minutes	

Appendix B Relevance of AS 1530.4:1990 test data with respect to AS 1530.4:2014

B.1 General

The referenced fire resistance tests WFRA F91622 and WFRA F91633 were conducted in accordance with AS 1530.4:1990, which differs slightly from AS 1530.4:2014. These variations and their potential effects on the fire resistance performance of the referenced test specimens are discussed below.

B.2 Discussion

B.2.1 Furnace temperature regime

The furnace heating regime in fire resistance tests, conducted in accordance with AS 1530.4:2014, follows a similar trend to that in AS 1530.4:1990. The specified specimen heating rate in AS 1530.4:1990 is given by:

$$T_t - T_0 = 345 \log(8t + 1)$$

AS 1530.4:2014 specifies furnace temperature to follow the following trend:

$$T_{AS1530.4-2014} = 345 \log_{10}(8t + 1) + 20$$

Where:

T_t = furnace temperature at time t , in degrees Celsius.

T_0 = initial furnace temperature, in degrees Celsius.

t = the time into the test, measured in minutes from the ignition of the furnace.

The heating regimes in AS 1530.4:1990 and AS 1530.4:2014 vary, in that the former is an expression of the temperature rise in the furnace above an initial ambient temperature and the latter (although similar) assumes that the initial furnace temperature (T_0) is 20°C irrespective of the actual ambient temperature. A test conducted in accordance with AS 1530.4:1990 on a warm day – ambient temperature above 20°C – could therefore be slightly more onerous than that conducted in accordance with AS 1530.4:2014.

The parameters outlining the control accuracy of the furnace temperature in AS 1530.4:2014 and AS 1530.4:1990 are not appreciably different.

Also, the furnace thermocouples used in the test F91633 were the same thermocouples specified in AS 1530.4:2014, but they were located inside a steel tube, not exposed by 25 mm as specified in AS 1530.4:2014. The shielding of the furnace thermocouples in test F914633 would result in the test specimen being exposed to a more severe heating regime when compared with that in a fire resistance test using exposed type furnace thermocouples due to the relatively slower response of the shielded thermocouples.

B.2.2 Furnace pressure

AS 1530.4:2014 requires a minimum pressure differential of 8 Pa above the laboratory atmosphere for both vertical and horizontal specimens.

AS 1530.4:2014 requires a minimum pressure differential of 15Pa ± 3Pa above the laboratory atmosphere at the centre of the lowest penetration for vertical specimens, and 20Pa ± 3Pa at 100 mm below the soffit for horizontal specimens.

The increase in furnace overpressure is only expected to be significant if cracks or fissures have developed in the test specimen.

The furnace pressure at the centre line of the 150 mm uPVC SWV pipe in test F91633 was calculated to be approximately 10.5 Pa. This reduction from the minimum 15Pa required by AS 1530.4:2014 would not be expected to significantly influence the performance of the sealing system, as the pipe appeared to have closed after approximately 12 minutes before failure was imminent and remained closed for the duration of the test.

B.2.3 Performance criteria

AS 1530.4:2014 specifies the following performance criteria for building materials and structures:

- structural adequacy (not relevant)
- integrity
- insulation

B.2.4 Integrity

The specimen shall be deemed to have failed regarding the service penetrations, in accordance with AS 1530.4:2014, if the specimen:

- collapses.
- sustains flaming on the non-fire side in excess of 10 seconds.
- ignites a cotton pad within 30 seconds when applied.

The integrity criterion varies slightly between AS 1530.4:1990 and AS 1530.4:2014. The specimen is deemed to have failed in accordance with AS 1530.4:1990 if the specimen:

- collapses.
- develops cracks, fissures or other openings through which flames or hot gases can pass.
- sustained flaming on the non-fire side in excess of 10 seconds.

The integrity criterion in accordance with AS 1530.4:1990 is generally more stringent. Integrity failure would normally occur prior to failure in accordance with AS 1530.4:2014.

B.2.5 Insulation

The insulation criteria of AS 1530.4:1990 and AS 1530.4:2014 remain the same, although the location of thermocouples has been revised. These differences are not considered relevant to the performance of the proposed construction.

B.2.6 Application of the test data to AS 1530.4:2014

In general, the furnace exposure conditions of AS 1530.4:1990 are not appreciably different to AS 1530.4:2014.

The difference in specified furnace pressures between the revisions of AS 1530.4 (1990 to 2014) is only expected to be significant if cracks or fissures have developed in the test specimen, as higher furnace overpressure has a greater tendency to force hot gases from the furnace to the non-fire side, with potentially adverse effects on both integrity and insulation performance.

Based on the above discussion, it is considered that that integrity performance of the tests WFRA F91622 and WFRA F91633 can be used to assess the insulation and integrity performance of the proposed construction if subjected to a fire resistance test in accordance with AS 1530.4:2014.

Appendix C Relevance of AS 1530.4:1997 test data with respect to AS 1530.4:2014

C.1 General

The referenced fire resistance test WFRA F91731.3 was conducted in accordance with AS 1530.4:1997, which differs slightly from AS 1530.4:2014. These variations and their potential effects on the fire resistance performance of the referenced test specimens are discussed below.

C.2 Discussion

C.2.1 Furnace temperature measurement

The specification for furnace thermocouples in AS 1530.4:2014 and AS 1530.4:1997 is not appreciably different.

C.2.2 Furnace temperature regime

AS 1530.4:2014 specifies furnace temperature to follow the following trend:

$$T_{AS153.04-2014} = 345 \log_{10}(8 + 1) + 20$$

AS 1530.4:1997 specifies furnace temperature to follow the following trend:

$$T_{AS1530.4-1997} = 345 \log_{10}(8t + 1) + T_0, 10^\circ\text{C} \leq T_0 \leq 40^\circ\text{C}$$

The parameters outlining the accuracy of control of the furnace temperature in AS 1530.4:2014 and AS 1530.4:1997 are not appreciably different.

C.2.3 Furnace pressure regime

AS 1530.4:2014 specifies that a pressure of $20 \pm 3\text{Pa}$ shall be maintained in the horizontal plane, 100 mm below the underside of the slab. The performance of the smaller pipe sizes was further verified under higher pressure conditions in test F91731.

Test report WFRA F91731.3 confirms that the pressure condition adhered to that prescribed by AS 1530.4:2014.

C.2.4 Specimen temperature measurement

AS 1530.4:2014 specifies specimen thermocouples as Type K, MIMS thermocouples with a stainless-steel sheaf, having a wire diameter not exceeding 0.5 mm and an overall diameter of 3 mm. The thermocouples shall be supported by a heat-resisting tube with the measuring junction protruding a minimum of 25 mm. Each thermocouple shall have the tail of its measuring junction soldered to the centre of a 12 mm diameter \times 0.2 mm thick copper disc. The disc shall be covered by $30 \pm 0.5\text{ mm} \times 30 \pm 0.5\text{ mm} \times 2.0 \pm 0.5\text{ mm}$ thick inorganic insulating pad with a density of $900 \pm 100\text{kg/m}^3$.

AS 1530.4:1997 specifies specimen thermocouples as Type K, MIMS thermocouples with a stainless-steel sheaf, having a wire diameter not exceeding 0.5 mm and an overall diameter of 3 mm. The thermocouples shall be supported by a heat-resisting tube with the measuring junction protruding a minimum of 25 mm. Each thermocouple shall have the tail of its measuring junction soldered to the centre of a 12 mm diameter \times 0.2 mm thick copper disc. The disc shall be covered by an oven-dry pad, no less than 30 mm square, made from material of a value $\sqrt{(k\rho c)}$ not greater than 600 at 150°C , and of such thickness as to give a thermal resistance ($R = t/K$) of $0.015\text{ K/W} - 0.025\text{ K/W}$ at 150°C .

For control joints installed in horizontal separating elements, AS 1530.4:2014 requires thermocouples to be located as follows:

- At least three on the surface of the seal, with one thermocouple for each 0.3m^2 of surface area, up to a maximum of five uniformly distributed over the area (one thermocouple being located at the centre of the seal).

- On the surface of the seal, 25 mm from the edge of the opening, with one thermocouple from each 500 mm of the perimeter.
- Thermocouples used for the evaluation of the insulation performance of control joints shall be positioned on the unexposed face of the sealing system and the separating element, except where the unexposed face of the seal is recessed within the separating element. Where this occurs, thermocouples shall only be fitted to the seal when the joint width is greater than or equal to 12 mm. Under these circumstances, the size of the pad may be reduced to facilitate the fitting of the thermocouple.

AS 4072.1-1992 requires thermocouples used for the evaluation of the insulation performance of control joints shall be positioned on the unexposed face of the sealing system and adjacent separating element, except where the unexposed face of the seal is within the separating element. Where this occurs, thermocouples shall only be fitted to the seal when the joint width is greater than the distance of the seal from the non-fire side of the specimen.

Based on the above discussion, it is considered that the insulation performance of specimens tested in WFRA F91731.3 can be used to assess the performance in accordance with AS 1530.4:2014.

C.2.5 Performance criteria

AS 1530.4:2014 specifies the following performance criteria for building materials and structures:

- structural adequacy (not relevant)
- integrity
- insulation

C.2.6 Integrity

AS 1530.4:2014 deems integrity failure to have occurred upon collapse, sustained (10 second) flaming, ignition of an applied cotton pad, or if a 6 mm gap gauge can protrude into the furnace and can be moved 150 mm along the gap, or if a 25 mm gap gauge can protrude into the furnace.

AS 1530.4:1997 deems integrity failure to occur upon collapse, the development of cracks, fissures, or other openings through which flames or hot gases can pass.

There were no observations made for the pipe penetrations relevant to this assessment in WFRA F91731.3 which were considered likely to have warranted the application of a cotton pad.

C.2.7 Insulation

The insulation criteria specified in AS 1530.4:2014 are the same as those specified in AS 1530.4:1997.

C.2.8 Application of the test data to AS 1530.4:2014

The minor variations in furnace heating regimes and specimen thermocouple specifications are not considered likely to significantly affect the behaviour of the specimens relevant to this assessment.

Based on the above, it is considered that the integrity and insulation behaviour of the specimens tested in WFRA F91731.3 can be used to assess the expected performance in accordance with AS 1530.4:2014.

Appendix D Relevance of AS 1530.4:2005 test data with respect to AS 1530.4:2014

D.1 General

The fire resistance tests FSRG A-13-819, FSRG A-13-816, FSRG A-14-879A, FSRG A-15-1011, and FSRG A-15-1038 and FSRG A-13-823A were in accordance with AS 1530.4:2005, which differs from AS 1530.4:2014. The effect these differences have on the fire resistance performance of the referenced test specimens is discussed below.

D.2 Discussion

The furnace heating regime in fire resistance tests conducted in accordance with AS 1530.4:2014 follows a similar trend to that of AS 1530.4:2005.

The specified specimen heating rate in AS 1530.4:2005 is given by:

$$T_t - T_0 = 365 \log(8t + 1) + 20$$

Where:

T_t = furnace temperature at time t , in degrees Celsius.

T_0 = initial furnace temperature, in degrees Celsius.

t = the time into the test, measured in minutes from the ignition of the furnace.

The parameters outlining the accuracy of control of the furnace temperature in AS 1530.4:2014 and AS 1530.4:2005 are not appreciably different.

D.2.1 Furnace pressure

The furnace pressure conditions for single and multiple penetration sealing systems in AS 1530.4:2005 and AS 1530.4:2014 are not appreciably different.

The parameters outlining the accuracy of control of the furnace pressure in AS 1530.4:2014 and AS 1530.4:2005 are not appreciably different.

D.2.2 Performance criteria

AS 1530.4:2014 specifies the following performance criteria for building materials and structures:

- structural adequacy (not relevant)
- integrity
- insulation

D.2.3 Integrity

AS 1530.4:2014 stipulates, in addition to the 20 mm thick × 100 mm × 100 mm cotton pads, additional cotton pads shall be provided with a reduced 30 mm × 30 mm × 20 mm with an additional wire frame holder and shall be used to determine integrity failure.

Apart from the above variation, the failure criteria for integrity in AS 1530.4:2014 and AS 1530.4:2005 are not appreciably different.

D.2.4 Insulation

The positions of thermocouples and failure criteria for insulation in AS 1530.4:2014 and AS 1530.4:2005 are not appreciably different.

D.2.5 Application of the test data to AS 1530.4:2014

Based on the above discussion and in the absence of any foreseeable integrity and insulation risk, it is concluded that the results relating to the integrity and insulation performance of the specimen – tested in FSRG A-13-819, FSRG A-13-816, FSRG A-14-879A, FSRG A-15-1011 and FSRG A-15-1038, FSRG A-13-823A – can be used to assess the integrity and insulation performance in accordance with AS 1530.4:2014.